

# TROPICAL MINI VRF SYSTEM



---

TRUST AIR CONDITIONING EQUIPMENT CO.  
Prepared By: Engineering & R & D Department.

# INSTALLATION MANUAL

*DC INVERTER FREE*

PRECAUTIONS.....	1
ATTACHED FITTINGS.....	2
OUTDOOR UNIT INSTALLATION.....	3
INSTALL THE CONNECTING PIPE.....	4
ELECTRICAL WIRING.....	9
TEST RUNNING.....	11
PRECAUTIONS ON REFRIGERANT LEAKAGE.....	11
TURN OVER TO CUSTOMER.....	11

## 1. PRECAUTIONS

- Ensure that all Local, National and International regulations are satisfied.
- Read this "PRECAUTIONS" carefully before Installation. The precautions described below include the important items regarding safety. Observe them without fail. After the installation work, perform a trial operation to check for any problem. Follow the Owner's Manual to explain how to use and maintain the unit to the customer. Turn off the main power supply switch (or breaker) before maintenance the unit.
- Ask the customer that the Installation Manual and the Owner's Manual should be kept together.



### CAUTION

New Refrigerant Air Conditioner Installation

**THIS AIR CONDITIONER ADOPTS THE NEW HFC REFRIGERANT(R410A)WHICH DOES NOT DESTROY OZONE LAYER.**

The characteristics of R410A refrigerant are; Hydrophilic, oxidizing membrane or oil, and its pressure is approx.1.6 times higher than that of refrigerant R22. Accompanied with the new refrigerant, refrigerating oil has also been changed. Therefore, during installation work, be sure that water, dust, former refrigerant, or refrigerating oil does not enter the refrigerating cycle.

To prevent charging an incorrect refrigerant and refrigerating oil, the sizes of connecting sections of charging port of the main unit and installation tools are changed from those for the conventional refrigerant.

Accordingly the exclusive tools are required for the new refrigerant (R410A):

For connecting pipes, use new and clean piping designed for R410A, and please care so that water or dust does not enter. Moreover, do not use the existing piping because there are problems with pressure-resistance force and impurity in it.



### CAUTION

Do not connect the Appliance from Main Power Supply.

This unit must be connected to the main power supply by means of a switch with a contact separation of at least 3 mm. The installation fuse must be used for the power supply line of this conditioner.



### WARNING

If the supply cord is damaged, it must be replaced by the manufacturer or its service agent or a similarly qualified person in order to avoid a hazard.

An all-pole disconnection switch having a contact separation of at least 3mm in all poles should be connected in fixed wiring. The appliance shall be installed in accordance with national wiring regulations.

The temperature of refrigerant circuit will be high, please keep the interconnection cable away from the copper tube.

An all-pole disconnection device which has at least 3mm separation distance in all pole and a residual current device(RCD) with the rating of above 10mA shall be incorporated in the fixed wiring according to the national rule.

The power cord type designation is H05RN-R/H07RN-F or above. Ask an authorized dealer or qualified installation professional to install/maintain the air conditioner.

Inappropriate installation may result in water leakage, electric shock or fire.

**Turn off the main power supply switch or breaker before attempting any electrical work.**

Make sure all power switches are off. Failure to do so may cause electric shock.

**Connect the connecting cable correctly.**

If the connecting cable is connected in a wrong way, electric parts may be damaged.

**When moving the air conditioner for the installation into another place, be very careful not to enter any gaseous matter other than the specified refrigerant into the refrigeration cycle.**

If air or any other gas is mixed in refrigerant, the gas pressure in the refrigeration cycle becomes abnormally high and it may resultingly causes pipe burst and injuries on persons.

**Do not modify this unit by removing any of the safety guards or by by-passing any of the safety interlock switches.**

**Exposure of unit to water or other moisture before installation may cause a short-circuit of electrical parts.**

Do not store it in a wet basement or expose to rain or water.

**After unpacking the unit, examine it carefully if there are possible damage.**

**Do not install in a place that might increase the vibration of the unit.**

**To avoid personal injury (with sharp edges), be careful when handling parts.**

**Perform installation work properly according to the Installation Manual.**

Inappropriate installation may result in water leakage, electric shock or fire.

**When the air conditioner is installed in a small room, provide appropriate measures to ensure that the concentration of refrigerant leakage occur in the room does not exceed the critical level.**

**Install the air conditioner securely in a location where the base can sustain the weight adequately.**

**Perform the specified installation work to guard against an earthquake.**

If the air conditioner is not installed appropriately, accidents may occur due to the falling unit.

**If refrigerant gas has leaked during the installation work, ventilate the room immediately.**

If the leaked refrigerant gas comes in contact with fire, noxious gas may generate.

**After the installation work, confirm that refrigerant gas does not leak.**

If refrigerant gas leaks into the room and flows near a fire source, such as a cooking range, noxious gas might generate.

**Electrical work must be performed by a qualified electrician in accordance with the Installation Manual. Make sure the air conditioner uses an exclusive power supply.**

An insufficient power supply capacity or inappropriate installation may cause fire.

**Use the specified cables for wiring connect the terminals securely fix. To prevent external forces applied to the terminals from affecting the terminals.**

**Be sure to provide grounding.**

Do not connect ground wires to gas pipes, water pipes, lightning rods or ground wires for telephone cables.

**Conform to the regulations of the local electric company when wiring the power supply.**

Inappropriate grounding may cause electric shock.

**Do not install the air conditioner in a location subject to a risk of exposure to a combustible gas.**

If a combustible gas leaks, and stays around the unit, a fire may occur.





**Required tools for installation work**

- 1) Philips screw driver
- 2) Hole core drill(65mm)
- 3) Spanner
- 4) Pipe cutter
- 5) Knife

- 6) Reamer
- 7) Gas leak detector
- 8) Tape measure
- 9) Thermometer
- 10) Mega-tester
- 11) Electro circuit tester
- 12) Hexagonal wrench
- 13) Flare tool
- 14) Pipe bender
- 15) Level vial
- 16) Metal saw
- 17) Gauge manifold (Charge hose:R410A special requirement)
- 18) Vacuum pump (Charge hose:R410A special requirement)
- 19) Torque wrench
  - 1/4(17mm)16N•m (1.6kgf•m)
  - 3/8(22mm)42N•m (4.2kgf•m)
  - 1/2(26mm)55N•m (5.5kgf•m)
  - 5/8(15.9mm)120N•m (12.0kgf•m)
- 20) Copper pipe gauge adjusting projection margin
- 21) Vacuum pump adapter

## 2. ATTACHED FITTINGS

Please check whether the following fittings are of full scope. If there are some spare fittings , please restore them carefully.

NAME	SHAPE	QUANTITY
1. Outdoor unit installation manual		1
2. Outdoor unit owner's manual		1
3. Indoor unit owner's manual		1
4.Outflow connecting tube		1

**Refrigerant Piping**

Piping kit used for the conventional refrigerant cannot be used.

Use copper pipe with 0.8 mm or more thickness for φ9.5.

Use copper pipe with 1.0 mm or more thickness for φ15.9.

Use copper pipe with 1.0 mm or more thickness for φ19.0.

Flare nut and flare works are also different form those of the conventional refrigerant.take out the flare nut attached to the main unit of the air conditioner, and use it.

**Before installation**

Be careful to the following items before installation.

**Air purge**

For air purge, use a vacuum pump.

Do not use refrigerant charged in the outdoor unit for air purge.

(The refrigerant for air purge is not contained in the outdoor unit.)

**Electrical cabling**

Be sure to fix the power cables and indoor/outdoor connecting cables with clamps so that they do not contact with the cabinet, etc.

**Installation Place**

A place which provides a specified space around the outdoor unit.

A place were the operation noise and discharged air are not given to your neighbors.

A place that is not exposed to a strong wind.

A place that does not block a passage.

When the outdoor unit is installed in an elevated position, make sure it's four feet securely installed.

There must be sufficient space for carrying in the unit.

A place where the drain water does not make any problem.

- When installing the outdoor unit in a place that is constantly exposed to a strong wind such as the upper stairs or rooftop of a building, apply the windproof measures referring to the following examples.
- Install the unit so that its discharge port faces to the wall of the building. Keep a distance 2000mm or more between the unit and the wall surface.

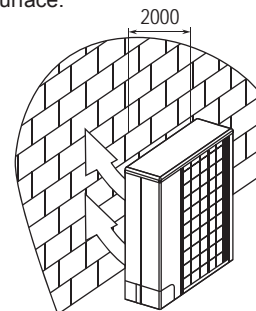

Fig.2-1

- Supposing the wind direction during the operation season of the discharge port is set at right angle to the wind direction.

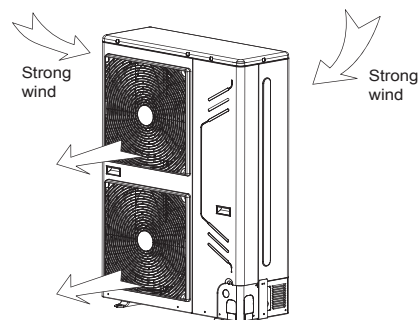

Fig.2-2

### CAUTION

- Install the outdoor unit at a place where discharge air is not blocked.
- When an outdoor unit is installed in a place that is always exposed to a strong wind like a coast or on a high storey of a building, secure a normal fan operation by using a duct or a wind shield.

- Installation in the following places may result in some troubles. Do not install the unit in such places below.
  - A place full of machine oil.
  - A place full of sulphuric gas.
  - A place where high-frequency radio waves are likely to be generated as from audio equipment, welders, and medical equipment.

### 3. OUTDOOR UNIT INSTALLATION

#### 3.1 Installation place

Please keep away from the following place, or malfunction of the machine may be caused:

- There is combustible gas leakage.
- There is much oil (including engine oil) ingredient.
- There is salty air surrounding (near the coast)
- There is caustic gas (the sulfide, for example) existing in the air (near a hot spring)
- A place the heat air expelled out from the outdoor unit can reach your neighbor's window.
- A place that the noise interferes your neighbors every day life.
- A place that is too weak to bear the weight of the unit
- Uneven place.
- Insufficient ventilation place.
- Near a private power station or high Frequency equipment.
- Install indoor unit, outdoor unit, power cord and connecting wire at least 1m away from TV set or radio to prevent noise or picture interference.
- Don't install it in a place whose air contains much salt. If this can't be avoided, choose an anticorrosive model.

The insulation of the metal parts of the building and the air conditioner should comply with the regulation of National Electric Standard.



#### CAUTION

Keep indoor unit, outdoor unit, power supply wiring and transmission wiring at least 1 meter away from televisions and radios. This is to prevent image interference and noise in those electrical appliances. (Noise may be generated depending on the conditions under which the electric wave is generated, even if 1 meter is kept.)

#### 3.2 Installation space (Unit:mm)

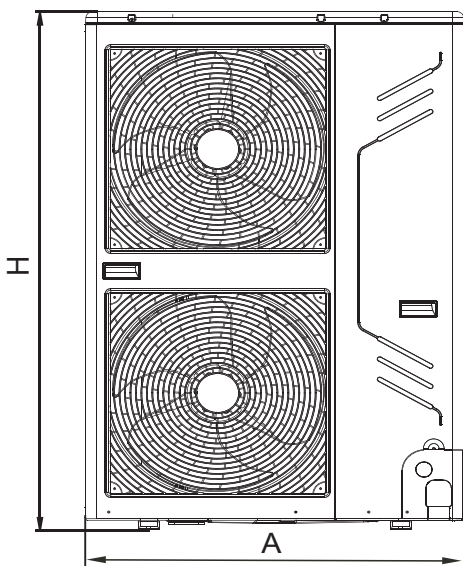

Fig.3-1

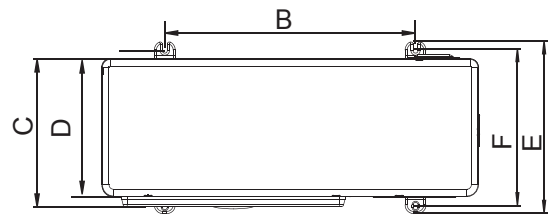

Fig.3-2

table 3-1

(unit: mm)

MODEL (kW)	A	B	C	D	E	F	G	H	Fig
10.5/14	900	600	348	320	400	360	—	1327	Fig.3-1 Fig.3-2

- Single unit installation

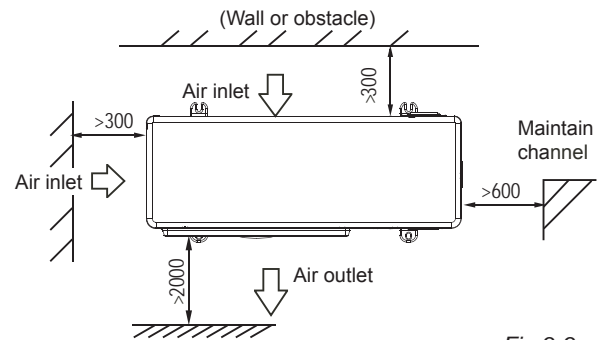

Fig.3-3

- Parallel connect the two units or above

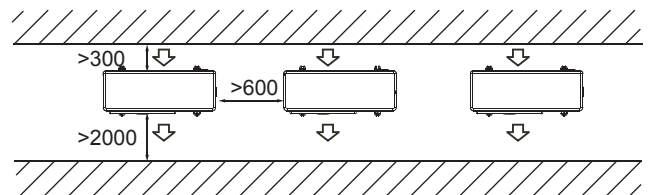

Fig.3-4

- Parallel connect the front with rear sides

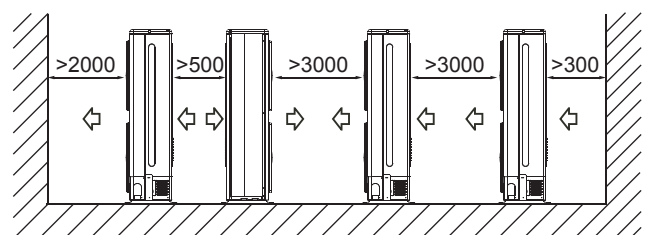

Fig.3-5

#### 3.3 Moving and installation

- Since the gravity center of the unit is not at its physical center, so please be careful when lifting it with a sling.
- Never hold the inlet of the outdoor unit to prevent it from deforming.
- Do not touch the fan with hands or other objects.
- Do not lean it more than 45°, and do not lay it sidelong.
- Make concrete foundation according to the specifications of the outdoor units. (refer to Fig.3-6)
- Fasten the feet of this unit with bolts firmly to prevent it from collapsing in case of earthquake or strong wind. (refer to Fig.3-6)

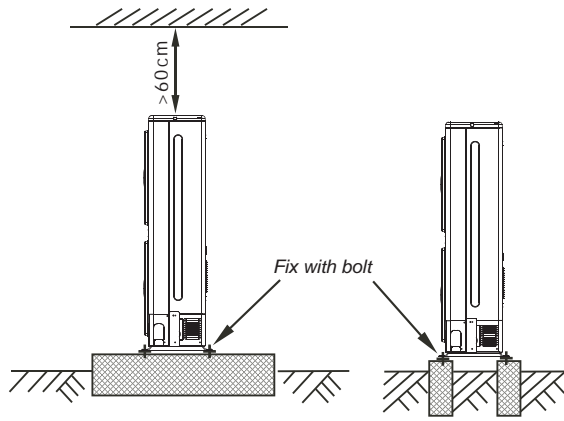

Fig.3-6

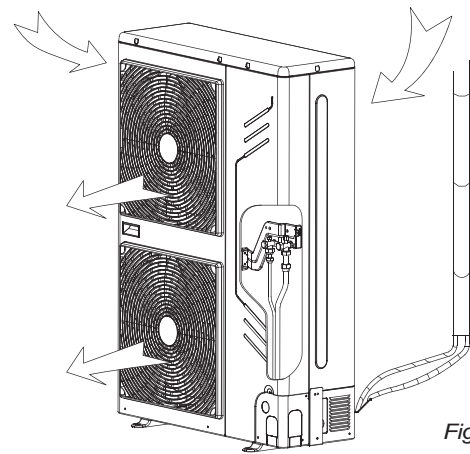

Fig.4-1



## NOTE

All the pictures in this manual are for explanation purpose only. They may be slightly different from the air conditioner you purchased (depend on model). The actual shape shall prevail.

## 3.4 Water Outlet

Four condensed water outlets on the chassis for selection display as the follow figure:

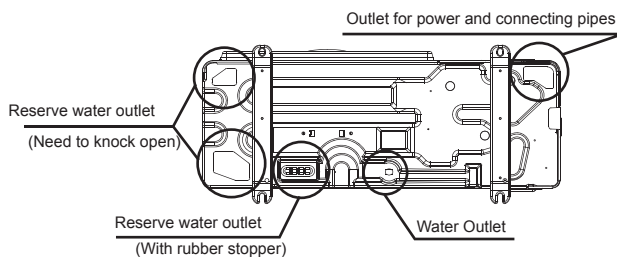

Fig.3-7



## CAUTION

While installing the outdoor unit, pay attention to the installation place and the drainage pattern; if it's installed at the alpine zone, the frozen condensed water will block up the water outlet, please pull out the rubber stopper of the reserve water outlet. If that still fails to satisfy for the water draining, please knock open the other two water outlets, and keep the water can drain in time. Pay attention to the knock the reserve water outlet from outside to inside, and it will be beyond repair after knocking open, please pay attention to the installation place, lest cause the inconvenience. Please do the moth proofing for the knocked out hole, to avoid the pest processing into and destroy the components.

## 4. INSTALL THE CONNECTING PIPE

Check whether the height drop between the indoor unit and outdoor unit, the length of refrigerant pipe, and the number of the bends meet the following requirements:

## 4.1 Refrigerant piping



## CAUTION

Please pay attention to avoid the components while connect to the connecting pipes.

To prevent the refrigerant piping from oxidizing inside when welding, it is necessary to charge nitrogen, or oxide will chock the circulation system.

### The indoor and outdoor connecting pipe interface and power line outlet

Vavious piping and viring patterns can be selected, such as out from the front, the back the side, and undersurface, etc. (The follow display the locations of several piping and wiring knock-off interfaces)

Table 4-1

Front out pipe	Side out pipe	Back out pipe	Undersurface out pipe



## CAUTION

Side out pipe: please remove the L-shape metal plate, otherwise can not wiring.

Back out pipe: Please wipe off the piping support rubber blanket beside the inner outlet pipe cover of the machine while back side getting out pipes.

Undersurface outlet pipe: the knock out should from inside to outside, and then piping and wiring through this. Pay attention to the piping the fat connecting pipe should out from the largest hole, otherwise the pipes will be rubbed. Please do the moth proofing for the knocked out hole, to avoid the pest processing into and destroy the components.

## 4.2 Leak Detection

Use soap water or leak detector to check every joint whether leak or not (Refer to Fig.4-2). Note:

A is low pressure side stop valve

B is high pressure side stop valve

C and D is connecting pipes interface of indoor and outdoor units

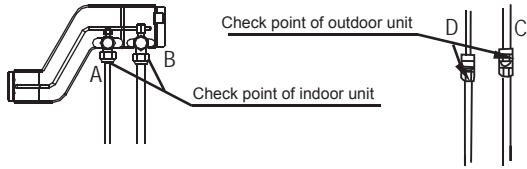

Fig. 4-2

### 4.3 Heat Insulation

Do the heat insulation to the pipes of air side and liquid side separately. The temperature of the pipes of air side and liquid side when cooling, for avoiding condensation please do the heat insulation fully.

- The air side pipe should use closed cell foamed insulation material, which the fire-retardant is B1 grade and the heat resistance over 120°C.
- When the external diameter of copper pipe  $\leq \Phi 12.7\text{mm}$ , the thickness of the insulating layer at least more than 15mm;
- When the external diameter of copper pipe  $\geq \Phi 15.9\text{mm}$ , the thickness of the insulating layer at least more than 20mm.
- Please use attached heat-insulating materials do the heat insulation without clearance for the connecting parts of the indoor unit pipes.

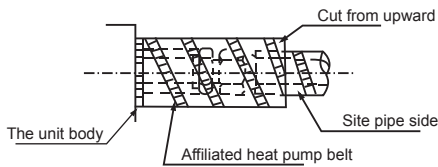

Fig. 4-3

### 4.4 Connecting method

- Select refrigerant pipe

Table 4-2

pipe definition	pipe connect position	code
main pipe	The pipe between outdoor unit to the first branch of indoor unit.	L1
The main pipes of indoor unit	The pipe after the first branch do not direct connect with the indoor unit.	L2~L5
The branch pipes of indoor unit	The pipe after the branch connect with the indoor unit.	a, b, c, d, e, f
Indoor unit branch pipes components	The pipes connect with the main pipe, the branch pipe and the the main pipe of indoor unit.	A, B, C, D, E

- The first connect method

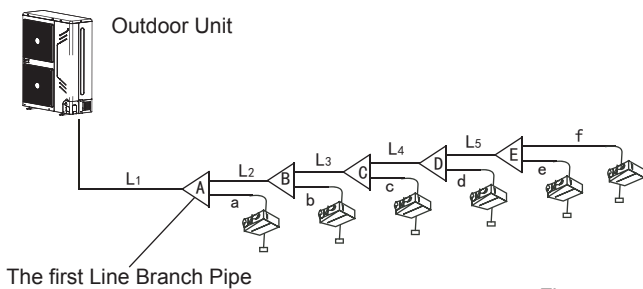

Fig. 4-4

- The second connect method

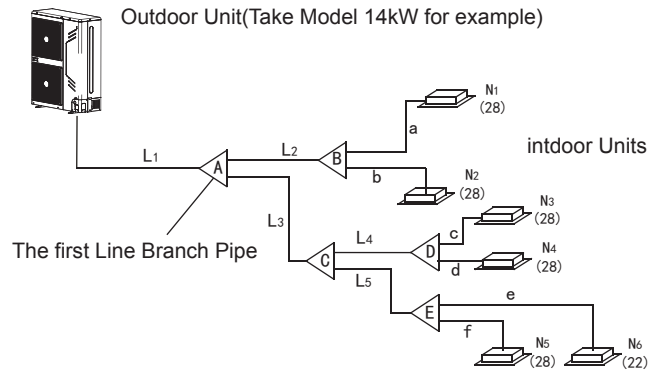

Fig. 4-5



### NOTE

- The distance between the first branch to the last indoor unit is more than 15m, choose the second connect method.
- The pipe between the indoor unit to the closest branch must less than 15m.

### 4.4 Confirmation for the diameters of indoor unit connecting pipes

- Size of main pipe and corresponding branch joint and branch header

- 1) R410A Indoor unit connecting pipes diameters 4-3.
- 2) Example 1: In the Fig.4-5, The downstream inner units of the L2, and its total capacity is  $28 \times 2 = 56$ , refers to the Table 4.4, the air/liquid side of L2 is:  $\Phi 15.9/\Phi 9.5$ .

R410A Indoor unit connecting pipes diameters

Table 4-3

Total capacity of The downstream inner units	main pipe size (mm)		Branch Pipe
	air pipe	liquid pipe	
$A < 166$	$\Phi 15.9$	$\Phi 9.5$	FQZHN-01C
$166 \leq A < 230$	$\Phi 19.1$	$\Phi 9.5$	FQZHN-01C

### 4.5 Confirmation for the diameters of outdoor unit connecting pipes

R410A outdoor unit connecting pipes diameters

Table 4-4

Total capacity of The outdoor units	Main pipe size when the total equivalent piping length of liquid + air side is $< 90\text{m}$			Main pipe size when the total equivalent piping length of liquid + air side is $\geq 90\text{m}$		
	air side (mm)	liquid side (mm)	The first Line Branch Pipe	air side (mm)	liquid side (mm)	The first Line Branch Pipe
$A < 160$	$\Phi 15.9$	$\Phi 9.5$	FQZHN-01C	$\Phi 19.1$	$\Phi 9.5$	FQZHN-01C
$160 \leq A < 230$	$\Phi 19.1$	$\Phi 9.5$	FQZHN-01C	$\Phi 22.2$	$\Phi 9.5$	FQZHN-02C



### NOTE

- The straight distance between copper pipe turning and the contiguous branch pipe is at least 0.5m;

- The straight distance between the contiguous branchpipes is at least 0.5m;
- The straight distance which the branch pipes connected to the indoor unit is at least 0.5m;
- Branch header must be connected with indoor units directly, the further branch connection is not allowed.

● Select branch joint

Select the branch joint according to the total designed capacity of indoor units which it connects to. If this capacity is more than that of the outdoor unit, then select the connection according to the outdoor unit.

- The selection of branch header depends on the quantity of branches it connects to.

■ Connection method

Table 4-5

	Gas side	Liquid side
10.5kW	Flaring	Flaring
14kW	Flaring	Flaring
Indoor unit	Flaring	Flaring
Branch pipe	Welding or Flaring	Welding or Flaring

■ Piping sizes at the branch pipe

Table 4-6 (A: the total capacity of indoor units)

Refrigerant	A (TYPE)	Gas Side (Φ)	Liquid Side (Φ)
R410A	Wall mounted 22~45	12.7(Flaring nut)	6.4(Flaring nut)
	Wall mounted 56	15.9(Flaring nut)	9.5(Flaring nut)
	Four way cassette type 71~160	15.9(Flaring nut)	9.5(Flaring nut)
	Four way cassette compact type 22~45	12.7(Flaring nut)	6.4(Flaring nut)
	Four way cassette compact type 56	15.9(Flaring nut)	9.5(Flaring nut)
	Duct type 22~45	12.7(Flaring nut)	6.4(Flaring nut)
	Duct type 56~140	15.9(Flaring nut)	9.5(Flaring nut)
	Ceiling & Floor 36~45	12.7(Flaring nut)	6.4(Flaring nut)
	Ceiling & Floor 56~160	15.9(Flaring nut)	9.5(Flaring nut)

■ Pipe diameter of the connector in the outdoor unit's body

Table 4-7

MODEL (kW)	Piping side	Pipe diameter of outdoor unit's connector(mm)	
		Gas Side	Liquid Side
10.5		Φ 15.9	Φ 9.5
14		Φ 15.9	Φ 9.5

Table 4-8

Outdoor Unit (kW)	Capacity of Outdoor unit (horsepower)	Maximum Quantity of Indoor unit	Sum Capacity of Indoor unit (horsepower)
10.5	4	5	45%~130%
14	5	6	45%~130%

(The quantity of indoor unit more than or equal to two, each indoor unit of capacity should be not more than 8.0kW.)

When capacity of indoor unit greater than the sum of 100%, capacity of indoor unit will be attenuated.

When capacity of indoor unit greater than or equal to the sum of 120%, in order to ensure the effectiveness of machine, and then try to open the indoor units at different time.

When the capacity of indoor unit is greater than or equal to 16.8kW, the caliber of primary gas pipe should be augmented from Φ16 to Φ19.

Table 4-9

Capacity ranking(kW)	Capacity (horsepower)
10.5	4
14	5

■ When the outdoor unit connects one indoor unit

Table 4-10

MODEL (kW)	The max height drop(m)		The length of refrigerant pipe(m)	The number of bends
	When outdoor unit is top	When outdoor unit is bottom		
10.5	25	20	50	less than 10
14	25	20	50	

## 4.6 Illustration

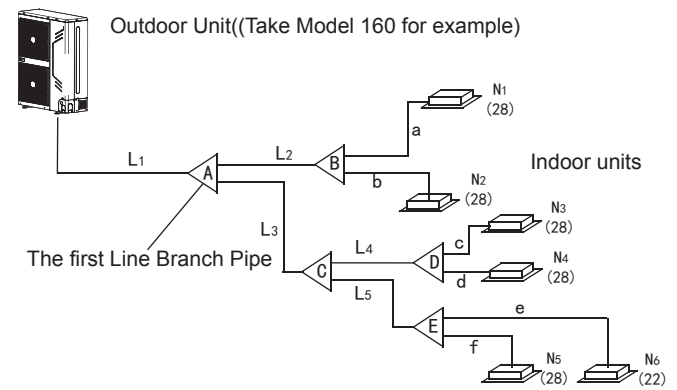

Fig.4-6

Caution: Suppose in the displayed piping system, the total equivalent piping length of air side + liquid side is longer than 90m.

● Indoor unit branch pipe

Inner branch pipes are a~f, the size selection please refers to Table4-6. Note: The max. length of the branch pipe should not longer than 15m.

● The main pipes of indoor unit and the indoor unit branch pipe components

■ The downstream inner units of the main pipe L2 are N1, N2, and its total capacity is 28×2=56, the size of pipe L2 is Φ15.9/Φ9.5, and the branch pipe B should be FQZHN-01C.

■ The downstream inner units of the main pipe L4 are N3, N4, and its total capacity is 28×2=56, the size of pipe L4 is Φ15.9/Φ9.5, and the branch pipe D should be FQZHN-01C.

■ The downstream inner units of the main pipe L5 are N5, N6, and its total capacity is 28+22=50, the size of pipe L5 is Φ15.9/Φ9.5, and the branch pipe E should be FQZHN-01C.

■ The indoor unit below to the main pipe L3 are N3~N6, and its total capacity is 28×3+22=106, the size of pipe L3 is Φ15.9/Φ9.5, and he branch pipe C should be FQZHN-01C.



- The indoor unit below to the main pipe A are N1~N6, and its total capacity is  $28 \times 5 + 22 = 162$ , and the branch pipe should be FQZHN-01C, and because the total piping length of liquid + air side is  $\geq 90\text{m}$ , check Table.4-4, and the first branch pipe should apply FQZHN-02C, and according to the principle of maximum value, it should apply FQZHN-02C.

- Main pipe (Please refer to Fig.4-5 and Fig.4-7)

In Fig.4-6, the main pipe L1, the outdoor unit capacity is 16kW, and check the Fig.4-7 to get the size of gas pipe/liquid pipe is  $\Phi 19.1/\Phi 9.5$ , and also the total equivalent length of liquid side and gas side pipes is  $> 90\text{m}$ , then check the Fig.4-4 to get the size of gas pipe/liquid pipe is  $\Phi 22.2/\Phi 9.5$ , and according to the maximum value principle, it should apply the  $\Phi 22.2/\Phi 9.5$ .

- Allowable length and altitude difference of refrigerant pipe

table 4-11

		Permitted value	Piping	
Pipe Length	Total Pipe Length(Actual)	$\leq 100\text{m}$	$L1+L2+L3+L4+L5+a+b+c+d+e+f$	
	Maximum Piping(L)	Actual Length	$\leq 45\text{m}$ (10.5kW) $\leq 60\text{m}$ (14kW)	$L1+L2+L3+L4+L5+f$ (The first connect method) or $L1+L3+L5+f$ (The second connect method)
		Equivalent Length	$\leq 50\text{m}$ (10.5kW) $\leq 70\text{m}$ (14kW)	
	Pipe Length(from the first line branch pipe to furthest indoor unit)(m)	$\leq 20\text{m}$	$L2+L3+L4+L5+f$ (The first connect method) or $L3+L5+f$ (The second connect method)	
	Pipe Length(from the nearest branch pipe equivalent length(m)	$\leq 15\text{m}$	a, b, c, d, e	
Drop Height	Indoor Unit-Outdoor Unit Drop Height(H)	Outdoor Unit up	$\leq 30\text{m}$	_____
		Indoor Unit Down	$\leq 20\text{m}$	_____
	Indoor Unit to Indoor Unit Drop Height(H)	$\leq 8\text{m}$	_____	_____

Note: When the total equivalent piping length of liquid + gas side is  $\geq 90\text{m}$ , it must increase the size of air side main pipe. Besides, according to the distance of refrigerant pipe and the over matched state of inner unit, when the capacity is decreasing it still can increase the gas side main pipe size.

- The first connect method

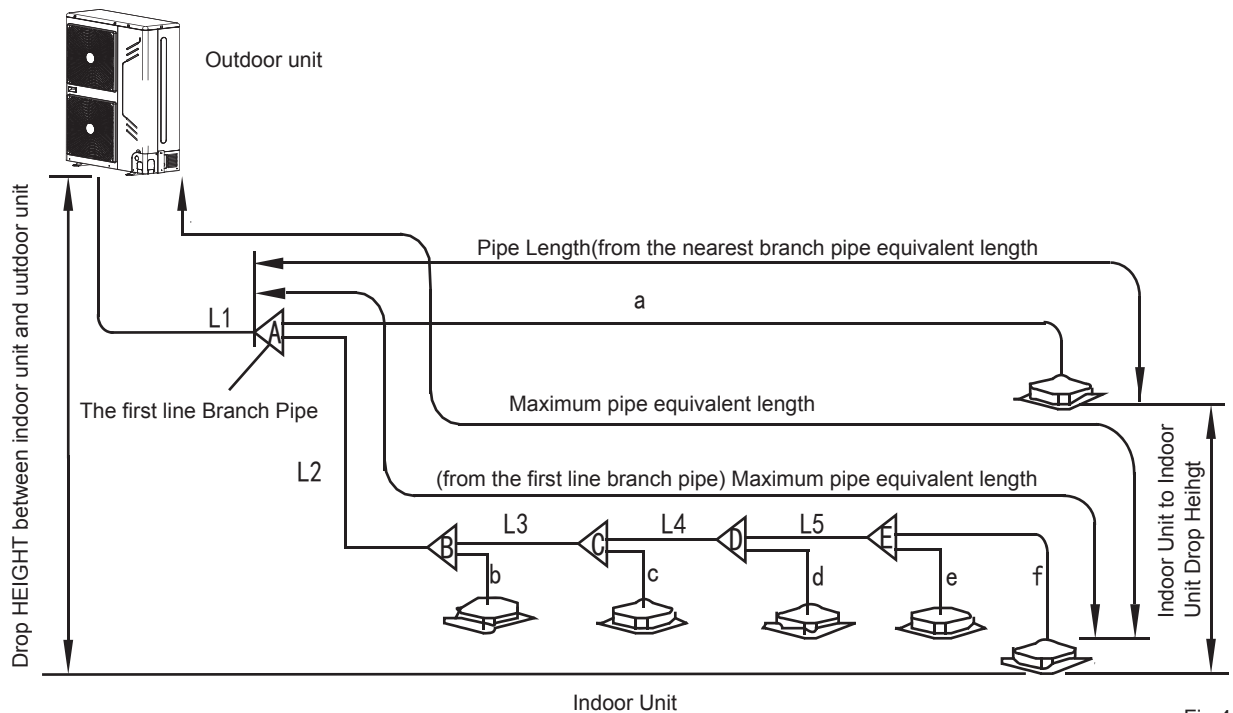

Fig.4-7

- The second connect method

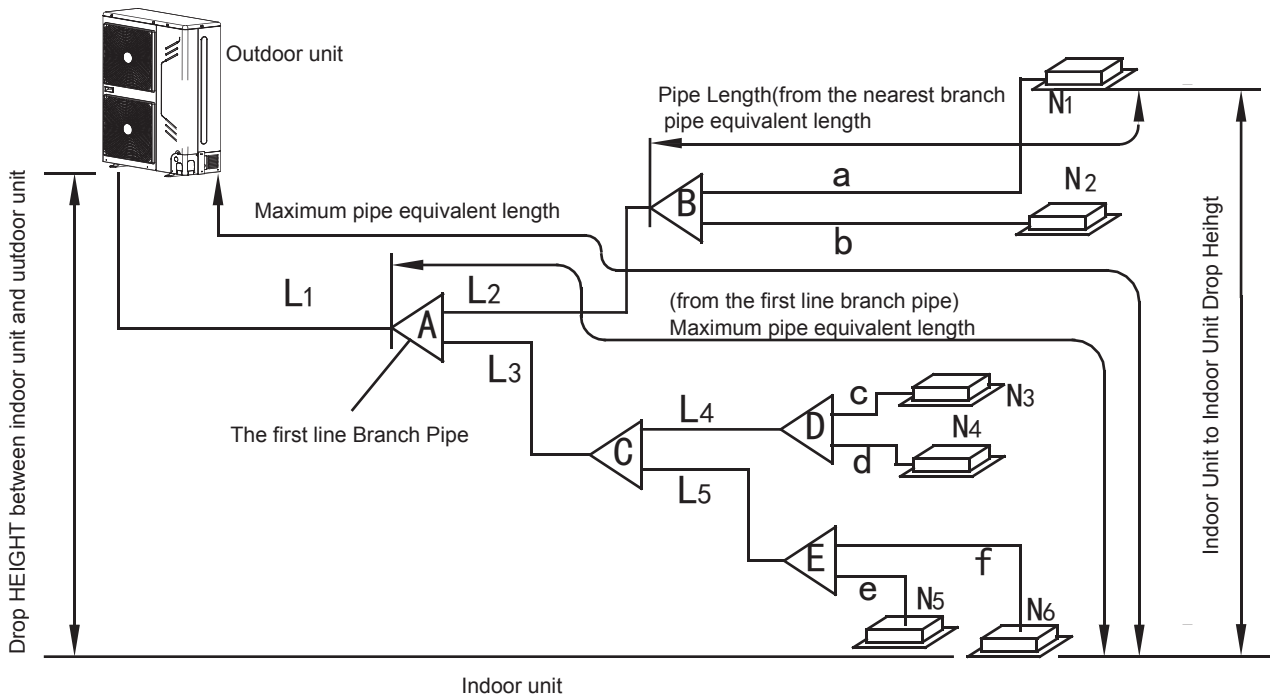

Fig.4-8

#### 4.7 Remove Dirt or Water in the Piping

Make sure there is no any dirt or water before connecting the piping to the outdoor units.

Wash the piping with high pressure nitrogen, never use refrigerant of outdoor unit.

#### 4.8 Airtight Test

Charge pressured nitrogen after connecting indoor/outdoor unit piping to do airtight test.



#### CAUTION

1. Pressured nitrogen [ 4.3MPa (44kg/cm<sup>2</sup>) for R410A] should be used in the airtight test.
2. Tighten high pressure/low pressure valves before applying pressured nitrogen.
3. Apply pressure from air vent mouth on the high pressure/low pressure valves.
4. The high pressure/low pressure valves are closed when applying pressured nitrogen.
5. The airtight test should never use any oxygen, flammable gas or poisonous gas.

#### 4.9 Air Purge with Vacuum Pump

- Using vacuum pump to do the vacuum, never using refrigerant to expel the air.
- Vacuuming should be done from both liquid side and gas side simultaneously.

#### 4.10 Refrigerant Amount to be Added

Calculate the added refrigerant according to the diameter and the length of the liquid side pipe of the outdoor unit/indoor unit connection.

- When the outdoor unit connects 1 indoor unit:

Table 4-12

Liquid Side Piping Diameter	Refrigerant to be Added Per meter Piping
Φ6.4	0.023kg
Φ9.5	0.060kg
Φ12.7	0.120kg
Φ15.9	0.180kg
Φ19.1	0.270kg
Φ22.2	0.380kg



#### NOTE

Additional refrigerant volume of divergent pipe is 0.1kg per item (Consider the liquid side of divergent pipe only)

# 5. ELECTRICAL WIRING

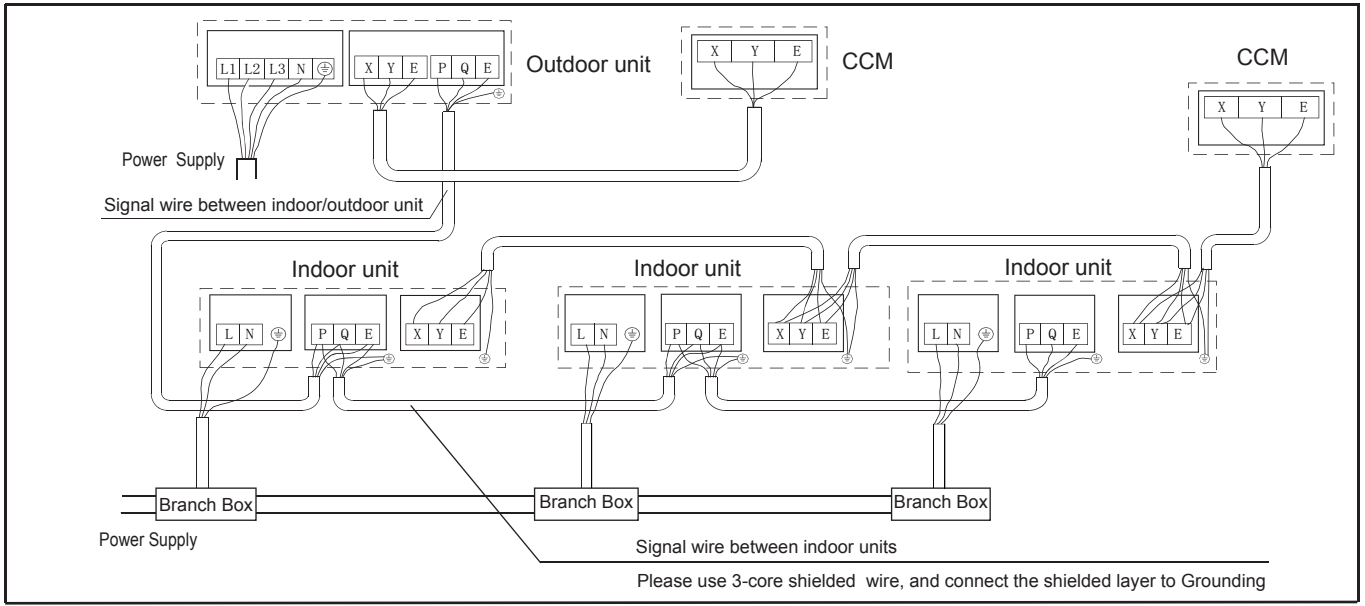

Fig. 5-1

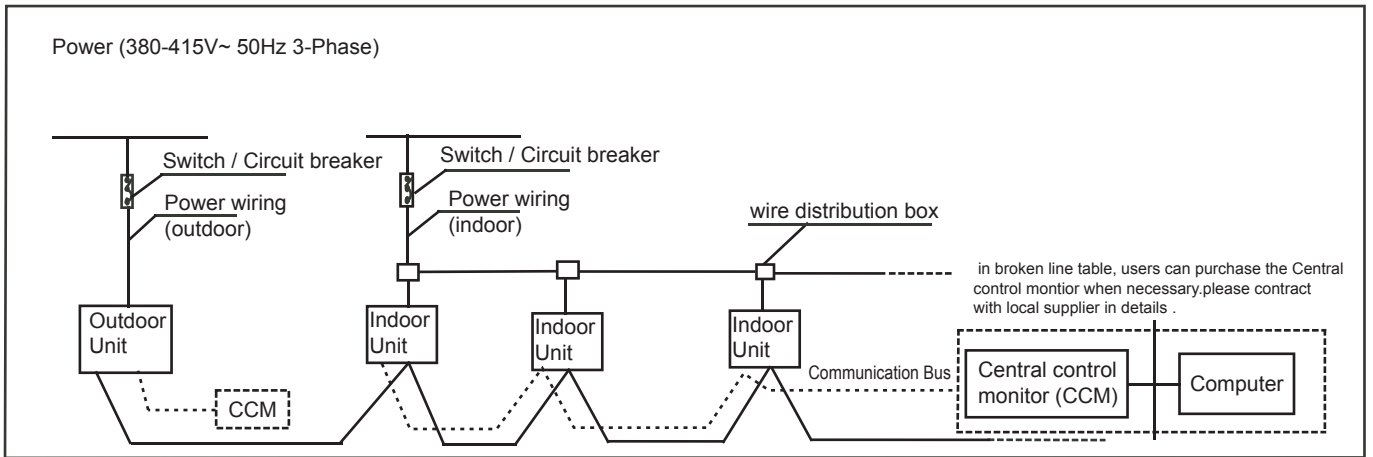

Fig. 5-2



## CAUTION

- Please select power source for indoor unit and outdoor unit respectively
- The power supply has specified branch circuit with leakage protector and manual switch.
- The outdoor unit model which corresponding to different outdoor unit power supply should refer to the nameplate. (Please set all the indoor unit power of one system into the same branch circuit.)
- Please put the connective wire system between indoor unit and outdoor unit with the refrigerant system together.
- Use 3-core shielded wire as indoor unit and outdoor unit signal wire.
- The installation should comply with local electric standard.
- Power wiring should be engaged by specialized electrician.

## 5.1 Outdoor Unit Wiring

### ■ The Specification of Power

Table 5-1

Power Source	380-415V 3Ph~ 50Hz	
Capacity(kW)	10.5	14
Power Wiring Size	Wire size must comply with local codes	
Circuit Breaker (A)	25	25
Indoor unit/ Outdoor unit Signal wire (mm <sup>2</sup> ) (Weak electric signal)	3-core shielded wire 3X0.75	



## CAUTION

Equipment complying with IEC 61000-3-12. A disconnection device having an air gap contact separation in all active conductors should be incorporated in the fixed wiring according to the National Wiring Regulation.



## CAUTION

The reserved function is indicated in broken line table, users can select it when necessary.

### Indoor/Outdoor Unit Signal Wire

Connect the wire according to their numbers.

Wrong connection may cause malfunction.

### Wiring Connection

Seal the wiring connection with the insulation material, or the condensing dew will be caused.



## NOTE

The air-conditioners can connect with Central Control Monitor (CCM). Before operation, please wiring correctly and set system address and network address of indoor units.

## 5.2 Indoor Unit Wiring

### ● Power Supply

Table 5-2

Capacity(kW)		2.2~8
Indoor Unit Power	Phase	1-Phase
	Voltage and Frequency	220-240V~ 50Hz
	Power Wiring Size	Wire size must comply with local codes
Circuit Breaker (A)		16
Indoor Unit /Outdoor Unit Signal Wire (mm <sup>2</sup> ) (Weak electric signal)		3-core shielded wire 3X0.75

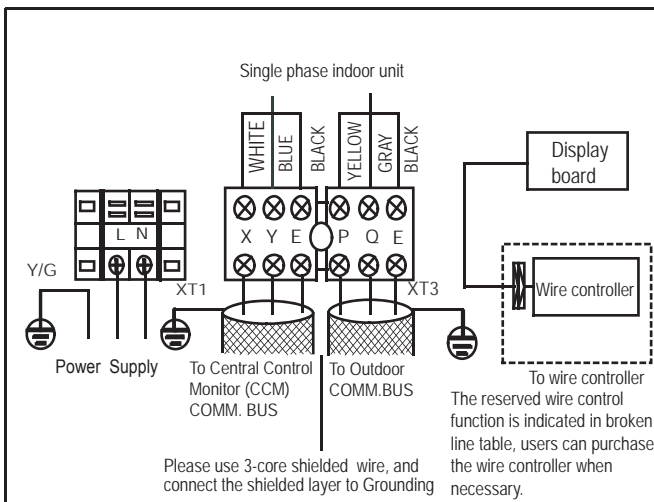

Fig. 5-5

- Signal wire is 3-core, polarized wire. Use 3-core shield wire to prevent interference. The grounding method now is grounding the closed end of the shield wire and opening (insulating) at the end. Shield is to be grounded.
- The control between outdoor unit and indoor unit is BUS type. Addresses is set on field during the installation.



## CAUTION

Indoor/Outdoor unit signal wire is low voltage circuit. Do not let it touch the high voltage power wire and put it to gather with power cord in the same wire distribution pipe.



## NOTE

The wire diameter and continuous length is under the condition that the voltage vibration is within 2%. If the continuous length is exceed showing value, choose the wire diameter follow relevant regulation.

## Indoor unit power supply wiring

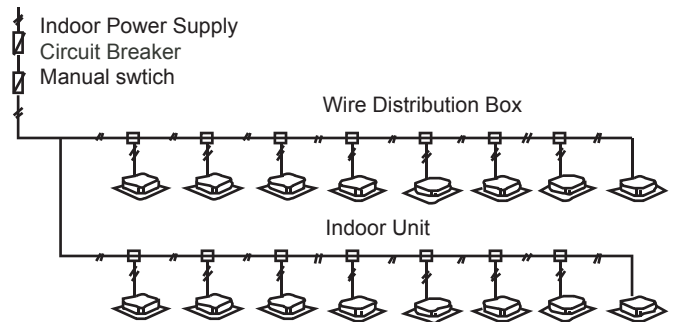

Fig. 5-6



## CAUTION

- Refrigerant piping system, indoor unit-indoor unit connection signal wires and indoor unit-outdoor unit connection signal wire are in the same system.
- When power cord is parallel with signal wire, please put them into separate wire distribution pipes, and leave a proper distance. (Reference distance: It is 300mm when current capacity of power cord is less than 10A, or 500mm when 50A).

- Please use shield wire as indoor unit/outdoor unit signal wire.

## Indoor/Outdoor unit signal wire wiring

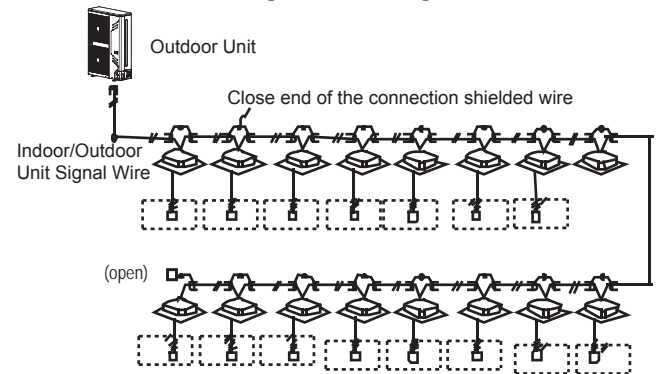

in broken line table, users can purchase the wire controller when necessary.

Fig. 5-7

## 6. TEST RUNNING

Operate according to "gist for test running" on the electric control box cover.

### CAUTION

- Test running can not start until the outdoor unit has been connected to the power for 12hr.
- Test running can not start until all the valves are affirmed open.
- Never make the forced running. (Or the protector sits back, danger will occur.)

## 7. PRECAUTIONS ON REFRIGERANT LEAKAGE

This air conditioner(A/C) adopts innocuous and nonflammable refrigerant. The locating room of the A/C should big enough that any refrigerant leakage is unable to reach critical thickness. So certain essential action can be taken on time.

- Critical thickness-----the Max. thickness of Freon without any harm to person.
- Refrigerant critical thickness: 0.44[kg/m<sup>3</sup>] for R410A.

Confirm the critical thickness through follow steps, and take necessary actions.

1. Calculate the sum of the charge volume (A[kg]) Total Refrigerant volume of 10HP=factory refrigerant volume + superaddition
2. Calculate the indoor cubage (B[m<sup>3</sup>]) (as the minimum cubage).
3. Calculate the refrigerant thickness

$$\frac{A[\text{kg}]}{B[\text{m}^3]} \leq \text{critical thickness}$$

Counter measure against over high thickness

1. Install mechanical ventilator to reduce the refrigerant thickness under critical level. (ventilate regularly)
2. Install leak alarm facility related to mechanical ventilator if you can not regularly ventilate.

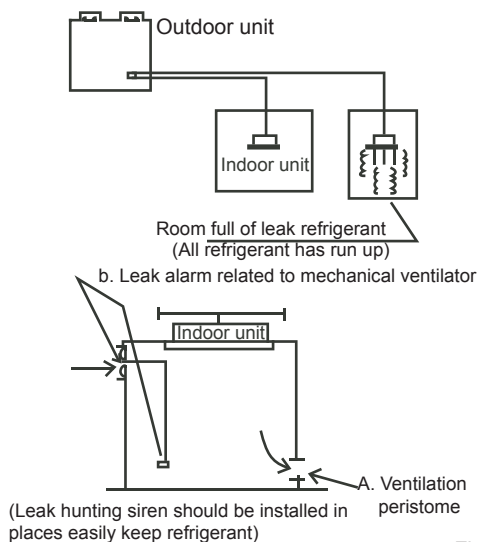

Fig. 7-1



## NOTE

Please press "constraint cool" button to carry out refrigerant recycling process. Keep the low pressure above 0.2MPa, other wise compressor may be burnt out.

## 8. TURN OVER TO CUSTOMER

The owner's manual of indoor unit and owner's manual of outdoor or unit must be turned over to the customer. Explain the contents in the owner's manual to the customers in details.



Air Conditioning Systems

Cooling & Heating

**TRUST AIR-CONDITIONING EQUIPMENT CO.**

Shiraz office: 8 th floor, Alvand Bldg., Dostan St.,  
Moaliabad Ave., SHIRAZ, IRAN., Post code: 71877-14446

Tel.: +98-71-36341070

Fax.: +98-71-36341094

Tehran office: No. 19- koohe nour St.- Motahhari St.-

TEHRAN, IRAN., Post code: 15876-73111

Tel.: +98-21-89389

Fax.: +98-21-88541903

Ahwaz office: No. 309- Kaveh St.- AHWAZ, IRAN., Post code: 61939-47911

Tel.: +98-61-32230647-8 E-mail: [info@trustacs.com](mailto:info@trustacs.com)

Fax.: +98-61-32230647 Web site: <http://www.trustacs.com>

برند برتر در اولین جشنواره بین المللی  
برترین نام و نشان های تجاری ایران

