

FAN COIL UNIT (FOUR WAY CASSETTE)



TRUST AIR CONDITIONING EQUIPMENT CO.
Prepared By: Engineering & R & D Department.

Content

1. INSTALLATION- 2-

توجه:
شرکت تراست حق تغییر مشخصات دستگاه ها را در جهت بهبود و ارتقای

1. Installation

1.1 Before installation

Please check whether the accessories are of full scope. If there are some fittings free from use, please restore them carefully.

1.2 Installation space

The indoor unit should be installed in a location that meets the following requirements:

- There is enough room for installation and maintenance.
- The ceiling is horizontal, and its structure can endure the weight of the indoor unit.
- The outlet and the inlet are not impeded, and the influence of external air is the least.
- The air flow can reach throughout the room.
- The connecting water pipe and drainpipe could be extracted out easily.
- There is no direct radiation from heaters.

Caution: Keep indoor unit, outdoor unit, power supply wiring and transmission wiring at least 1 meter away from televisions and radios.

This is to prevent image interference and noise in those electrical appliances. (Noise may be generated depending on the conditions under which the electric wave is generated, even if 1 meter is kept.)

1.3 Installation procedures for fresh air intake duct connection

Preparing the connection hole

- Cut off the knockout hole on the side plate with a nipper.
- Cut the inner insulation of the hole portion with a cutter.

Placing the insulation

- Put the insulation tightly around the hole of the unit as shown. The ends of the side plate and the inner insulation must be completely adhered without leaving any clearance along the circumference of the hole. Make sure the inner surface of insulation tightly contacts the inner insulation edge and the side plate. (refer to fig.11.5)

1.4 Install the main body

A. The existing ceiling (to be horizontal)

- a. Cut a quadrangular hole of 880×880mm in the ceiling according to the shape of the installation paper board.
 - The center of the hole should be at the same position of that of the air conditioner body.
 - Determine the lengths and outlets of the connecting pipe, drain pipe and cables.
 - To balance the ceiling and to avoid vibration, please enforce the ceiling when necessary.
- b. Select the position of installation hooks according to the hook holes on the installation board.
 - Drill four holes of Ø12mm, 50~55mm deep at the selected positions on the ceiling. Then embed the expansible hooks (fittings).
 - Face the concave side of the installation hooks toward the expansible hooks. Determine the length of the installation hooks from the height of ceiling, and then cut off the unnecessary part.
 - If the ceiling is extremely high, please determine the length of the installation hook according to facts.
- c. Adjust the hexangular nuts on the four installation hooks evenly, to ensure the balance of the body.
 - If the drainpipe is awry, leakage will be caused by the malfunction of the water-level switch.
 - Adjust the position to ensure the gaps between the body and the four sides of ceiling are even. The body's lower part should sink into the ceiling for 10~12 mm (refer to fig.11.6).
 - In general, L is half of the screw length of the installation hook. (refer to fig.11.6)
 - Locate the air conditioner firmly by wrenching the nuts after having adjusted the body's position well. (refer to fig.11.7)

B. New built houses and ceilings

- a. In the case of new built house, the hook can be embedded in advance (refer to the A.b mentioned above). But it should be strong enough to bear the indoor unit and will not become loose because of concrete shrinking.

- b. After installing the body, please fasten the installation paper board onto the air conditioner with bolts (M6×12) to determine in advance the sizes and positions of the hole opening on ceiling. (refer to fig.11.8)
- Please first guarantee the flatness and horizontal of ceiling when installing it.
 - Refer to the A.a mentioned above for others.
- c. Refer to the A.c mentioned above for installation.
- d. Remove the installation paper board.

Caution: After installing the body, the four bolts (M6×12) must be fastened to the air conditioner onto ensure the body is grounded well.

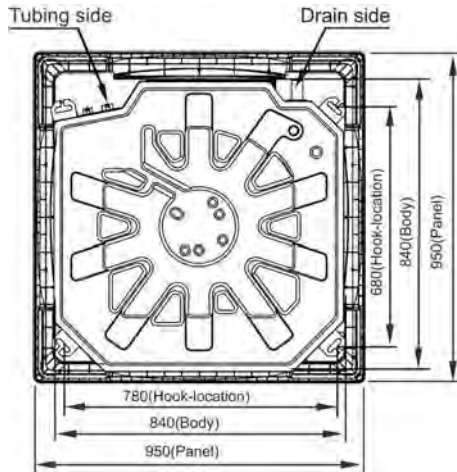

fig. 1.1

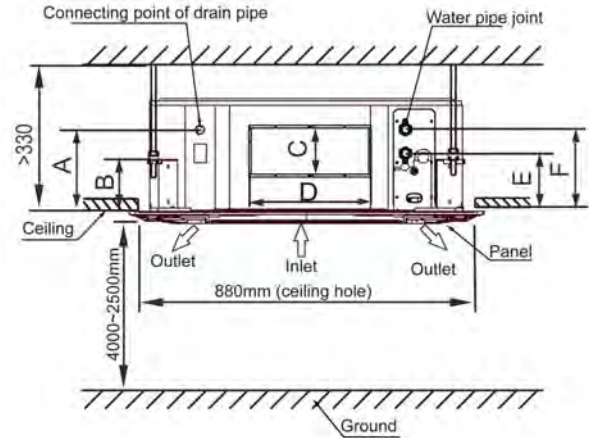

fig. 1.2

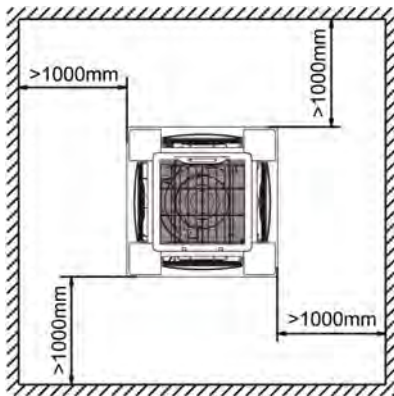

fig. 1.3

Table 11.1

Model	A	B	C	D	E	F
600CFM, 750CFM	180	140	85	350	145	195
850CFM, 950CFM, 1200CFM, 1500CFM	180	140	155	350	155	205

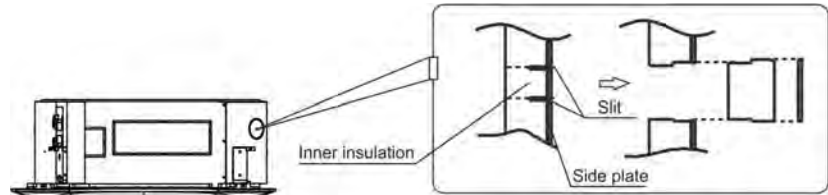

fig. 1.4

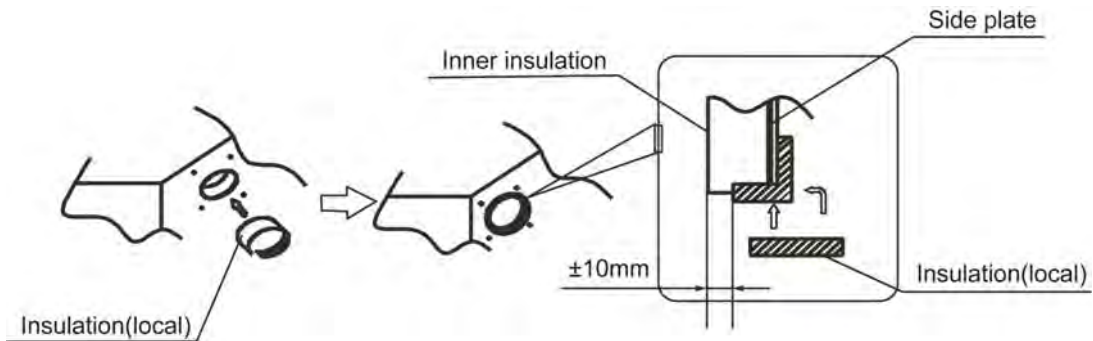

fig. 1.5

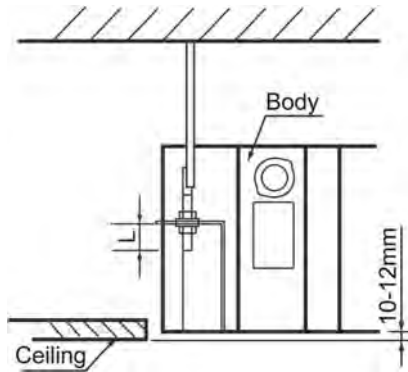

fig. 1.6

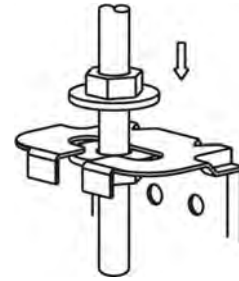

fig. 1.7

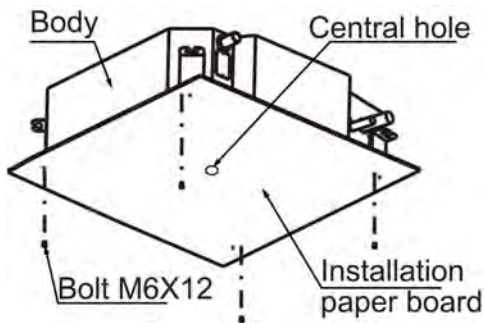

fig. 1.8

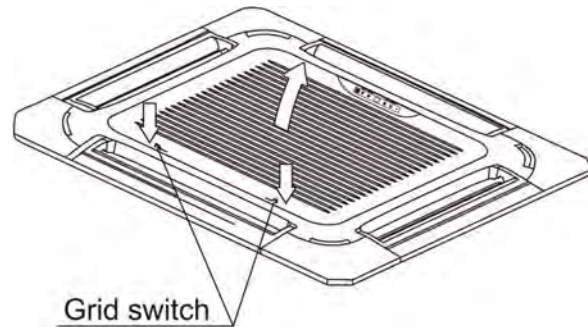

fig. 1.9

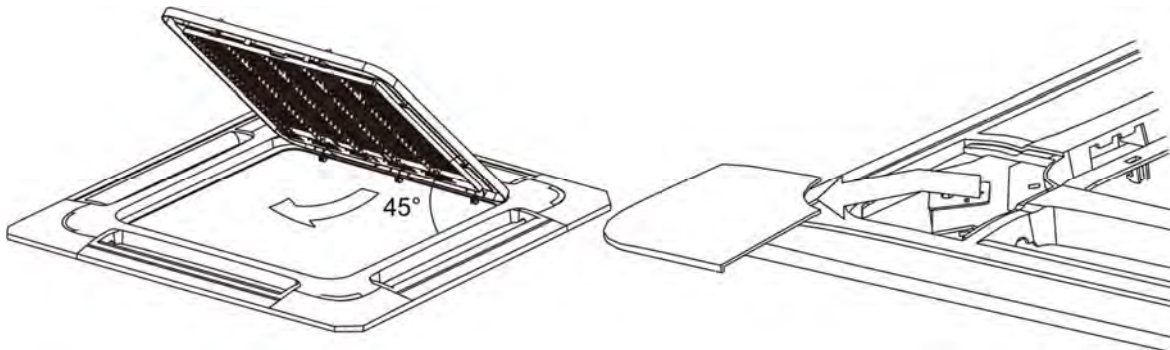

fig. 1.10

1.5 Install the panel

Caution:

Never put the panel face down on floor or against the wall, or on bulgy objects.

Never crash or strike it.

(1) Remove the air inlet grill.

a. Slide two grid switches toward the middle at the same time, and then pull them up. (refer to fig. 11.9)

b. Draw the grid up to an angle of about 45°, and remove it. (refer to fig. 11.10)

(2) Remove the installation covers at the four corners.

Wrench off the bolts, loose the rope of the installation covers, and remove them. (refer to fig. 11.10)

(3) Install the panel

a. Align the swing motor on the panel to the tubing joints of the body properly.

b. Fix hooks of the panel at swing motor and its opposite sides to the hooks of corresponding water receiver. Then hang the other two panel hooks onto corresponding hangers of the body.

Caution: Do not coil the wiring of the swing motor into the seal sponge.

c. Adjust the four panel hook screws to keep the panel horizontal, and screw them up to the ceiling evenly.

- d. Regulate the panel in the direction of the arrow slightly to fit the panel's center to the center of the ceiling's opening. Guarantee that hooks of four corners are fixed well.
- e. Keep fastening the screws under the panel hooks, until the thickness of the sponge between the body and the panel's outlet has been reduced to about 4~6mm. The edge of the panel should contact with the ceiling well.
 - If the gap between the panel and ceiling still exists after fastening the screws, the height of the indoor unit should be modified again.
 - You can modify the height of the indoor unit through the openings on the panel's four corners; if the lift of the indoor unit and the drainpipe is not influenced.

(4) Hang the air-in grid to the panel, and then connect the lead terminator of the swing motor and that of the control box with corresponding terminators on the body respectively.

(5) Relocate the air-in grid in the procedure of reversed order.

(6) Relocate the installation cover.

- a. Fasten the rope of installation cover on the bolt of the installation cover.
- b. Press the installation cover into the panel slightly.

1.6 Connect the Drain Pipe

Install the drainpipe of the indoor unit

- The drainpipe can use PVC pipe (external diameter about 37~39mm, inner diameter is 32mm).
- Joint drainpipe connector to the end side of water pumping pipe, and fix drainpipe together with water outflow pipe and thermal insulation tube by clasp of water outflow pipe (attached).

Caution: Don't use forcing strength to crack the water-pumping pipe.

- Water-pumping pipe and drainpipe from main body must be wrapped by insulation tube evenly, and bound by tighten band for obstructing air getting in and coagulation.
- Prevent from water backflow into unit inside during shutdown, the drain pipe shall place down side and drain water to outdoor (drain side), the gradient of the drain pipe should be higher than (1/100), without salient and water remain.(refer to fig.11.11a)
- When connecting drainpipe, don't drag the pipe that would pull the main unit. For this, please arrange bearing points every 0.8 to 1.0 meter to avoid pipe be bended (refer to fig.11.11b).
- When connect a lengthen drainpipe, apply protective tube to wrap its indoor parts for ensuring the lengthen part connected tightly.
- In case the drainpipe outlet is higher than pumping connective pipe of the main body, the drainpipe must be arranged upwards vertically by using connective assembly of the water outlet for vertical bending, and the height of the drainpipe shall set to the defrosting pan surface no more than 1000mm, otherwise, too much backflow while shutdown would leads to overflow (refer to fig.11.12).
- Base on the actual requirement to bend piping, and use connective assembly of water outlet in terminal box for pipe layout.

Caution: The joints in drain system must be sealed to avoid water leakage.

- The height from floor to the end of drainpipe or the bottom of drain slot must more than 50 mm. Don't immerse the end of drainpipe or the bottom of drain slot into water. When drain condensate liquid to raceway, please bend the drainpipe to a U-sharped hydroseal for avoiding stench transmitted by drainpipe to indoor.

Note: All the pictures in this manual are for explanation purpose only. They may be slightly different from the air-conditioner you purchased (depend on model).The actual shape shall prevail.

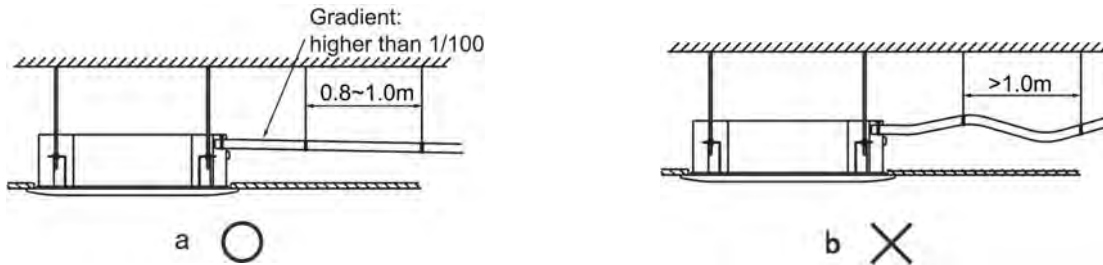

fig. 1.11

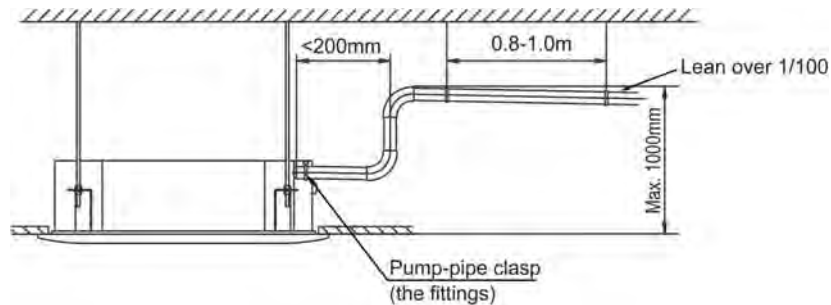

fig. 1.12

Drainage test

- Check whether the drainpipe is unhindered.
- New built house should have this test done before paving the ceiling.
 1. Remove the test cover, and stow water of about 2000ml to the water receiver through the stow tube.
 2. Turn on the power, and operate the air conditioner under the "COOLING" mode. Listen to the sound of the drain pump. Check whether the water is discharged well (a lag of 1min is allowed before discharging, according to the length of the drain pipe), and check whether water leaks from the joints.

Cautions: If there is any malfunction, please resolve it immediately.

3. Stop the air conditioner for three minutes, check if everything is ok. If the drain hose is located unreasonable, water overflow will cause the Alarm indicator lamp flashing (For both cooling and heating type or cooling only type), even the water leak out from the water receiver.
 4. Check the drain pump whether drain water immediately when alarm sound for the high water lever. If the water lever can't come down below to the limited water lever, the air conditioner will stop. Restart it until turn off the power and drain off all the water.
 5. Turn off the power, drain the water away.
- The drain plug is used to empty the water-receiver for maintenance of the air conditioner. Please stuff it imposition at all times during operation to avoid leakage.

1.7 Wiring

Caution:

- The air conditioner should use separate power supply with rated voltage.
- The external power supply to the air conditioner should have ground wiring, which is linked to the ground wiring of the indoor and outdoor unit.
- The wiring work should be done by qualified persons according to circuit drawing.
- An all-pole disconnection device which has at least 3mm separation distance in all pole and a residual current device (RCD) with the rating of above 10mA shall be incorporated in the fixed wiring according to the national rule.
- The appliance shall be installed in accordance with national wiring regulations.
- Be sure to locate the power wiring and the signal wirings well to avoid cross-disturbance.
- Do not turn on the power until you have checked carefully after wiring.

Note: Remark per EMC Directive 2004/108/EC for to prevent flicker impressions during the start of the compressor (technical process), following installation conditions do apply.

- 1.The power connection for the air conditioner has to be done at the main power distribution. The distribution has to be of low impedance; normally the required impedance reaches at a 32A fusing point.
- 2.No other equipment has to be connected with this power line.
- 3.For detailed installation acceptance please refer to your power supplier, if restrictions do apply for products like washing machines, air conditioners or electrical ovens.
- 4.For power details of the air conditioner refer to the rating plate of the product.
- 5.For any question contact your local dealer.

Connect the cable

- Disassemble the bolts from the cover.(If there isn't a cover on the outdoor unit, disassemble the bolts from the maintenance board, and pull it in the direction of the arrow to remove the protection board.)
- Connect the connective cables to the terminals as identified with their respective marked numbers on the terminal block of indoor and outdoor units.
- Re-install the cover or the protection board.

AIR FLOW(m ³ /h)		510~2550
POWER	PHASE	1-phase
	FREQUENCY AND VOLT	220-240V~ 50Hz
CIRCUIT BREAKER/FUSE(A)		15/15
INDOOR UNIT POWER WIRING(mm ²)	BELOW 20m	Twisted pair wire 2.5mm ²
	BELOW 50m	Twisted pair wire 6mm ²
GROUND WIRING(mm ²)		2.5mm ²

Wiring figure

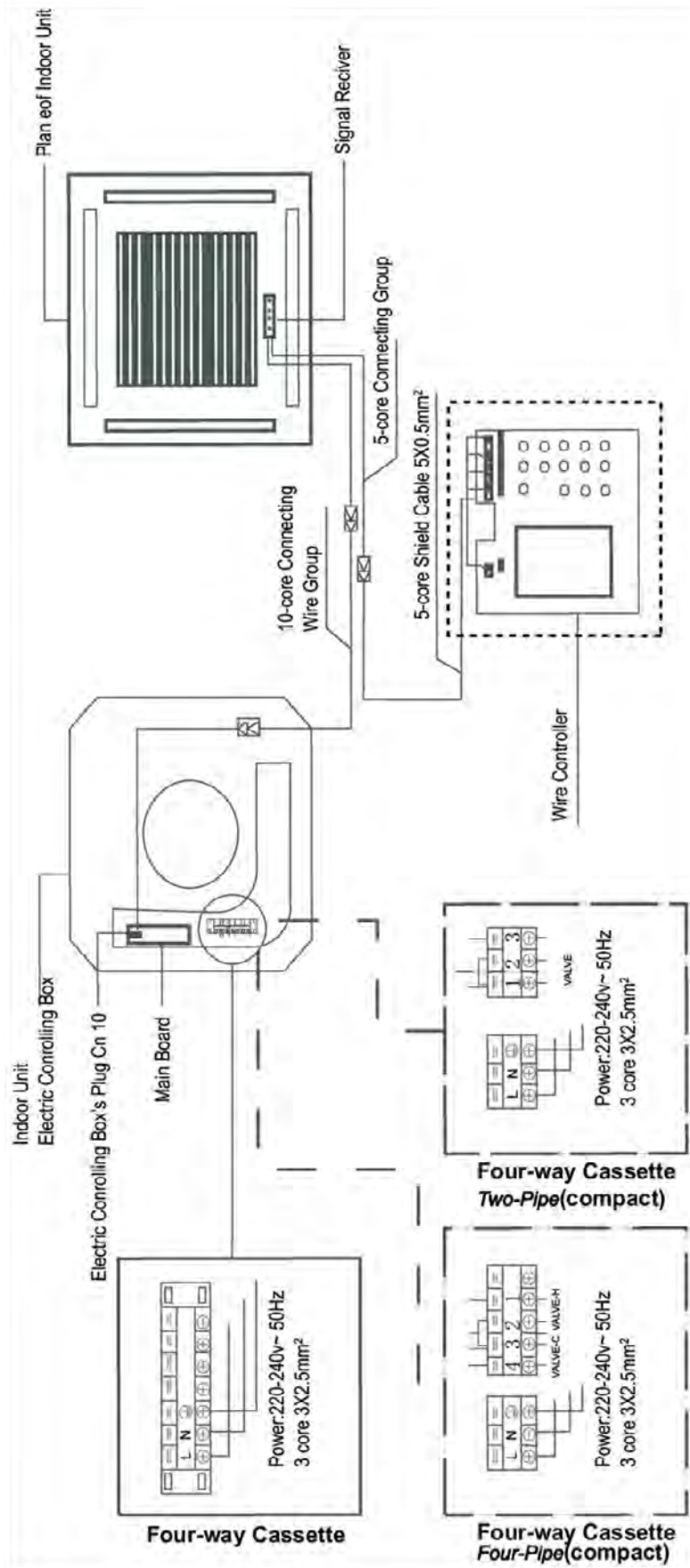

Note: If the supply cord is damaged, it must be replaced by the manufacturer or its service agent or a similarly qualified person in order to avoid a hazard.

1.8 Test operation

- The test operation must be carried out after the entire installation has been completed.
- Please confirm the following points before the test operation:
 - The indoor unit and outdoor unit are installed properly.
 - Tubing and wiring are correctly completed.
 - The water pipe system is leakage-checked. The drainage is unimpeded.
 - The heating insulation works well.
 - The ground wiring is connected correctly.
 - The length of the tubing has been recorded.
 - The power voltage fits the rated voltage of the air conditioner.
 - There is no obstacle at the outlet and inlet of the outdoor and indoor units.
 - The air conditioner is pre-heated by turning on the power.
- According to the user's requirement, install the remote controller frame where the remote controller's signal can reach the indoor unit smoothly.
- Test operation

Set the air conditioner under the mode of "COOLING" with the remote controller, and check the following points. If there is any malfunction, please resolve it according to the chapter "Troubleshooting" in the "Owner's Manual".

- Whether the switch on the remote controller works well.
- Whether the buttons on the remote controller works well.
- Whether the air flow louver moves normally.
- Whether the room temperature is adjusted well.
- Whether the indicator lights normally.
- Whether the temporary buttons works well.
- Whether the drainage is normal.
- Whether there is vibration or abnormal noise during operation.
- Whether the air conditioner heats well in the case of the HEATING/COOLING type.

Caution: A protection feature prevents the air conditioner from being activated for approximately 3 minutes when it is restarted immediately after shut off.