

FOUR-WAY CASSETE VRF INDOOR UNIT



TRUST AIR CONDITIONING EQUIPMENT CO.
Prepared By: Engineering & R & D Department.

INSTALLATION MANUAL

Four-way Cassette Type

Digital Scroll and DC/AC Inverter Commercial Air-conditioner

The Digital Scroll and DC/AC Inverter share the same indoor units.

Thank you very much for purchasing our air conditioner,
please read this manual carefully and keep it for future reference.

1. PRECAUTIONS.....	1
2. INSTALLATION INFORMATION.....	2
3. ATTACHED FITTINGS AND LOCAL PURCHASED COMPONENTS	3
4. INSTALLATION.....	4
5. LAYOUT THE DRAIN PIPE.....	10
6. INSTALL THE CONNECTING PIPE.....	11
7. WIRING.....	13
8. CONTROL OPERATION.....	15
9. TEST OPERATION.....	17

1. PRECAUTIONS

- Be sure to be in conformity with the local, national and international laws and regulations.
- Read "PRECAUTIONS" carefully before installation.
- The following precautions include important safety items. Observe them and never forget.
- Keep this manual with the owner's manual in a handy place for future reference.

The safety precautions listed here are divided into two categories. In either case, important safety information is listed which must be read carefully.



WARNING

Failure to observe a warning may result in death.



CAUTION

Failure to observe a caution may result in injury or damage to the equipment.

After completing the installation, make sure that the unit operates properly during the start-up operation. Please instruct the customer on how to operate the unit and keep it maintained. Also, inform customers that they should store this installation manual along with the owner's manual for future reference.



WARNING

Be sure only trained and qualified service personnel to install, repair or service the equipment. Installation must be performed in accordance with the requirements of NEC and CEC by authorized personnel only.

Improper installation, repair, and maintenance may result in electric shocks, short-circuit, leaks, fire or other damage to the equipment.

Install according to this installation instructions strictly. If installation is defective, it will cause water leakage, electrical shock fire.

When installing the unit in a small room, take measures against to keep refrigerant concentration from exceeding allowable safety limits in the event of refrigerant leakage. Contact the place of purchase for more information. Excessive refrigerant in a closed ambient can lead to oxygen deficiency.

Use the attached accessories parts and specified parts for installation.

Otherwise, it will cause the set to fall, water leakage, electrical shock fire.

Install at a strong and firm location which is able to withstand the set's weight.

If the strength is not enough or installation is not properly done, the set will drop to cause injury.

The appliance must be installed 2.3m above floor.

The appliance shall not be installed in the laundry.

Before obtaining access to terminals, all supply circuits must be disconnected.

The appliance must be positioned so that the plug is accessible.

The enclosure of the appliance shall be marked by word, or by symbols, with the direction of the fluid flow.

For electrical work, follow the local national wiring standard, regulation and this installation instructions. An independent circuit and single outlet must be used.

If electrical circuit capacity is not enough or defect in electrical work, it will cause electrical shock fire.

Use the specified cable and connect tightly and clamp the cable so that no external force will be acted on the terminal.

If connection or fixing is not perfect, it will cause heat-up or fire at the connection.

Wiring routing must be properly arranged so that control board cover is fixed properly.

If control board cover is not fixed perfectly, it will cause heat-up at connection point of terminal, fire or electrical shock.

If the supply cord is damaged, it must be replaced by the manufacture or its service agent or similarly qualified person in order to avoid a hazard.

An all-pole disconnection switch having a contract separation of at least 3mm in a poles should be connected in fixed wiring.

When carrying out piping connection, take care not to let air substances go into refrigeration cycle.

Otherwise, it will cause lower capacity, abnormal high pressure in the refrigeration cycle, explosion and injury.

Do not modify the length of the power supply cord or use of extension cord, and do not share the single outlet with other electrical appliances.

Otherwise, it will cause fire or electrical shock.

Carry out the specified installation work after taking into account strong winds, typhoons or earthquakes.

Improper installation work may result in the equipment falling and causing accidents.

If the refrigerant leaks during installation, ventilate the area immediately.

Toxic gas may be produced if the refrigerant comes into the place contacting with fire.

After completing the installation work, check that the refrigerant does not leak.

Toxic gas may be produced if the refrigerant leaks into the room and comes into contact with a source of fire, such as a fan heater, stove or cooker.

The appliance shall be installed in accordance with national wiring regulations.

The power cord type designation is H05RN-R/H07RN-F or above.



CAUTION

Ground the air conditioner.

Do not connect the ground wire to gas or water pipes, lightning rod or a telephone ground wire. Incomplete grounding may result in electric shocks.

Be sure to install an earth leakage breaker.

Failure to install an earth leakage breaker may result in electric shocks.

Connect the outdoor unit wires, then connect the indoor unit wires.

You are not allowed to connect the air conditioner with the power source until wiring and piping the air conditioner is done.

While following the instructions in this installation manual, install drain piping in order to ensure proper drainage and insulate piping in order to prevent condensation.

Improper drain piping may result in water leakage and property damage.

Install the indoor and outdoor units, power supply wiring and connecting wires at least 1 meter away from televisions or radios in order to prevent image interference or noise.

Depending on the radio waves, a distance of 1 meter may not be sufficient enough to eliminate the noise.

The appliance is not intended for use by young children or infirm persons without supervision.

Young children should be supervised to ensure that they do not play with the appliance.

Don't install the air conditioner in the following locations:

- There is petrolatum existing.
- There is salty air surrounding (near the coast).
- There is caustic gas (the sulfide, for example) existing in the air (near a hot spring).
- The volt vibrates violently (in the factories).
- In buses or cabinets.
- In kitchen where it is full of oil gas.
- The appliance shall not be installed in the laundry.
- There is strong electromagnetic wave existing.
- There are inflammable materials or gas.
- There is acid or alkaline liquid evaporating.
- Avoid installing it in a narrow space which has a high requirement to noise.
- Other special conditions.

2. INSTALLATION INFORMATION

- **To install properly, please read this "installation manual" at first.**
 - **The air conditioner must be installed by qualified persons.**
 - **When installing the indoor unit or its tubing, please follow this manual as strictly as possible.**
 - **If the air conditioner is installed on a metal part of the building, it must be electrically insulated according to the relevant standards to electrical appliances.**
 - **When all the installation work is finished, please turn on the power only after a thorough check.**
 - **Regret for no further announcement if there is any change of this manual caused by product improvement.**
-

INSTALLATION ORDER

- Select the location;
- Install the indoor unit;
- Install the outdoor unit;
- Install the connecting pipe ;
- Connect the drain pipe;
- Wiring;
- Test operation.

3. ATTACHED FITTINGS AND LOCAL PURCHASED COMPONENTS

Please check whether the following fittings are of full scope. If there are some spare fittings , please restore them carefully.

Table: 3-1 《ATTACHED FITTINGS》













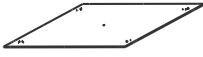











	NAME	SHAPE	QUANTITY
INSTALLATION FITTINGS	1.Nut		8
	2.Washer		8
	3. Installation paper board		1
	4. Bolt M6		4
	5.Electric throttle (That have been installed at the unit)		1
Tubing & Fittings	6. Connective pipe for restriction assembly		1
	7. Soundproof / insulation sheath		2
	8. Sponge I (250*250*10)		1
	9. Sponge II (60*100*5)		1
Drainpipe Fittings	10. Out-let pipe sheath		1
	11. Out-let pipe clasp		1
	12. Tightening band		5
	13.Flexible hose tube		1
Signal line	14.Signal line		1
Remote controller & Its Frame	15. Remote controller		1
	16. Frame		1
	17. Alkaline dry batteries (AM4)		2
	18. Remote contronller owner's manual		1
Others	19. Installation manual		1
	20. Copper(Use for pipe connection of engineering installation)		1

Table: 3-2 《LOCAL PURCHASED COMPONENTS》

NAME	SHAPE	SPECIFICATION	QUANTITY	REMARK
Copper pipe		Liquid side pipe	Select according to the actual needs	Use for connecting the indoor unit refrigerant system, suggest to use flexible copper pipe (T2M)
		Air side pipe		
		Refer to Table: 6-1,Table: 6-1		
PVC pipe		external diameter about 37~39mm, inner diameter is 32mm	Select according to the actual needs	Use for draining the water in the indoor unit
Heat insulation casing pipe		Inner diameter corresponds with the copper pipe and PVC pipe, the thickness should be 10mm (above), it should be thicker when in the close humid area.	Select according to the actual needs	Use for preventing the condensate water
Expansible hook		M10	4	Use for the installation of the indoor unit, please purchase from the market
Installation hook		M10	4	Use for the installation of the indoor unit, please purchase from the market

4. INSTALLATION

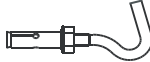
4.1 Installation place

(Refer to Fig. 4-1, Fig. 4-2, Fig. 4-3 and Table: 4-1 for specification.)

The indoor unit should be installed in a location that meets the following requirements:

- Avoid installing it in a narrow space which has a high requirement to noise.
- The ceiling is horizontal, and its structure can endure the weight of the indoor unit.
- The outlet and the inlet are not impeded, and the influence of external air is the least.
- The air flow can reach throughout the room.
- The connecting pipe and drainpipe could be extracted out easily.
- There is no direct radiation from heaters.
- Don't install it in a place whose air contains much salt. If this can't be avoided, choose a anticorrosive model.

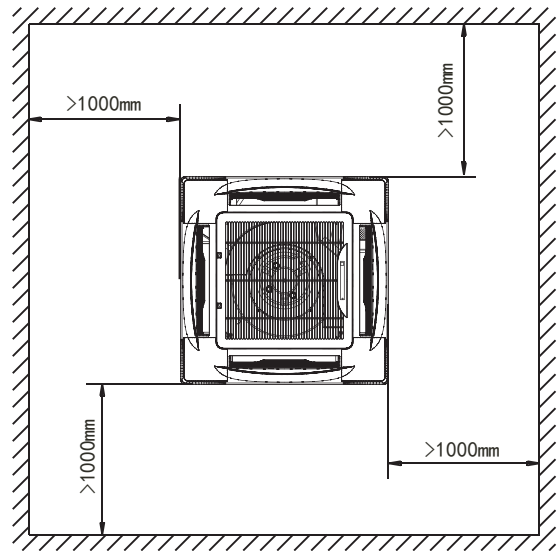

Fig. 4-2



CAUTION

Installing the equipment in any of the following places may lead to faults of the equipment (if that is inevitable, consult the supplier):

- The site contains mineral oils such as cutting lubricant.
- Seaside where the air contains much salt.
- Hotpring area where corrosive gases exist, e.g., sulfide gas.
- Factories where the supply voltage fluctuates seriously.
- Inside a car or cabin.
- Place like kitchen where oil permeates.
- Place where strong electromagnetic waves exist.
- Place where flammable gases or materials exist.
- Place where acid or alkali gases evaporate.
- Other special environments.

4.2 Air supply direction

To select the following air supply directions base on your room sharp and the unit installed site:

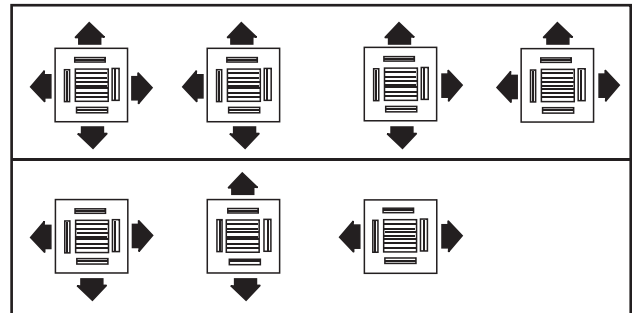

Fig. 4-3

1. Once changing the air supply direction, please replace the wind shield materials. For details of wind shield materials please consult our dealer.
2. Such as the above figure of air supply direction, before install wind shield material, please remove the panel firstly, and then insert the wing shield panel into air outlet of main body.

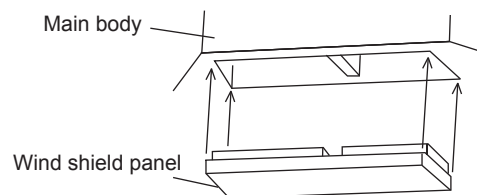

Fig. 4-4

3. As for operating the electric heater and additional purchased humidifier at the same time, to be on safe side, don't alter the air supply direction, and shall employ four-way air supply type to operation.

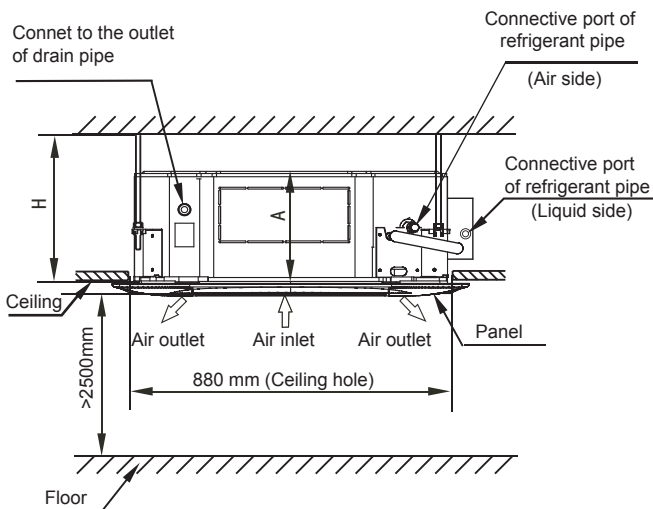

Fig. 4-1

Table: 4-1

Indoor unit	A (mm)	H (mm)
≤8000W	230	≥260
≥9000W	300	≥330



WARNING

- Install the unit at a site with sufficient strength to supporting the weight of the unit.
- Insufficient supporting strength would fall-down the unit and cause human physical injury.
- Special installation to prevent the unit be blown down by strong wind and be shocked by earthquake. Failure installation would cause fall-down accident.

4.3 Install the main body

■ The existing ceiling (to be horizontal)

- 1 Cut a quadrangular hole of 880x880mm in the ceiling according to the shape of the installation paper board.
(refer to Fig. 4-4, Fig. 4-6 and Fig. 4-7)
 - The center of the hole should be at the same position of that of the air conditioner body.
 - Determine the lengths and outlets of the connecting pipe, drainpipe and cables.
 - To balance the ceiling and to avoid vibration, please enforce the ceiling when necessary.
- 2 Select the position of installation hooks according to the hook holes on the installation board.
 - Drill four holes of ϕ 12mm, 45~50mm deep at the selected positions on the ceiling. Then embed the expansible hooks .
 - Face the concave side of the installation hooks toward the expansible hooks. Determine the length of the installation hooks from the height of ceiling, then cut off the unnecessary part.
 - If the ceiling is extremely high, please determine the length of the installation hook according to facts.
- 3 Adjust the hexangular nuts on the four installation hooks evenly, to ensure the balance of the body.
 - If the drainpipe is awry, leakage will be caused by the malfunction of the water-level switch.
 - Adjust the position to ensure the gaps between the body and the four sides of ceiling are even. The body's lower part should sink into the ceiling for 10~12 mm (refer to Fig. 4-9).

Locate the air conditioner firmly by wrenching the nuts after

 - having adjusted the body's position well.(refer to Fig. 4-10)

■ New built houses and ceilings

- 1 In the case of new built house, the hook can be embedded in advance (refer to 2 mentioned above). But it should be strong enough to bear the indoor unit and will not become loose because of concrete shrinking.
- 2 After installing the body, please fasten the installation paper board onto the air conditioner with bolts(M6X12) to determine in advance the sizes and positions of the hole opening on ceiling.(refer to Fig. 4-5)
 - Please first guarantee the flatness and horizontal of ceiling when installing it.
 - Refer to 1 mentioned above for others.

- 3 Refer to 3 above for installation.
- 4 Remove the installation paper board.

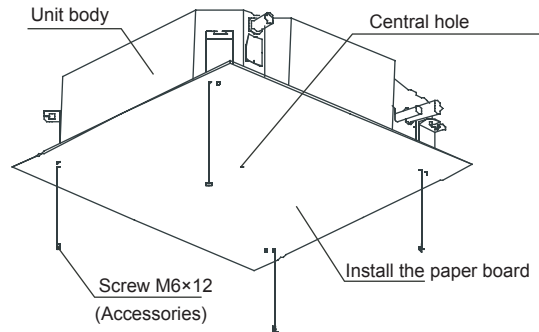

Fig. 4-5



CAUTION

- Before install the indoor unit, please remove the buffer between in fan and flared mouth firstly. Otherwise, running operation would damage the fan motor (See Fig. 4-6).
- Ensure that the indoor unit is placed horizontally.
- During connect the electrical restriction assembly to pipes of indoor and outdoor units, please wrench it by two spanners to avoid pipe be cracked.

The length of U-shaped lugs that come from the throttle cabinet should be adjusted to the proper position while piping

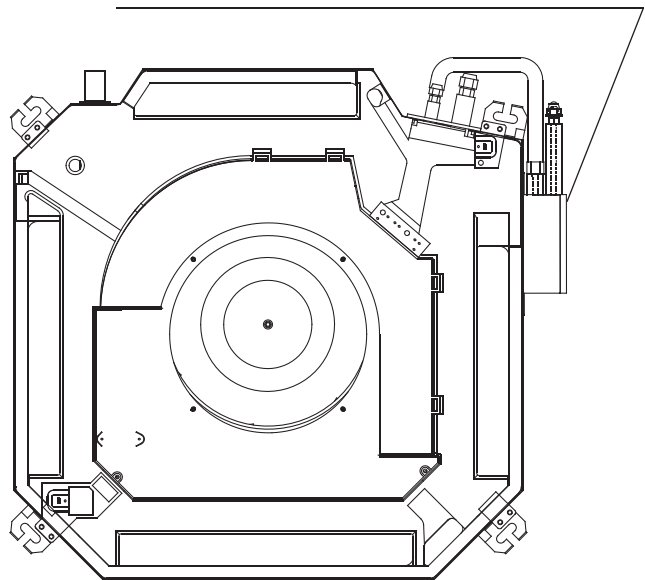

Fig. 4-6

FIGURES

(Unit:mm)

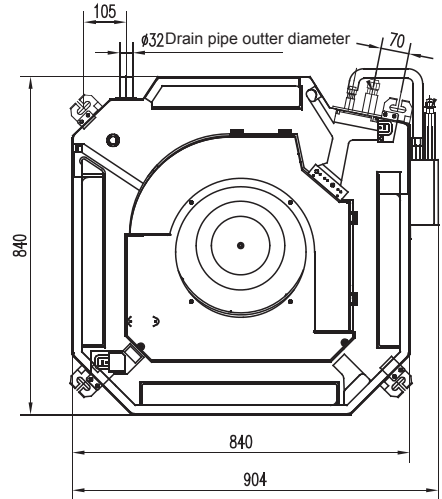
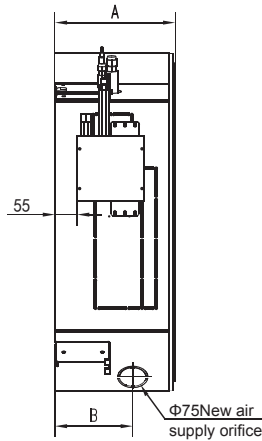
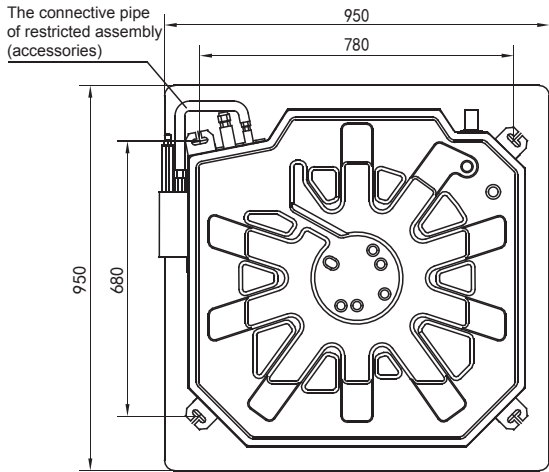

Fig. 4-7

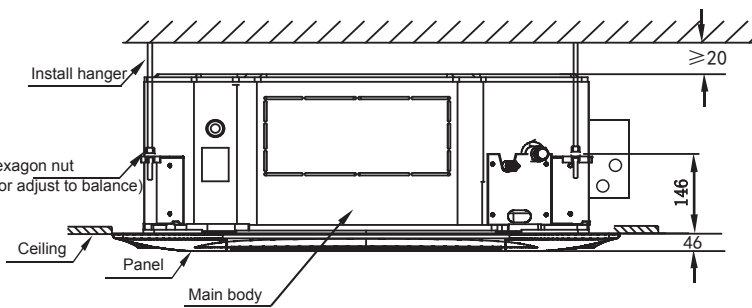

Fig. 4-8

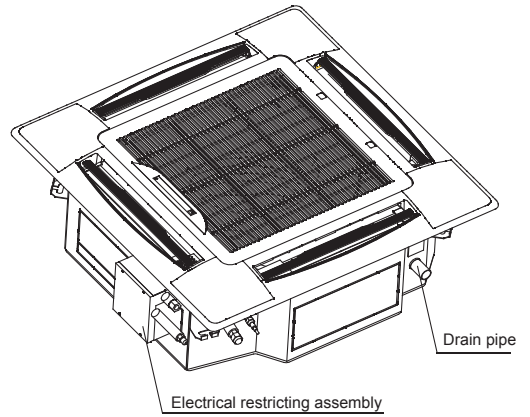

Fig. 4-9

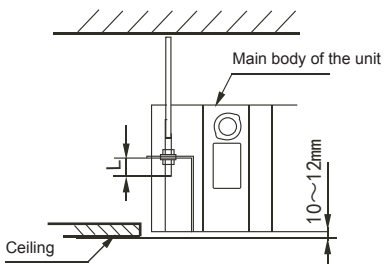

Fig. 4-10

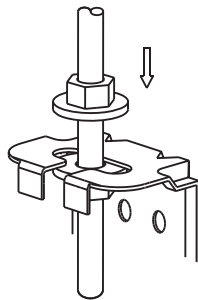

Fig. 4-11

Table: 4-2

Indoor unit model	A (mm)	B (mm)
≤8000W	230	126
≥9000W	300	197



NOTE

All the pictures in this manual are for explanation purpose only. They may be slightly different from the air conditioner you purchased (depend on model). The actual shape shall prevail.

4.4 Procedure of installing the pendant bolt

Base on the unit structure, please set the screw-pitch according to the size of the following figures:

Table: 4-3

Wooden structure
Put rectangular sticks across the beams, and set pendant bolts.

Old concrete roughcast
Use embedded bolts and embedded pulling plugs.

Table: 4-4

Steel beam and girder structure
Set and use supportive angle steel.

New concrete roughcast
Set it with embedded bushes or embedded bolts.

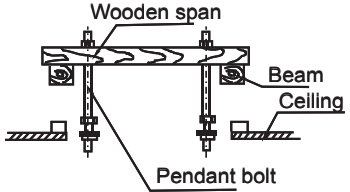
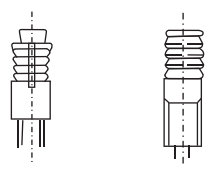
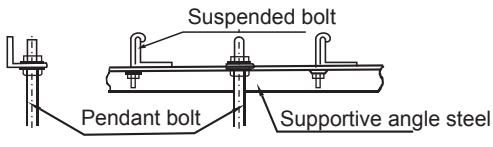
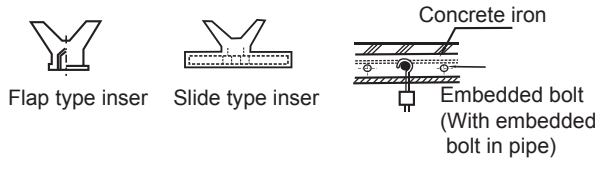

CAUTION

- The bolt material is the high quality carbon steel (galvanized or covered other rust preventive materials on the surface) or rustless steel.
- The ceiling rust prevention measure is conducted according to actual construction, for detail method please consult building engineer.
- Suspending bolts must be fixed, the fixing method as per to the actual situation.

4.5 Install the panel



CAUTION

- Never put the panel face down on floor or against the wall, or on bulgy objects.
- Never crash or strike it.

1. Remove the air-in grill.

1) Slide two grill switches toward the middle at the same time, and then pull them up. (Refer to Fig.4-12)

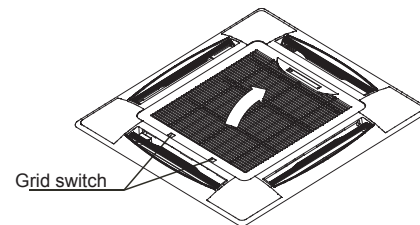

Fig.4-12

2) Draw the grill up to an angle of about 45°, and remove it. (Refer to Fig.4-13)

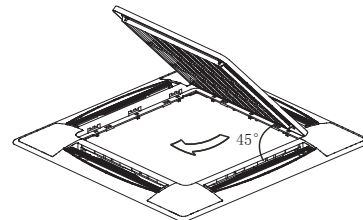

Fig.4-13

2. Remove the installation covers at the four corners.

Wrench off the bolts, loose the rope of the installation covers, and remove them. (Refer to Fig.4-14)

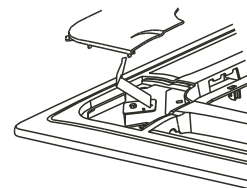

fig.4-14

3. Install the panel

- 1) The part of panel that marked "PIPING SIDE" and "DRAIN SIDE" shall be aligned to piping outlet and drainpipe outlet from main body.
- 2) Fix hooks of the panel at swing motor and its opposite sides to the hooks of corresponding water receiver. (Refer to Fig.4-15 a) Then hang the other two panel hooks onto corresponding hangers of the body. (Refer to Fig.4-15 b)
- 3) Insert the conducting wire of sway motor into the conducting slot inside of panel, and then connect the sway motor terminals holder to the terminal in main electrical control box.
- 4) Adjust the four panel hook screws to keep the panel horizontal, and screw them up to the ceiling evenly. (Refer to Fig.4-15 c)
- 5) Regulate the panel in the direction of the arrow in fig.4-14 d slightly to fit the panel's center to the center of the ceiling's opening. Guarantee that hooks of four corners are fixed well.
- 6) Keep fastening the screws under the panel hooks, until the thickness of the sponge between the body and the panel's outlet has been reduced to about 4~6mm. The edge of the panel should contact with the ceiling well. (Refer to Fig.4-16)

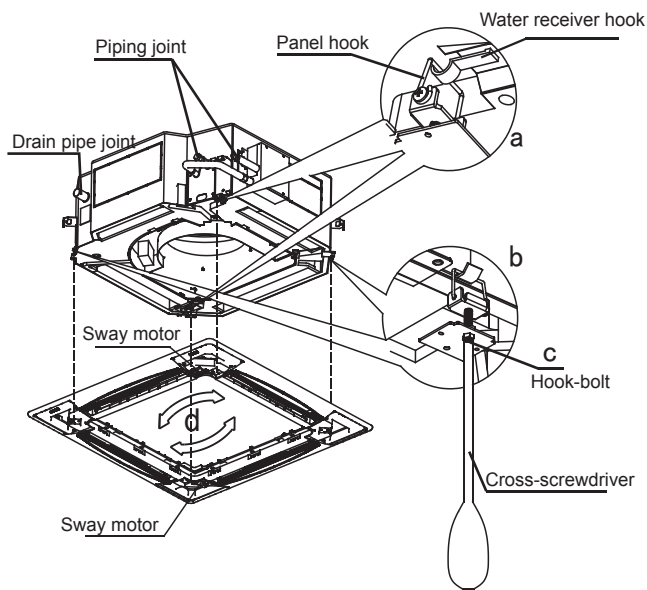

Fig.4-15

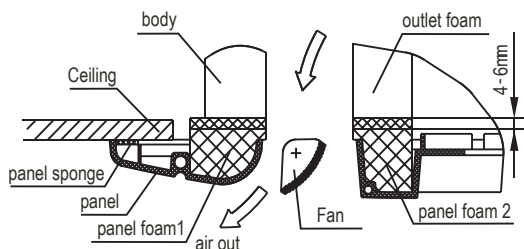

Fig.4-16



CAUTION

- 1) The salient of plastic cap in sway motor shall be inserted in the notch of the water outflow pipe seal board.
- 2) Do not coil the wiring of the swing motor into the seal sponge.
- 3) Malfunction described in Fig.4-17 can be caused by inappropriate tightness the screw.

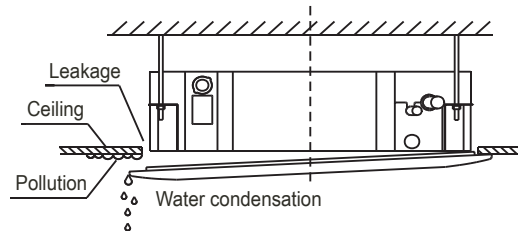

Fig.4-17

- 4) If the gap between the panel and ceiling still exists after fastening the screws, the height of the indoor unit should be modified again. (Refer to Fig.4-18)

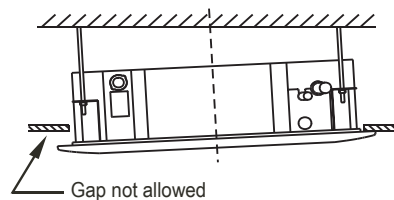

Fig.4-18

- 5) You can modify the height of the indoor unit through the openings on the panel's four corners, if the lift of the indoor unit and the drainpipe is not influenced (refer to Fig.4-19).

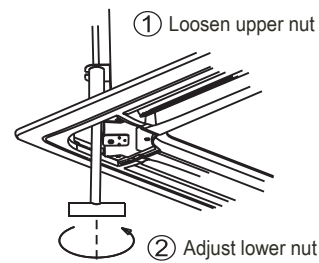

Fig.4-19

4. Hang the air-in grill to the panel, then connect the lead terminator of the swing motor and that of the control box with corresponding terminators on the body respectively.

5. Relocate the air-in grill in the procedure of reversed order.

6. Relocate the installation cover.

- 1) Fasten the rope of installation cover on the bolt of the installation cover. (Refer to Fig.4-20)
- 2) Press the installation cover into the panel slightly. (Refer to fig.4-21)

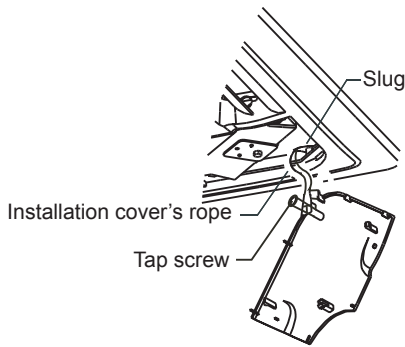

Fig. 4-20

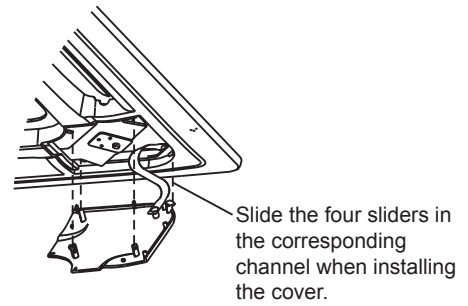

Fig. 4-21

4.6 Install the distribution duct

Conditioned air can be distributed by means of a distribution duct.

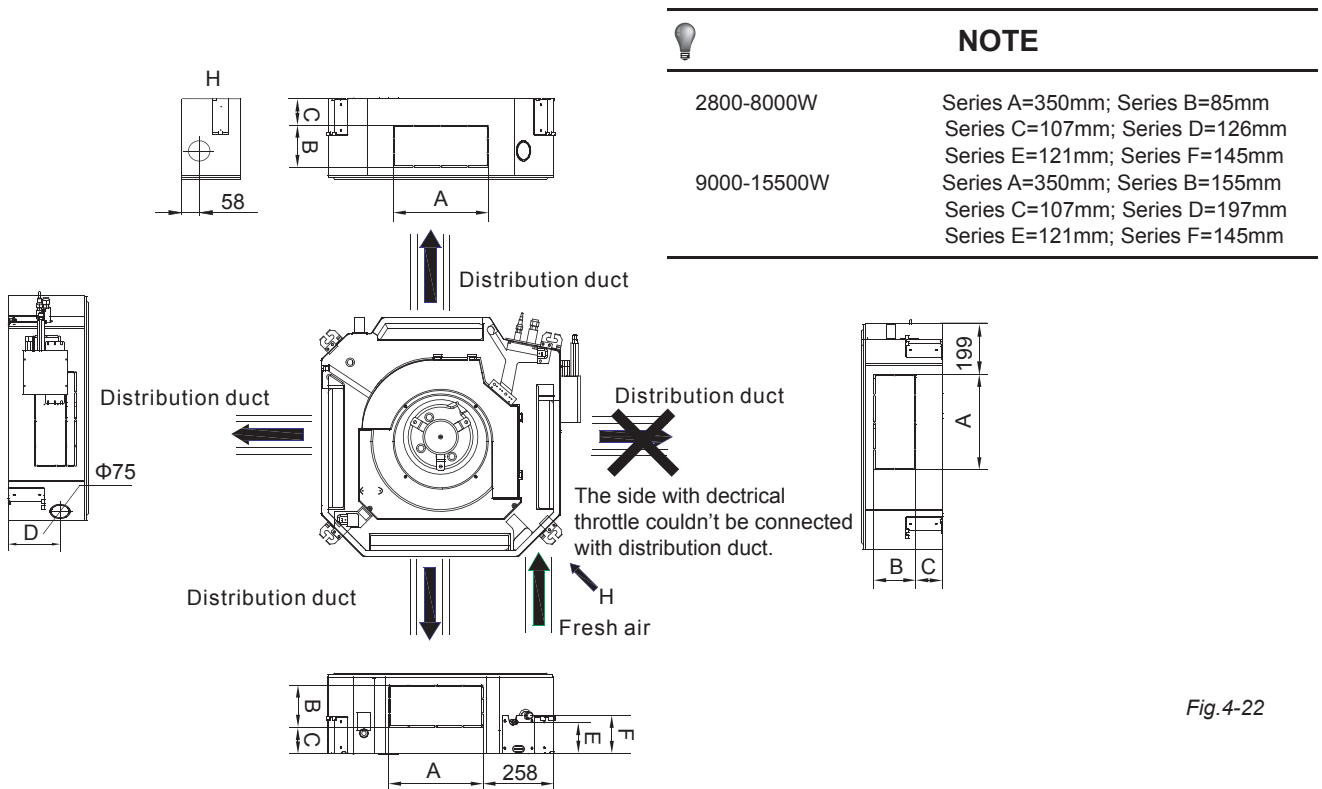

Fig. 4-22

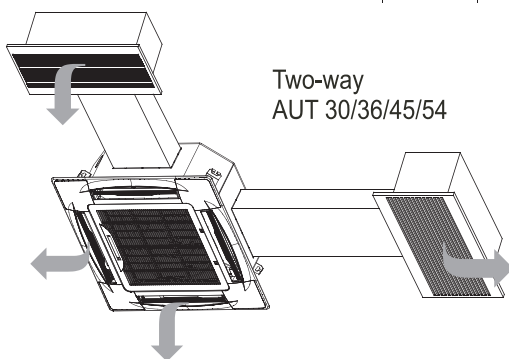

Fig. 4-23

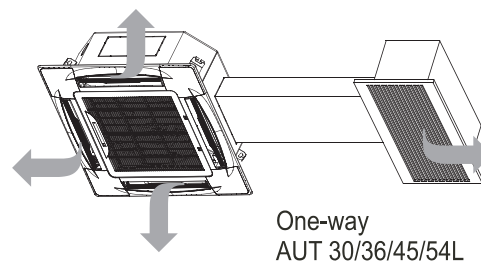

Fig. 4-24

- In case of one duct connection
 - The air volume in duct is around 300-360m³/h for 5600W to 8000W unit
 - The air volume in duct is around 400-640m³/h for 9000W to 15500W unit
 - The max. length of duct is 2m
 - The original air outlet with the same direction of duct should be sealed
- In case of two duct connection
 - The air volume in one duct is around 200-260m³/h for 5600W to 8000W unit
 - The air volume in one duct is around 300-500m³/h for 9000W to 15500W unit
 - The max. length of duct is 1.5m for one duct
 - The original air outlet with the same direction of duct should be sealed

5. LAYOUT THE DRAIN PIPE

5.1 Install the drain pipe of indoor unit

1) The drainpipe can use PVC pipe (external diameter about 37~39mm, inner diameter is 32mm).

2) Joint drainpipe connector to the end side of water pumping pipe, and fix drainpipe together with water outflow pipe and thermal insulation tube by clasp of water outflow pipe (attached).



CAUTION

Don't use forcing strength to crack the water-pumping pipe.

3) Water-pumping pipe and drainpipe from main body must be wrapped by insulation tube evenly, and bound by tighten band for obstructing air getting in and coagulation.

4) Prevent from water backflow into unit inside during shutdown, the drain pipe shall place down side and drain water to outdoor (drain side), the gradient of the drain pipe should be higher than (1/100), without salient and water remain. (Refer to Fig. 5-1 a)

5) When connecting drainpipe, don't drag the pipe that would pull the main unit. For this, please arrange bearing points every 0.8 to 1.0 meter to avoid pipe be bended (See Fig. 5-1 b).

6) When connect a lengthen drainpipe, apply protective tube to wrap its indoor parts for ensuring the lengthen part connected tightly.

7) In case the drainpipe outlet is higher than pumping connective pipe of the main body, the drainpipe must be arranged upwards vertically by using connective assembly of the water outlet for vertical bending, and the height of the drainpipe shall set to the defrosting pan surface no more than 1000mm, otherwise, too much backflow while shutdown would leads to overflow (Refer to Fig. 5-2).

8) Base on the actual requirement to bend piping, and use connective assembly of water outlet in terminal box for pipe layout.



CAUTION

The joints in drain system must be sealed to avoid water leakage.

9) The height from floor to the end of drainpipe or the bottom of drain slot must more than 50 mm. Don't immerse the end of drainpipe or the bottom of drain slot into water. When drain condensate liquid to raceway, please bend the drainpipe to a U-shaped hydroseal for avoiding stench transmitted by drainpipe to indoor.

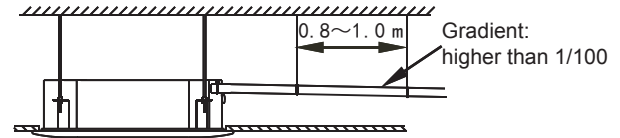

a ○

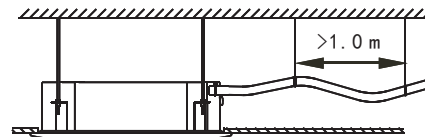

b ✗

Fig. 5-1

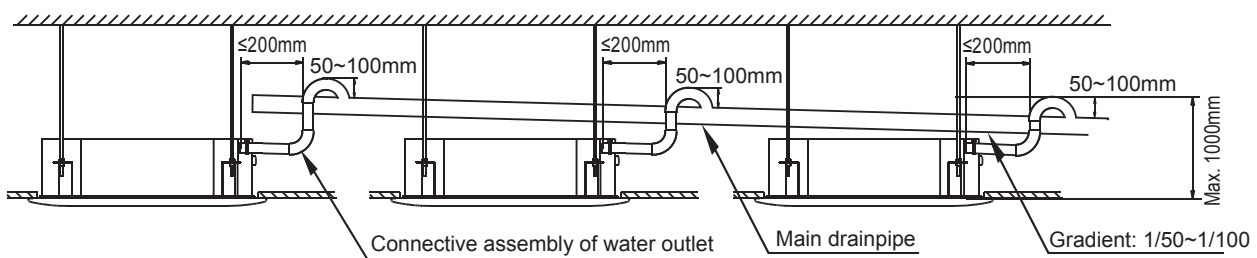

Drainpipes from many units confluent water to main drainpipe and discharge to cloacae.

Fig. 5-2

5.2 Drain test

1. Before testing, please ensure that water could be drained fluently, and check all joints are sealed.
2. Drain test shall be processed before construct ceiling for a new house.
 - 1) Remove water finding cap, charge 2000ml water into defrosting pan through water finding orifice by water charged pipe. (See Fig. 5-3)
 - 2) Power on the unit and run cooling operation. Check that the operation noise of water drain pump is normal and water discharge fluently (depend on the length of drain pipe, water will drain delay about 1 minute), then check whether joints are leakage.

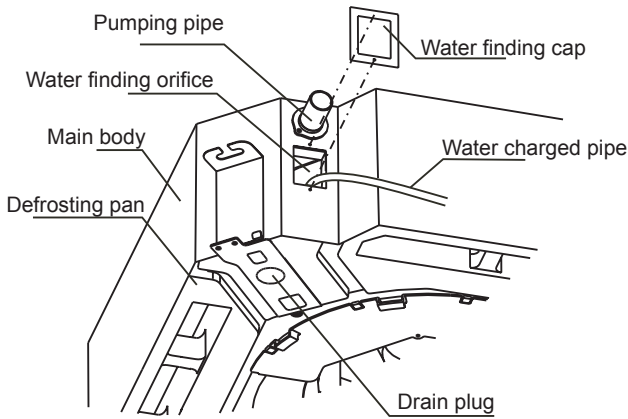

Fig. 5-3



CAUTION

In case malfunction occur, problems settlement shall be taken as soon as possible.

- 3) Stop the air conditioner, detect whether exists abnormal problems after 3 minutes. Irrationally set of the drainpipe would lead to water backflow and make alarm director in control box flashing, or even cause water overflow from defrosting tray.
- 4) Level alarm will flash, if water were continually charged and over to alarm level. Please check whether the drain pump operates water discharge at once. In case level were not decreasing under alarm level after 3 minutes, unit would close down. You must cut off power and discharge accumulated water firstly, then the unit could be restarted normally.
- 5) Cut off power, discharge accumulated water, and reset the test cap to its original position.



CAUTION

A drain plug at the bottom of main unit is used for discharging accumulated water in defrosting tray when malfunction occur. During normal operation, please ensure that this plug is stuffed tightly to prevent water leakage.

6. INSTALL THE CONNETING PIPE

6.1 The connective length of indoor and outdoor piping and those height difference requirements.

Connect to different outdoor units with different connective length and height difference requirements. Please refer to Indoor Unit Installation Manual for detail.

6.2 Piping materials and size

- 1) Piping materials: Copper tube special for air conditioner, normally T2M.
- 2) Piping size: Refrigerant is R22, please refer to Table: 6-1; while refrigerant is R410A, please refer to Table: 6-2

Table: 6-1

Indoor unit model	Piping size (mm)	
	Liquid side	Air side
≤3600W	φ 6.4	φ 12.7
4500W~9000W	φ 9.5	φ 15.9
≥10000W	φ 9.5	φ 19.0

Applicable for the models employing R22 refrigerant

Table: 6-2

Indoor unit model	Piping size (mm)	
	Liquid side	Air side
≤4500W	φ 6.4	φ 12.7
≥5600W	φ 9.5	φ 15.9

Applicable for the models employing R410A refrigerant

6.3 Procedure of connecting pipes

1. Measure the required length of the connective pipe, and make the connective pipes in the following procedure. (Refer to Pipeline Connection for details)
 - 1) Connect the indoor unit first, and then connect the outdoor unit.
 - a. The pipe bend should be handled carefully, without damaging the pipe and insulation layer.
 - b. Before screwing up the flared nut, apply refrigerant oil at the outer surface of the pipeline flare and the taper surface of the connection nut. Screw up the nut for 3~4 circles beforehand (see Fig.6-1).

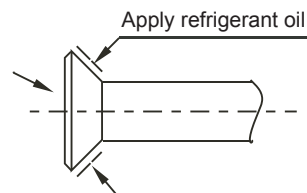

Fig.6-1

- c. When connecting or disconnecting the pipeline, be sure to use two spanners concurrently.
- d. Do not rest the weight of the connective pipe on the adapter of the indoor unit. Too heavy load on the adapter of the indoor unit may deform the pipe and thus affect the cooling/heating effect.

2) The valve of the outdoor unit should be closed completely (as in the factory status). Every time when connecting the pipe, screw off the nut at the valve, and connect the flared pipe (within 5 minutes). If the nut is put away for a long time after being screwed off the valve, dust and other foreign substance may intrude into the pipeline system and lead to fault.

3) After the refrigerant pipe is connected to the indoor and outdoor units, expel air as instructed in the "Expel air" section. After expelling the air, screw up the nut at the maintenance orifice.

a. Precautions for the flexible part of the pipeline
 i. The bend angle shall not exceed 90°. (See Fig. 6-2)

Use a thumb to bend the pipe



Minimum radius 100mm

Fig. 6-2

ii. The bend shall be preferably in the middle of the pipe length, and higher bend radiuses are preferred.
 iii. Do not bend the flexible pipe for over 3 times.

b. Bend the thin-wall connective pipe (See Fig. 6-3)

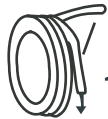

Method of unleashing the spooled pipe
 Straighten the pipe end

Fig. 6-3

i. When bending the pipe, cut out a notch of the desired size at the bend of the adiabatic pipe, and then expose the pipe (wrap the pipe with the wrapping tape after bending it).
 ii. The radio of the elbow pipe should be as large as possible to prevent flattening or crush.
 iii. Use the pipe bender to make close elbow pipe.

c. Use purchased copper pipe

When the copper pipe is purchased from the market, be sure to use the heat insulation materials of the same type (with a thickness of over 9mm).

2. Deploy the pipelines

1) Drill a porthole on the wall, and put the hole sheath and hole cover through the wall.

2) Place the connective pipe together with the indoor & outdoor connection wires. Use wrapping tape to tie them tight. Do not let air penetrate into it lest condensation and drips of moist.

3) Pull the connective wrapped connective pipe from outdoor through the sheath, which gets through the wall, and lead it into the room.

3. Make a vacuum of connective pipeline.

4. After the above steps are completed, the spool of the valve of the outdoor unit should be completely open, and the refrigerant pipeline of the indoor unit and the outdoor unit should be smooth.

5. Use a leak detector or soap water detect leak carefully to prevent leakage.

6. Put on an adiabatic envelope (accessory) at connective pipe adapter of the indoor unit, and wrap it tight with the wrapping tape lest condensate and leakage.

6.4 Pipeline connection

1. Flare

1) Use a pipe cutter to cut off the pipe (See Fig. 6-4)

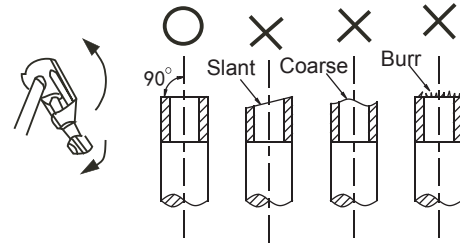

Fig. 6-4

2) Pull the pipe into the rear flare of the connective nut. (Refer to Table: 6-3)

Table: 6-3

Outer diameter (mm)	A (mm)	
	Max.	Min.
φ 6.4	8.7	8.3
φ 9.5	12.4	12.0
φ 12.7	15.8	15.4
φ 15.9	19.0	18.6
φ 19.1	23.3	22.9

2. Tighten the nut

Align with the connective pipe, screw up the connection pipe nut manually, and use a spanner to tighten it as shown in Fig. 6-5.

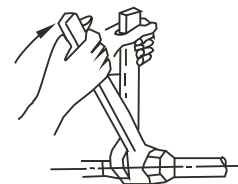

Fig. 6-5



CAUTION

According to the installation conditions, too large torque will damage the flaring, and too small torque will lead to looseness and leakage. Determine the tightening torque by reference to Table: 6-4.

Table: 6-4

Tubing size	Torque
Φ6.4mm	14.2~17.2 N.m (144~176 kgf.cm)
Φ9.5mm	32.7~39.9 N.m (333~407 kgf.cm)
Φ12.7mm	49.5~60.3 N.m (504~616 kgf.cm)
Φ15.9mm	61.8~75.4 N.m (630~770 kgf.cm)
Φ19.1mm	97.2~118.6 N.m (990~1210 kgf.cm)



CAUTION

- Please beware when install connective pipe, do not let any air, dust or other foreign substance invading into system.
- Pipes connection could be conducted after the indoor and outdoor unit are be fixed.
- Connective pipe must keep in dry when installation, do not let water invade in it.
- Connective copper pipe must be wrapped insulation layer (at least 9 mm thickness).
- The temperature of refrigerant circuit will be high, please keep the interconnection cable away from the copper tube

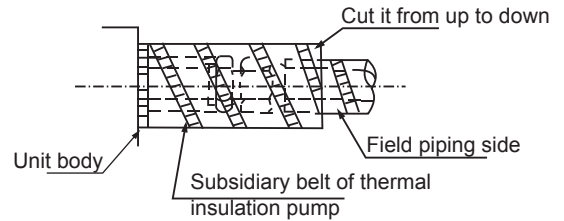

Fig. 6-6

6.5 Air expels

- Apply vacuum pump expels air from refrigerant charging vent of air side in outdoor unit. It is forbidden to apply the refrigerant inside of indoor unit for vacuum air.

6.6 Open valve

Employ a 5 mm hexagon spanner to open the valve spool of indoor and outdoor unit.

6.7 Leak detection

Use soap water to check whether gas leakage exists at the adapters

6.8 Thermal insulation

To process the thermal insulation for air side and liquid side piping. Please insulated the air side and liquid side piping completely, in the reason of during operate cooling mode the ambient temperature is very low.

- 1) Thermal insulation at least 120 C material shall be apply for air side piping.
- 2) Apply attached thermal insulation material to wrap the connective part of indoor piping tightly without gap.

7. WIRING

7.1 Electrical wiring



CAUTION

- 1) Special power shall be applied within rated voltage range. External circuit of this air conditioner must be grounded that means power cable of outdoor unit shall be jointed with external grounding wire reliable.
- 2) Electric wiring must be done by professionals, and wiring according to the wiring label.
- 3) Fixing circuit must be wired with an 11-poledisconnection device at least 3mm switching distance of contact.
- 4) Setting the electrical leakage device according to national regulation.
- 5) Power cables and signal wires shall be arranged orderly and be wired rational without mutual interfere, and connective pipes and body of valves without mutual contact among them.
- 6) The attached connective wire is 10m, provided that the length were not long enough, you must replace it by an appropriate length connective wire in the same specification. In a normal circumstance, it is not allowed to overlapping the two wires, but welded fix and wrapped by insulation adhesive band is except.
- 7) an all-pole disconnection device which has at least 3mm separation distance in all pole and a residual current device(RCD)with the rating of above 10mA shall be incorporated in the fixed wiring according to the national rule.
- 8) All electric wiring is finished, you could input power as long as confirm that all wires connect are correct and fix tightly.

7.2 Power specification

The power cable specifications are as follows. In case power capacity is too low may result in over-heating of piping that would be burned out the unit.

Table 7-1

Item		Power supply of indoor part				Connect wiring		Ground Line
		Power switch		Power cable		Signal wire of indoor and outdoor unit		
		Capacity	Safety fuse	Below 20m	Below 50m	Wire diameter		
2800W~15500W	Power supply: Signal-phase 220-240V~, 50Hz	15A	15A	2X2.5mm ²	2X4.0mm ²	Shielded wire 3X0.75mm ²		Signal line 2.0mm ²
	Power supply: Signal-phase 208-230V~, 60Hz	15A	15A	2X2.5mm ²	2X4.0mm ²	Shielded wire 3X0.75mm ²		Signal line 2.0mm ²

7.3 Indoor unit power

7-3-1 Special power supply is employed for indoor unit that must differ from the outdoor one.

7-3-2 Using the universal indoor power supply, electric leakage protection devices and operating switches for indoor units that connect to a same outdoor unit.

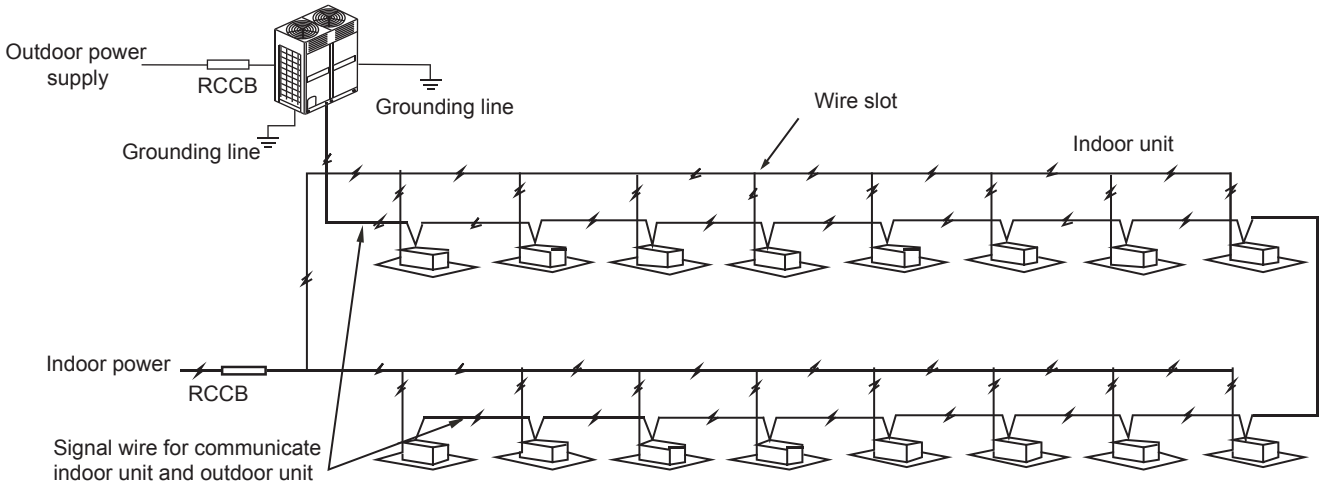

Fig. 7-1

7.4 Signal wire for communicate indoor unit and outdoor unit

This wire must be connected according by terminals numbers. Error connection would lead to unit malfunction.

7.5 Jointing part of wire

Please apply the attached thermal insulation material to seal the jointing part of the pipe. Failure sealing would lead to condensation.

7.6 Wires in panel

Wire the wires holder of swinging motor according to (5.4) Install the panel.

7.7 Setting illustration of terminal holder

Please refer to the nameplate in each indoor unit for connective method.

Signal-phase power supply model

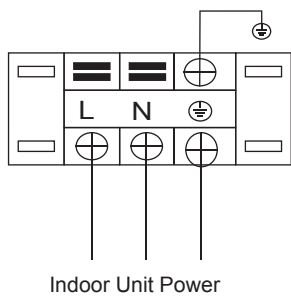

Indoor Unit Power

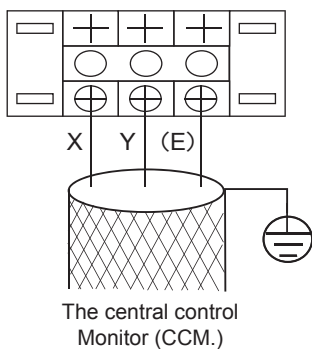

The central control Monitor (CCM.)

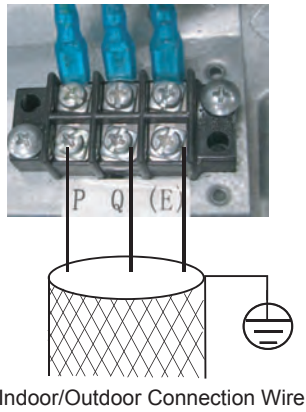
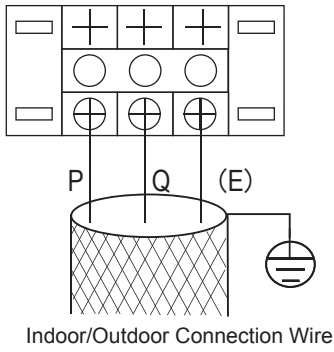

CAUTION

The system together have 64units(0-63),everyone has only system addresscode,If two addresses are the same in one system , the abnormal operation will occur.

Please switch off the power before setting,otherwise the unexpected error will occur.

8.2 Network address set

- 1) Network address is set by communication of indoor and outdoor unit; the address is the same as indoor address, there is no need to set separately.
- 2) The central control of indoor units can be done on outdoor unit, there is no need to control indoor unit separately, for details please refer to V4+ outdoor unit manual.
- 3) For previous control of indoor units, the network can be set by connecting (X,Y,E) terminals, there is no need to set network address. The network can also be set by outer network module and main board (CN20).

8. CONTROL OPERATION

8.1 Horsepower set

Horsepower code

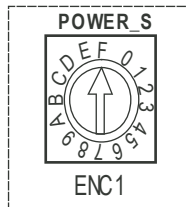

Base on different purposes to setting the switch cords on PC panel of indoor electrical control box. Once finish the setting, please cut off the main power, and then input power again, otherwise, setting function could not work.

Table: 8-1

ENC1	Switch	For setting the cooling output
Note: No one are permitted to alter the cooling output which be set before shipping from factory, except licensed maintain personnel.	Switch cord	Setting the cooling output
	1	2800 W
	2	3600 W
	3	4500 W
	4	5600 W
	5	7100 W
	6	8000 W
	7	9000 W
	8	10000 W
		11200 W
9	14000 W	
A	15500 W	

8.3 Main board Code designation

SW1 definition

ON SW1 1 2 3 4	<ul style="list-style-type: none"> ● 1 means factory test mode ● 0 means add. auto searching mode (default setting) 	ON SW1 1 2 3 4	<ul style="list-style-type: none"> ● 01 means DC fan static pressure is 1 (reserved)
ON SW1 1 2 3 4	<ul style="list-style-type: none"> ● 1 means DC fan Is chosen ● 0 means AC fan Is chosen 	ON SW1 1 2 3 4	<ul style="list-style-type: none"> ● 10 means DC fan static pressure is 2 (reserved)
ON SW1 1 2 3 4	<ul style="list-style-type: none"> ● 00 means DC fan static pressure is 0 (reserved) 	ON SW1 1 2 3 4	<ul style="list-style-type: none"> ● 11 means DC fan static pressure is 3 (reserved)

SW2 definition

ON SW2 1 2 3 4	<ul style="list-style-type: none"> ● 00 means the temperature is 15 degrees when shutting down the unit for cold wind proof. 	ON SW2 1 2 3 4	<ul style="list-style-type: none"> ● 00 means the time of stopping indoor fan is 4 minutes
ON SW2 1 2 3 4	<ul style="list-style-type: none"> ● 01 means the temperature is 20 degrees when shutting down the unit for cold wind proof. 	ON SW2 1 2 3 4	<ul style="list-style-type: none"> ● 01 means the time of stopping indoor fan is 8 minutes
ON SW2 1 2 3 4	<ul style="list-style-type: none"> ● 10 means the temperature is 24 degrees when shutting down the unit for cold wind proof. 	ON SW2 1 2 3 4	<ul style="list-style-type: none"> ● 10 means the time of stopping indoor fan is 12 minutes
ON SW2 1 2 3 4	<ul style="list-style-type: none"> ● 11 means the temperature is 26 degrees when shutting down the unit for cold wind proof. 	ON SW2 1 2 3 4	<ul style="list-style-type: none"> ● 11 means the time of stopping indoor fan is 16 minutes

SW5 definition

ON SW5 1 2	<ul style="list-style-type: none"> ● 00 means temperature compensation is 6 degrees under heating mode 	ON SW5 1 2	<ul style="list-style-type: none"> ● 10 means temperature compensation is 4 degrees under heating mode
ON SW5 1 2	<ul style="list-style-type: none"> ● 01 means temperature compensation is 2 degrees under heating mode 	ON SW5 1 2	<ul style="list-style-type: none"> ● 11 means temperature compensation is 8 degrees under heating mode

SW6 definition

ON SW6 1 2 3	<ul style="list-style-type: none"> ● 1 means old display panel ● 0 means new display panel
ON SW6 1 2 3	<ul style="list-style-type: none"> ● 1 means auto wind under auto mode ● 0 means auto wind under non auto mode
ON SW6 1 2 3	reserved



J1, J2 definition

J1 	J1 no Jumpers means power off memory function
J1 	J1 Jumpers means no power off memory function
J2 	reserved

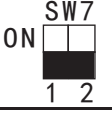
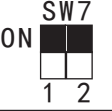
SW7 definition

	Standard configure
	Last one in the network

0/1 definition

	Means 0
	Means 1

h. Whether there is vibration or abnormal noise during operation.

i. Whether the air conditioner heats well in the case of the HEATING/COOLING type.

- 2) The outdoor unit
 - a. Whether there is vibration or abnormal noise during operation.
 - b. Whether the generated wind, noise, or condensed of by the air conditioner have influenced your neighborhood.
 - c. Whether any of the refrigerant is leaked.



CAUTION

A protection feature prevents the air conditioner from being activated for approximately 3 minutes when it is restarted immediately after shut off.

9. TEST OPERATION

- 1 The test operation must be carried out after the entire installation has been completed.
- 2 Please confirm the following points before the test operation:
 - The indoor unit and outdoor unit are installed properly.
 - Tubing and wiring are correctly completed.
 - The refrigerant pipe system is leakage-checked.
 - The drainage is unimpeded.
 - The heating insulation works well.
 - The ground wiring is connected correctly.
 - The length of the tubing and the added stow capacity of the refrigerant have been recorded.
 - The power voltage fits the rated voltage of the air conditioner.
 - There is no obstacle at the outlet and inlet of the outdoor and indoor units.
 - The gas-side and liquid-side stop valves are both opened.
 - The air conditioner is pre-heated by turning on the power.
- 3 According to the user's requirement, install the remote controller frame where the remote controller's signal can reach the indoor unit smoothly.
- 4 Test operation
 - Set the air conditioner under the mode of "COOLING" with the remote controller, and check the following points. If there is any malfunction, please resolve it according to the chapter "Troubleshooting" in the "Owner's Manual".
 - 1) The indoor unit
 - a. Whether the switch on the remote controller works well.
 - b. Whether the buttons on the remote controller works well.
 - c. Whether the air flow louver moves normally.
 - d. Whether the room temperature is adjusted well.
 - e. Whether the indicator lights normally.
 - f. Whether the temporary buttons works well.
 - g. Whether the drainage is normal.



Air Conditioning Systems

Cooling & Heating

TRUST AIR-CONDITIONING EQUIPMENT CO.

Shiraz office: 8 th floor, Alvand Bldg., Dostan St.,
Moaliabad Ave., SHIRAZ, IRAN., Post code: 71877-14446

Tel.: +98-71-36341070

Fax.: +98-71-36341094

Tehran office: No. 19- koohe nour St.- Motahhari St.-

TEHRAN, IRAN., Post code: 15876-73111

Tel.: +98-21-89389

Fax.: +98-21-88541903

Ahwaz office: No. 309- Kaveh St.- AHWAZ, IRAN., Post code: 61939-47911

Tel.: +98-61-32230647-8 E-mail: info@trustacs.com

Fax.: +98-61-32230647 Web site: <http://www.trustacs.com>

برند برتر در اولین جشنواره بین المللی
برترین نام و نشان های تجاری ایران

