

# WALL MOUNTED SPLIT (AB SERIES)

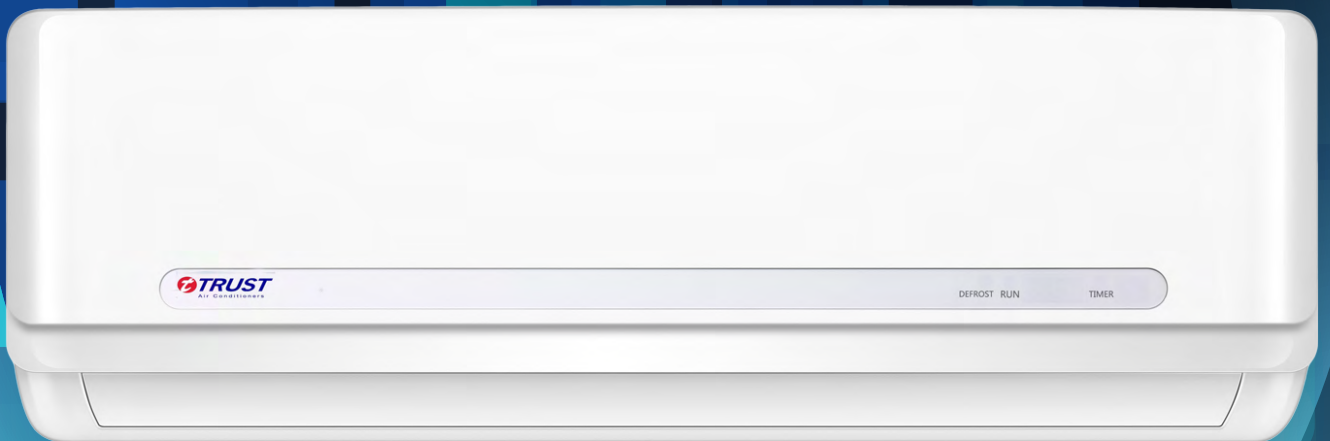

---

TRUST AIR CONDITIONING EQUIPMENT CO.

# CONTENTS

<b>1.Installation Details</b> .....	<b>1</b>
1.1 Wrench torque sheet for installation.....	1
1.2 Connecting the cables.....	1
1.3 Pipe length and the elevation.....	2
1.4 Installation for the first time .....	4
1.5 Adding the refrigerant after running the system for many years.....	5
1.6 Re-installation while the indoor unit need to be repaired.....	6
1.7 Re-installation while the outdoor unit need to be repaired .....	7
<b>2.Operation Characteristics</b> .....	<b>8</b>
<b>3.Electronic function</b> .....	<b>9</b>
3.1 Abbreviation.....	9
3.2 Display function .....	9
3.3 Main Protection .....	10
3.4 Operation Modes and Functions.....	11

توجه:

شرکت تراست حق تغییر مشخصات دستگاه ها را در جهت بهبود و ارتقای  
کیفیت برای خود محفوظ می دارد.

2015

# 1 Installation Details

## 1.1 Wrench torque sheet for installation

Outside diameter		Torque	Additional tightening torque
mm	inch	N.cm	N.cm
Φ6.35	1/4	1500(153kgf.cm)	1600(163kgf.cm)
Φ9.52	3/8	2500(255kgf.cm)	2600(265kgf.cm)
Φ12.7	1/2	3500(357kgf.cm)	3600(367kgf.cm)
Φ15.9	5/8	4500(459kgf.cm)	4700(479kgf.cm)
Φ19	3/4	6500(663kgf.cm)	6700(683kgf.cm)

## 1.2 Connecting the cables

The power cord of connect should be selected according to the following specifications sheet.

Rated current of appliance	Nominal cross-sectional area (mm <sup>2</sup> )
>3 and ≤6	0.75
>6 and ≤10	1
>10 and ≤16	1.5
>16 and ≤25	2.5
>25 and ≤32	4

The cable size and the current of the fuse or switch are determined by the maximum current indicated on the nameplate which located on the side panel of the unit. Please refer to the nameplate before selecting the cable, fuse and switch.

### 1.3 Pipe length and the elevation

The pipe length and refrigerant amount:

Model	Pipe size		Standard length (m)	Max. Elevation B (m)	Max. Length A (m)	Additional refrigerant (g/m)
	Gas	Liquid				
TMSAB09HT1A	3/8" (Φ9.52)	1/4" (Φ6.35)	5	8	20	20
TMSAB12HT1A	1/2" (Φ12.7)	1/4" (Φ6.35)	5	8	20	20
TMSAB18HT1A	1/2" (Φ12.7)	1/4" (Φ6.35)	5	10	25	20
TMSAB24HT1A	5/8" (Φ15.9)	3/8" (Φ9.52)	5	10	25	40
TMSAB30HT1A	5/8" (Φ15.9)	3/8" (Φ9.52)	5	10	25	40
TMSAB36HT1A	5/8" (Φ15.9)	3/8" (Φ9.52)	5	10	25	40

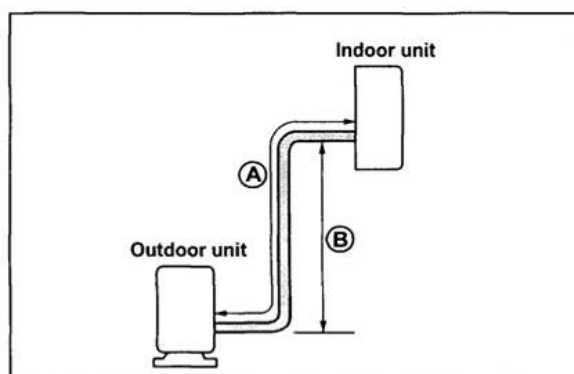

**Caution:**

The capacity test is based on the standard length and the maximum permissible length is based on the system reliability.

## 1.4 Installation for the first time

Air and moisture in the refrigerant system have undesirable effects as below:

- Pressure in the system rises.
- Operating current rises.
- Cooling or heating efficiency drops.
- Moisture in the refrigerant circuit may freeze and block capillary tubing.
- Water may lead to corrosion of parts in the refrigerant system.

Therefore, the indoor units and the pipes between indoor and outdoor units must be leak tested and evacuated to remove gas and moisture from the system.

Gas leak check (Soap water method):

Apply soap water or a liquid neutral detergent on the indoor unit connections or outdoor unit connections by a soft brush to check for leakage of the connecting points of the piping. If bubbles come out, the pipes have leakage.

### 1. Air purging with vacuum pump

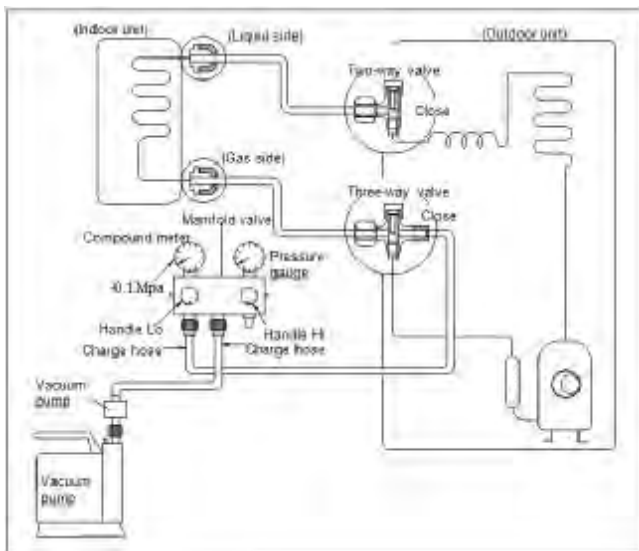

- 1) Completely tighten the flare nuts of the indoor and outdoor units, confirm that both the 2-way and 3-way valves are set to the closed position.
- 2) Connect the charge hose with the push pin of handle lo to the 3-way valves gas service port.
- 3) Connect the charge hose of handle hi connection to the vacuum pump.

- 4) Fully open the handle Lo of the manifold valve.
- 5) Operate the vacuum pump to evacuate.
- 6) Make evacuation for 30 minutes and check whether the compound meter indicates -0.1Mpa. If the meter does not indicate -0.1Mpa after pumping 30 minutes, it should be pumped 20 minutes more. If the pressure can't achieve -0.1Mpa after pumping 50 minutes, please check if there are some leakage points.

Fully close the handle Lo valve of the manifold valve and stop the operation of the vacuum pump. Confirm that the gauge needle does not move (approximately 5 minutes after turning off the vacuum pump).

- 7) Turn the flare nut of the 3-way valves about 45° counterclockwise for 6 or 7seconds after the gas

coming out, then tighten the flare nut again. Make sure the pressure display in the pressure indicator is a little higher than the atmosphere pressure. Then remove the charge hose from the 3 way valve.

- 8) Fully open the 2 way valve and 3 way valve and securely tighten the cap of the 3 way valve.

### 2. Air purging by refrigerant

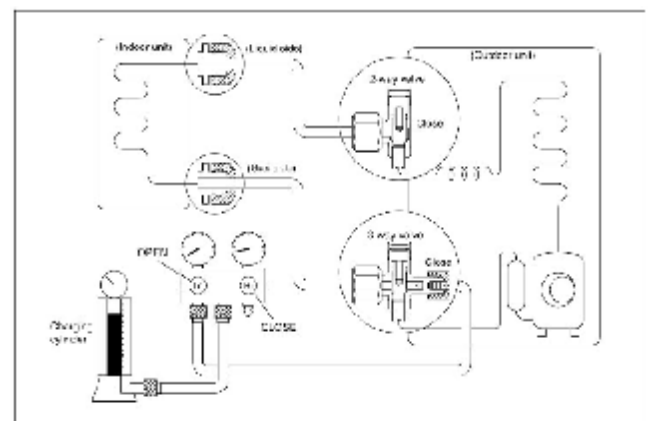

#### Procedure:

- 1). Confirm that both the 2-way and 3-way valves are set to the closed position.
  - 2). Connect the charge set and a charging cylinder to the service port of the 3-way valve.
  - 3). Air purging.
- Open the valves on the charging cylinder and the

charge set. Purge the air by loosening the flare nut on the 2-way valve approximately 45' for 3 seconds then closing it for 1 minute; repeat 3 times.

After purging the air, use a torque wrench to tighten the flare nut on the 2-way valve.

4). Check the gas leakage.

Check the flare connections for gas leakage.

5). Discharge the refrigerant.

Close the valve on the charging cylinder and discharge the refrigerant by loosening the flare nut on the 2-way valve approximately 45' until the gauge indicates 0.3 to 0.5 Mpa.

6). Disconnect the charge set and the charging cylinder, and set the 2-way and 3-way valves to the open position.

Be sure to use a hexagonal wrench to operate the valve stems.

7). Mount the valve stems nuts and the service port cap.

Be sure to use a torque wrench to tighten the service port cap to a torque 18N·m.

Be sure to check the gas leakage.

### 3. Adding the refrigerant if the pipe length >5m

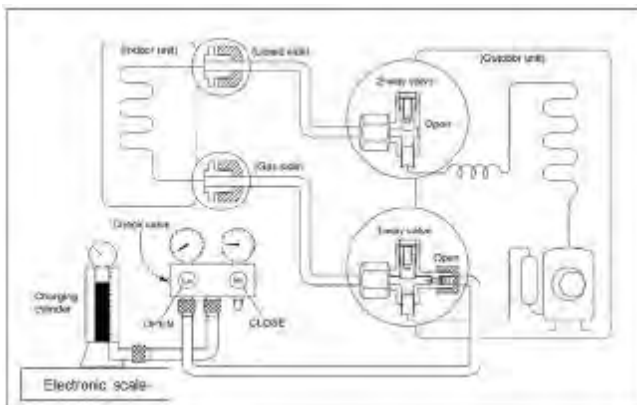

#### Procedure:

1). Connect the charge hose to the charging cylinder, open the 2-way valve and the 3-way valve.

Connect the charge hose which you disconnected from the vacuum pump to the valve at the bottom of the cylinder. If the refrigerant is R410A, make the cylinder bottom up to ensure the liquid charge.

2). Purge the air from the charge hose.

Open the valve at the bottom of the cylinder

and press the check valve on the charge set to purge the air (be careful of the liquid refrigerant).

3) Put the charging cylinder onto the electronic scale and record the weight.

4) Operate the air conditioner at the cooling mode.

5) Open the valves (Low side) on the charge set and charge the system with liquid refrigerant.

6).When the electronic scale displays the proper weight (refer to the table), disconnect the charge hose from the 3-way valve's service port immediately and turn off the air conditioner before disconnecting the hose.

7). Mount the valve stem caps and the service port

Use torque wrench to tighten the service port cap to a torque of 18N.m.

Be sure to check for gas leakage.

### 1.5 Adding the refrigerant after running the system for many years

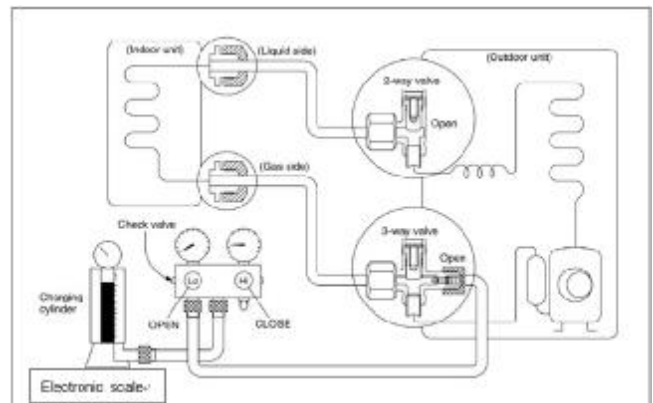

#### Procedure:

1). Connect the charge hose to the 3-way service port, open the 2-way valve and the 3-way valve.

Connect the charge hose to the valve at the bottom of the cylinder. If the refrigerant is R410A, make the cylinder bottom up to ensure liquid charge.

2). Purge the air from the charge hose.

Open the valve at the bottom of the cylinder and press the check valve on the charge set to purge the air (be careful of the liquid refrigerant).

3) Put the charging cylinder onto the electronic scale and record the weight.

4) Operate the air conditioner at the cooling

mode.

5) Open the valves (Low side) on the charge set and charge the system with liquid refrigerant.

6).When the electronic scale displays the proper weight (refer to the gauge and the pressure of the low side), disconnect the charge hose from the 3-way valve's service port immediately and turn off the air conditioner before disconnecting the hose.

7). Mount the valve stem caps and the service port

Use torque wrench to tighten the service port cap to a torque of 18N.m.

Be sure to check for gas leakage.

## 1.6 Re-installation while the indoor unit need to be repaired

### 1. Collecting the refrigerant into the outdoor unit

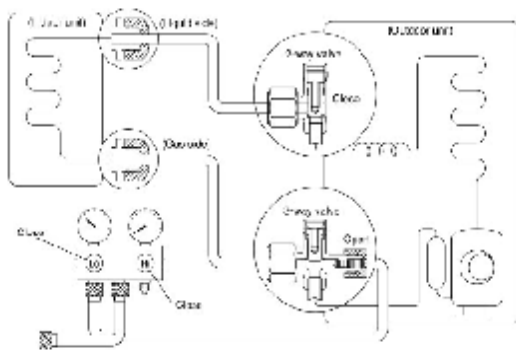

#### Procedure

1). Confirm that both the 2-way and 3-way valves are set to the opened position

Remove the valve stem caps and confirm that the valve stems are in the opened position.

Be sure to use a hexagonal wrench to operate the valve stems.

2). Connect the charge hose with the push pin of handle Lo to the 3-way valves gas service port.

3). Air purging of the charge hose.

Open the handle Lo valve of the manifold valve slightly to purge air from the charge hose for 5 seconds and then close it quickly.

4). Set the 2-way valve to the close position.

5). Operate the air conditioner at the cooling cycle and stop it when the gauge indicates 0.1MPa.

6). Set the 3-way valve to the closed position

immediately

Do this quickly so that the gauge ends up indicating 0.3 to 0.5Mpa.

Disconnect the charge set, and tighten the 2-way and 3-way valve's stem nuts.

Use a torque wrench to tighten the 3-way valves service port cap to a torque of 18N.m.

Be sure to check for gas leakage.

### 2. Air purging by the refrigerant

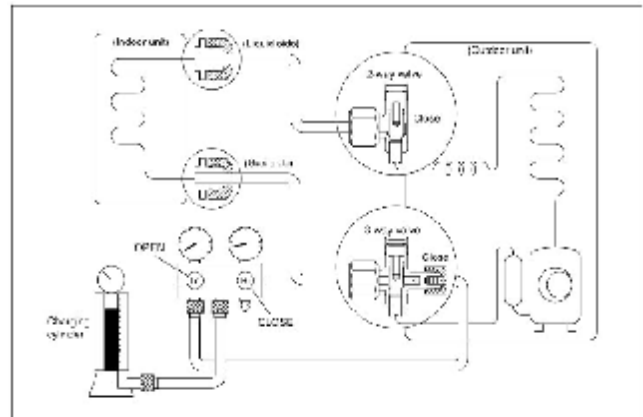

#### Procedure:

1). Confirm that both the 2-way and 3-way valves are set to the closed position.

2). Connect the charge set and a charging cylinder to the service port of the 3-way valve Leave the valve on the charging cylinder closed.

3). Air purging.

Open the valves on the charging cylinder and the charge set. Purge the air by loosening the flare nut on the 2-way valve approximately 45° for 3 seconds then closing it for 1 minute; repeat 3 times.

After purging the air, use a torque wrench to tighten the flare nut on the 2-way valve.

4). Check the gas leakage

Check the flare connections for gas leakage.

5). Discharge the refrigerant.

Close the valve on the charging cylinder and discharge the refrigerant by loosening the flare nut on the 2-way valve approximately 45° until the gauge indicates 0.3 to 0.5 Mpa.

6). Disconnect the charge set and the charging cylinder, and set the 2-way and 3-way valves to the open position

Be sure to use a hexagonal wrench to operate the valve stems.

7). Mount the valve stems nuts and the service port cap

Be sure to use a torque wrench to tighten the service port cap to a torque 18N.m.

Be sure to check the gas leakage.

## 1.7 Re-installation while the outdoor unit need to be repaired

### 1. Evacuation for the whole system

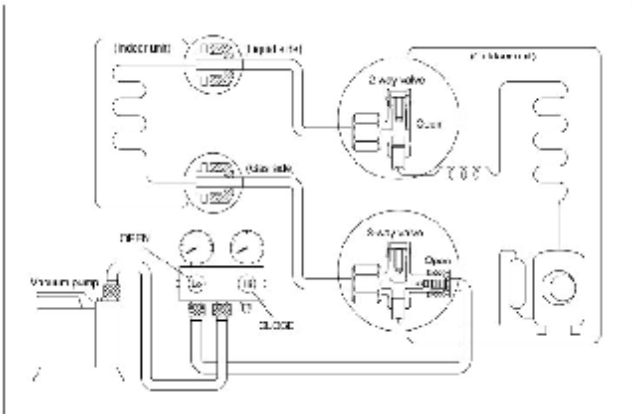

#### Procedure:

- 1). Confirm that both the 2-way and 3-way valves are set to the opened position.
- 2). Connect the vacuum pump to 3-way valve's service port.
- 3). Evacuation for approximately one hour. Confirm that the compound meter indicates -0.1Mpa.
- 4). Close the valve (Low side) on the charge set, turn off the vacuum pump, and confirm that the gauge needle does not move (approximately 5 minutes after turning off the vacuum pump).
- 5). Disconnect the charge hose from the vacuum pump.

### 2. Refrigerant charging

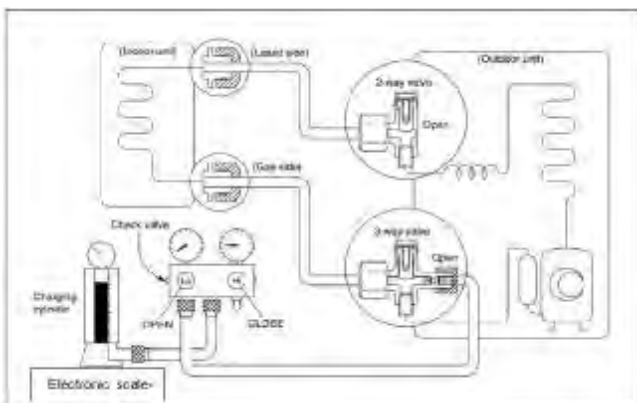

#### Procedure:

- 1). Connect the charge hose to the charging cylinder, open the 2-way valve and the 3-way valve

Connect the charge hose which you disconnected from the vacuum pump to the valve at the bottom of the cylinder. If the refrigerant is R410A, make the cylinder bottom up to ensure liquid charge.

- 2). Purge the air from the charge hose

Open the valve at the bottom of the cylinder and press the check valve on the charge set to purge the air (be careful of the liquid refrigerant).

- 3) Put the charging cylinder onto the electronic scale and record the weight.

- 4). Open the valves (Low side) on the charge set and charge the system with liquid refrigerant

If the system cannot be charge with the specified amount of refrigerant, or can be charged with a little at a time (approximately 150g each time) , operating the air conditioner in the cooling cycle; however, one time is not sufficient, wait approximately 1 minute and then repeat the procedure.

- 5).When the electronic scale displays the proper weight, disconnect the charge hose from the 3-way valve's service port immediately

If the system has been charged with liquid refrigerant while operating the air conditioner, turn off the air conditioner before disconnecting the hose.

- 6). Mounted the valve stem caps and the service port

Use torque wrench to tighten the service port cap to a torque of 18N.m.

Be sure to check for gas leakage.



## 2. Operation Characteristics

Mode	Cooling operation	Heating operation	Drying operation
Temperature			
Room temperature	17°C~32°C (62°F~90°F)	0°C~30°C (32°F~86°F)	10°C~32°C (50°F~90°F)
Outdoor temperature	18°C~43°C (64°F~109°F)	-7°C~24°C (20°F~78°F)	11°C~43°C (52°F~109°F)
	-7°C~43°C (20°F~109°F) (For the models with low temperature cooling system)		18°C~52°C (64°F~126°F) (For special tropical models)
	18°C~52°C (64°F~126°F) (For special tropical models)		

### CAUTION:

1. If the air conditioner is used beyond the above conditions, certain safety protection features may come into operation and cause the unit to operate abnormally.
2. The room relative humidity should be less than 80%. If the air conditioner operates beyond this figure, the surface of the air conditioner may attract condensation. Please set the vertical air flow louver to its maximum angle (vertically to the floor), and set HIGH fan mode.
3. The optimum performance will be achieved during this operating temperature zone.

### 3. Electronic function

#### 3.1 Abbreviation

T1: Indoor room temperature

T2: Coil temperature of evaporator

T3: Coil temperature of condenser

T4: Outdoor ambient temperature

#### 3.2 Display function

7.2.1 Icon explanation on indoor display board.



Digital display:

Displays the temperature settings when the air conditioner is operational.

Displays the room temperature in FAN mode.

Displays the self-diagnostic codes.

Displays 'ON' for three seconds when Timer ON, Fresh, Swing, Turbo or Silence feature is activated.

Displays 'OF' for three seconds when Fresh, Swing, Turbo or Silence feature is cancelled.

Displays 'dF' under defrosting operation.

Displays 'cF' when anti-cold air feature is activated under heating mode.

Displays 'SC' during self clean operation (if applicable).

Displays 'FP' under 8°C heating operation (if applicable).

NOTE:

A guide on using the infrared remote is not included in this literature package.

### 3.3 Main Protection

#### 3.3.1 Time Delay at restart for compressor.

Less than 1 minute delay for the 1<sup>st</sup> time start-up and 3 minutes delay for others.

#### 3.3.2 Sensor protection at open circuit and breaking disconnection.

#### 3.3.3 Zero crossing detection error protection

If AC can not detect zero crossing signal for 4 minutes or the zero crossing signal time interval is not correct, the unit will stop and the LED will display the failure. The correct zero crossing signal time interval should be between 6-13ms.

#### 3.3.4 Fan Speed is out of control

When Indoor Fan Speed is too low(lower than 300RPM) lasting 2 minutes, the unit stops and LED displays failure information and can't returns to normal operation automatically.

#### 3.3.5 Current protection

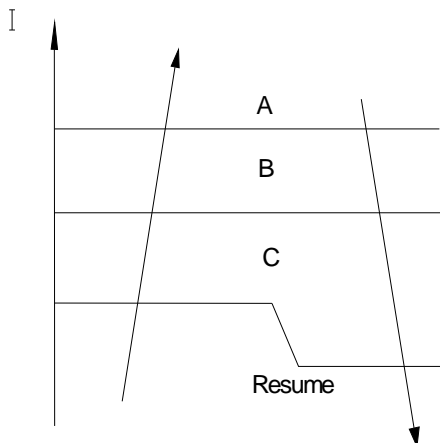

The current exceeds setting value for certain time, the compressor and outdoor fan will shut off.

#### 3.3.6 Indoor fan delayed open function

When the unit starts up, the indoor fan will open 4s later. If the unit runs in heating mode, the indoor fan will be also controlled by anti-cold wind function.

#### 3.3.7 Refrigerant leakage detection

This function is only active in cooling mode. It can better prevent the compressor being damaged by refrigerant leakage or compressor

overload.

Open condition:

When compressor is active, the value of the Coil temperature of evaporator T2 has no change or very little change.

### 3.4 Operation Modes and Functions

#### 3.4.1 Fan mode

- (1) Outdoor fan and compressor stop.
- (2) Temperature setting function is disabled, and no setting temperature is displayed.
- (3) Indoor fan can be set to high/med/low/auto.
- (4) The louver operates the same as in cooling mode.
- (5) Auto fan:

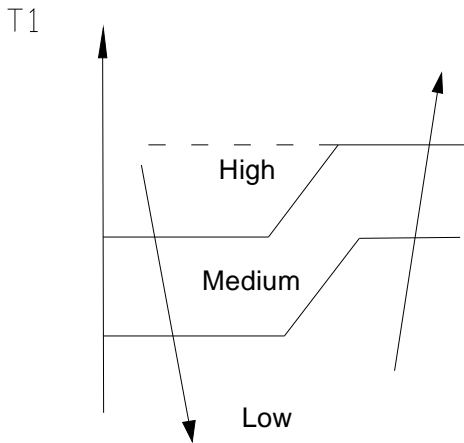

#### 3.4.2 Cooling Mode

##### 3.4.2.1 Compressor running rules

When indoor room temp.  $T_1$  is lower than setting value, the compressor and outdoor fan will shut off.

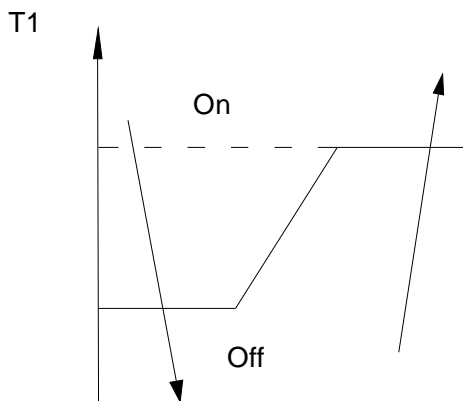

##### 3.4.2.2 Outdoor fan running rules

The On-off outdoor units have single fan speed. The outdoor fan will run following the compressor except when AC is in evaporator high temp. protection in heating mode, condenser high temp. protection in cooling mode, defrosting mode and the current

protection.

##### 3.4.2.3 Indoor fan running rules

In cooling mode, indoor fan runs all the time and the speed can be selected as high, medium, low and auto.

The auto fan:

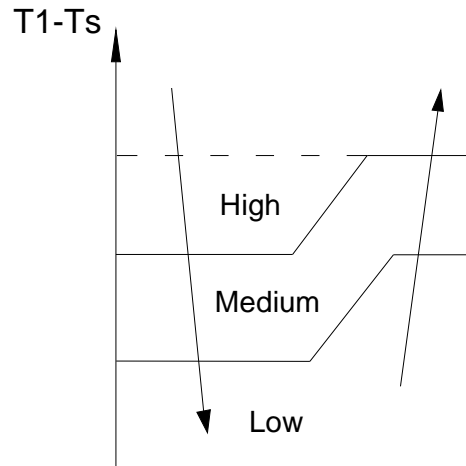

##### 3.4.2.4 Low evaporator coil temperature $T_2$ protection

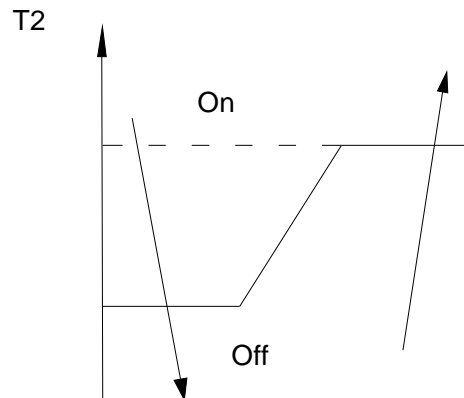

When the evaporator coil temp.  $T_2$  keeps lower than setting value, the compressor and outdoor fan will shut off.

##### 3.4.2.5 High condenser temperature $T_3$ protection

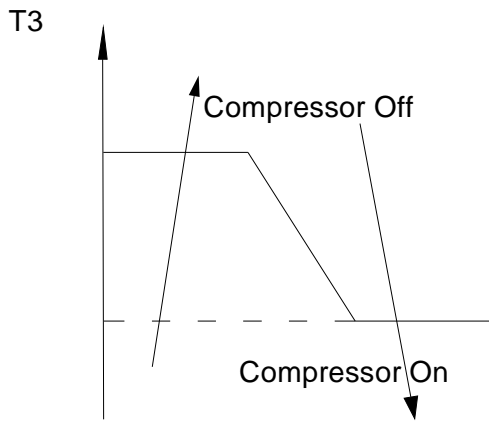

When high condenser temp. T3 is more than setting value, the compressor will stop. During the protection, the outdoor fan keeps working.

### 3.4.3 Heating Mode (for heat pump models)

#### 3.4.3.1 Compressor running rules:

When indoor room temp. T1 is higher than setting value the compressor and outdoor fan will shut off.

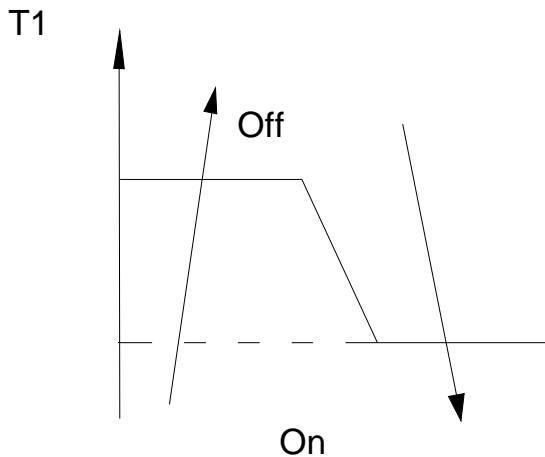

#### 3.4.3.2 Outdoor fan running rules:

The outdoor units have single fan speed. The outdoor fan will run following the compressor except when AC is in evaporator high temp. protection in heating mode, condenser high temp. protection in cooling mode, defrosting mode and the current protection.

#### 3.4.3.3 Indoor fan running rules:

When the compressor is on, the indoor fan can be set to high/med/low/auto. And the anti-cold wind function has the priority.

#### Auto fan action:

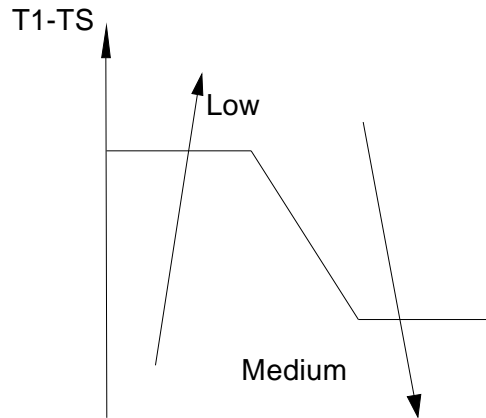

The indoor fan speed will adjust according to the value of T1-T<sub>s</sub>.

#### 3.4.3.4 Defrosting mode:

##### For TMSAB09HT1A, TMSAB12HT1A, TMSAB18HT1A, models:

AC will enter the defrosting mode according to the value of temp difference between T2 and T1, and also the compressor running time. During the defrosting mode, the compressor keep running, indoor and outdoor motor will stop, defrost lamp of the indoor unit will be lighted

“DF” Will be displayed.

Condition of ending defrosting:

If any one of the following items is satisfied, the defrosting will terminate and the machine will turn to normal heating mode.

- (1) The defrosting time is reached to the setting value.
- (2) The defrosting has been running for 3 minutes and  $T_2 \geq TCDE1^\circ C$ .
- (3) The defrosting has been running for 2 minutes, check the value of T2. If  $T_2 - T_{2min} \geq TCDE2^\circ C$  during 4 minutes, the defrosting will terminate.

##### For TMSAB24HT1A,

**TMSAB30HT1A, TMSAB36HT1A, models:**

AC will enter the defrosting mode according to the value of temp. of T3 and the value range of temp. change of T3 and also the compressor running time.

During the defrosting mode, the compressor keep running, indoor and outdoor motor will stop, defrost lamp of the indoor unit will be

lighted. “**DF**.” Will be displayed.

Condition of ending defrosting:

If any one of the following items is satisfied, the defrosting will terminate and the machine will turn to normal heating mode.

- (1) T3 rises to be higher than TC2.
- (2) The machine has run for 10 minutes in defrosting.

**3.4.3.5 High evaporator coil temp.T2 protection:**

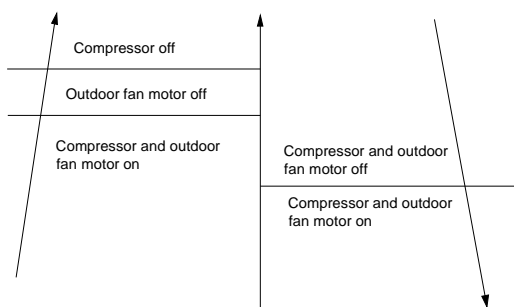

**3.4.4 Auto-mode**

This mode can be chosen with remote controller.

In auto mode, the machine will choose operation mode according to  $\Delta T$  ( $\Delta T = T1 - Ts$ ).

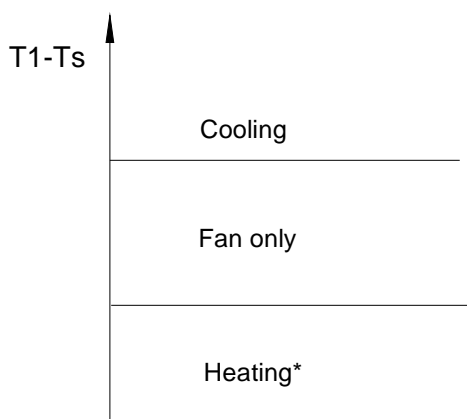

Heating\*: For cooling only models, they will run at fan speed

AC will run in auto mode in the below cases:

- (1) Pressing the forced auto button.
- (2) If AC is off, it will run in auto mode when the timer on function is active.
- (3) After setting the mode, AC will run in auto mode if the compressor keeps not running for certain time.

**3.4.5 Drying mode**

7.4.5.1 The compressor is cycled running with 10 minutes on and then 5 minutes off. The indoor fan will keep running at low speed.

7.4.5.2 In drying mode, if room temperature is lower than 10°C, the compressor will stop and not resume until room temperature exceeds 13°C.

7.4.5.3 The evaporator anti-freezing protection is the same as that in cooling mode.

**3.4.6 Forced operation function**

Forced cooling mode:

The compressor and outdoor fan keep running and the indoor fan runs at low speed. After running for 30 minutes, AC will turn to auto mode with 24°C setting temperature.

Forced auto mode:

The action of forced auto mode is the same as normal auto mode with 24°C setting temperature.

When AC receives signals, such as switch on, switch off, timer on, timer off, mode setting, fan speed setting, sleeping mode setting, follow me setting, it will quit the forced operation.

**3.4.7 Auxiliary heater function (Only for the units with this function)**

AC will enter the Auxiliary heater function if all of the following items are satisfied.

- 1) Heating mode.
- 2) PTC Auxiliary heater function is on.
- 3) The compressor is on and last over 6 seconds.
- 4) The indoor fan is on.
- 5)  $T2 < 47^\circ\text{C}$ .

6) Non-defrosting mode.

7)  $T1 < 31^{\circ}\text{C}$ .

AC will exit the Auxiliary heater function if one of the following items are satisfied.

1) Non-heating mode.

2) PTC Auxiliary heater function is off.

3) The compressor is off.

4) The indoor fan is off.

5)  $T2 > 51^{\circ}\text{C}$  last 3 minutes.

6) In defrosting mode.

7)  $T1 > 33^{\circ}\text{C}$  last 3 minutes.

### 3.4.8 Auto-Restart function

The indoor unit is equipped with auto-restart function, which is carried out through an auto-restart module. In case of a sudden power failure, the module memorizes the setting conditions before the power failure. The unit will resume the previous operation setting (not including swing function) automatically after 3 minutes when power returns.

If the memorization condition is forced cooling mode, the unit will run in cooling mode for 30 minutes and turn to auto mode as  $24^{\circ}\text{C}$  setting temp.

If AC is off before power off and AC is required to start up now, the compressor will have 1 minute delay when power on. Other conditions, the compressor will have 3 minutes delay when restarts.

### 3.4.9 Refrigerant Leakage Detection

With this new technology, the display area will show "EC" when the outdoor unit detects refrigerant leakage.

When compressor is active, the value of the Coil temperature of evaporator T2 has no change or very little change.

### 3.4.10 $8^{\circ}\text{C}$ Heating(optional)

When the compressor is running, the indoor fan motor will run without anti-cold air function.

When the compressor is off, the indoor fan motor is off.

### 3.4.11 Self clean(optional)

For heat pump models which are provided with this function, after running in cooling or drying mode, if the user press "Self Clean" button on remote controller, firstly, indoor unit runs in fan only mode for a while, then low heat operation and finally runs in fan only again. This function can keep the inside of indoor unit dry and prevent breeding of mold.

### 3.4.12 Follow me (optional)

1) If the indoor PCB receives the signal which results from pressing the FOLLOW ME button on remote controller, the buzzer will emit a sound and this indicates the follow me function is initiated. But when the indoor PCB receives signal which sent from remote controller every 3 minutes, the buzzer will not respond. When the unit is running with follow me function, the PCB will control the unit according to the temperature from follow me signal, and the temperature collection function of room temperature sensor will be shielded, but the error detective function of room temperature sensor will be still valid.

2) When the follow me function is available, the PCB will control the unit according to the room temperature from the remote controller and the setting temperature.

3) The PCB will take action to the mode change information from remote controller signal, but it will not be affected by the setting temperature.

4) When the unit is running with follow me function, if the PCB doesn't receive any signal from remote controller for 7 minutes or pressing FOLLOW ME button again, the follow me function will be turned off automatically, and the temperature will control the unit according to the room temperature detected from its own room temperature sensor and setting temperature.



Air Conditioning Systems

Cooling & Heating

**TRUST AIR-CONDITIONING EQUIPMENT CO.**

Shiraz office: 8 th floor, Alvand Bldg., Dostan St.,  
Moaliabad Ave., SHIRAZ, IRAN., Post code: 71877-14446

Tel.: +98-71-36341070

Fax.: +98-71-36341094

Tehran office: No. 19- koohe nour St.- Motahhari St.-

TEHRAN, IRAN., Post code: 15876-73111

Tel.: +98-21-89389

Fax.: +98-21-88541903

Ahwaz office: No. 309- Kaveh St.- AHWAZ, IRAN., Post code: 61939-  
47911

Tel.: +98-61-32230647-8 E-mail: [info@trustacs.com](mailto:info@trustacs.com)

Fax.: +98-61-32230647 Web site: <http://www.trustacs.com>

برند برتر در اولین جشنواره بین المللی  
برترین نام و نشان های تجاری ایران

