

MINI UNITARY CHILLER



TRUST AIR CONDITIONING EQUIPMENT CO.
Prepared By: Engineering & R & D Department.

1. General Information	2
2. Description of Standard Unit.....	3
3. Installation of Outdoor Unit.....	4
4. Hydraulic Connection	6
5. Electrical Connection	9
6. Checking and Starting Up the Unit	12
7. Running and Maintenance.....	14
8. Standard controller.....	17
9. Optional controller.....	30

1. General Information

General warning

1. These units have been designed to chill and heat water and must be used in applications compatible with their performance characteristics; these appliances are designed for residential or similar applications.
2. Incorrect installation, regulation and maintenance or improper use absolves the manufacturer from all liability, whether contractual or otherwise, for damage to people, animals or things. Only those applications specifically indicated in this list are permitted.
3. Read this manual carefully. All work must be carried out by qualified personnel in conformity with legislation in force in the country concerned.
4. The guarantee is invalidated if the above instructions are not respected and if the unit is started up for the first time without the presence of personnel authorized by the Company (where specified in the supply contract) who should draw up a “start-up” report.
5. The documentation supplied with the unit must be consigned to the owner who should keep it carefully for future consultation in the event of maintenance or service.
6. All repair or maintenance work must be carried out by the Company’s Technical Service or qualified personnel following the instructions in this manual. The air-conditioner must under no circumstances be modified or tampered with as this may create situations of risk. Failure to observe this condition absolves the manufacturer of all liability for resulting damage.

Fundamental safety rules

When operating equipment involving the use of electricity and water, a number of fundamental safety rules must be observed, namely:



Prohibition

1. This appliance is not intended for use by persons (including children) with reduced physical, sensory or mental capabilities, or lack of experience and knowledge, unless they have been given supervision or instruction concerning use of the appliance by a person responsible for their safety.
2. Do not touch the unit with bare feet or with wet or damp parts of the body
3. Do not carry out cleaning operations without first disconnecting the system from the electricity supply.
4. Do not modify safety or regulation devices without authorization and instructions from the manufacturer.
5. Do not pull, detach or twist the electrical cables coming from the unit, even when disconnected from the mains electricity supply.
6. Do not open doors or panels providing access to the internal parts of the unit without first ensuring that the mains switch is in the off position.
7. Do not introduce pointed objects through the air intake and outlet grills.
8. Do not dispose of, abandon or leave within reach of children packaging materials (cardboard, staples, plastic bags, etc.) as they may represent a hazard.



Important

1. The chiller appliances are supplied without the main switch. The power supply to the unit must be disconnected using a suitable main switch that must be supplied and installed by the installer.
2. Respect safety distances between the unit and other equipment or structures. Guarantee adequate space for access to the unit for maintenance and/or service operations;
Power supply: the cross section of the electrical cables must be adequate for the power of the unit and the power supply voltage must correspond with the value indicated on the respective units. All units must be earthed in conformity with legislation in force in the country concerned.
3. Hydraulic connections should be carried out as indicated in the instructions to guarantee correct operation of the unit. Empty the water circuit or add glycol if the unit is not used during the winter. Handle the unit with the utmost care to avoid damage.

2. Description of Standard Unit

These air cooled reverse-cycle chillers with axial-flow fans operate with refrigerant fluid and are suitable for outdoor installation.

They are factory tested and on site installation is limited to water and electrical connections.

Structure:

Panels and base are made from galvanized steel plate painted with epoxy powder to ensure total resistance to atmospheric agents. Condensate collection pan as standard.

Compressors:

Scroll compressor with crankcase heater and thermal cut-out.

Evaporator:

AISI 316 stainless steel plate type evaporator complete with electric heater and differential pressure switch. Casing lined with anti-condensate closed cell neoprene cladding.

Pump:

The units feature a pump with the moving parts in contact with the water made from corrosion resistant materials, extra wear ring on the impeller, built-in capacitor for high starting torque and automatic venting of impeller chamber.

Pump assembly:

Pump assembly with expansion tank, safety valve, auto water replenishing assembly, pressure gauge and pump.

Condensing coil:

Made from copper tubes and high surface area aluminum fins. Condensing coil protection grills as standard.

Fans:

Axial-flow fans. Six-pole electric motor with built-in thermal cut-out. Housed in aerodynamic tubes with accident prevention grill. Device for operation with low outside air temperatures: continuous fan rotation speed control via condensing temperatures transducer.

Power and control electrical panel

Power and control electrical panel constructed in accordance with IEC 204-1/EN60335-2-40, complete with compressor contactor. Control via "HSW7" control panel.

Emergency stop push buttons

In case system crisis is occur (e. g: Compressor out of control), press the emergency stop pushbuttons at once, and turn it clockwise, until crisis is removed.

Optional accessories:

- Removable metal mesh filter.
- Remote keyboard kit.
- Additional pump.

The above accessories are optional. Consult the relative documentation for assembly instructions and technical data.

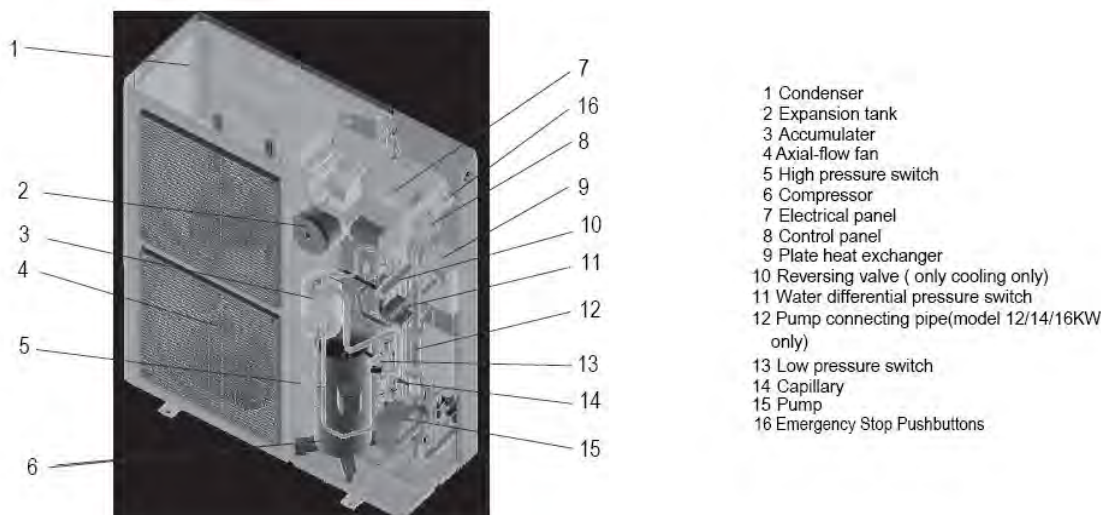

3. Installation of Outdoor Unit

3.1 Choice of installation site

Before installing the unit, agree with the customer the site where it will be installed, taking the following points into consideration:

- check that the fixing points are adequate to support the weight of the unit;
- pay scrupulous respect to safety distances between the unit and other equipment or structures to ensure that air entering the unit and discharged by the fans is free to circulate.

3.2 Positioning

Before handling the unit, check the capacity of the lifting equipment used, respecting the instructions on the packaging.

To move the unit in the horizontal, make appropriate use of a lift truck or similar, bearing in mind the weight distribution of the unit. To lift the unit, insert tubes long enough to allow positioning of the lifting slings and safety pins in the feet on the unit.

To avoid the slings damaging the unit, place protection between the slings and the unit. Position the unit in the site indicated by the customer. Place either a layer of rubber (min. thickness 10 mm) or vibration damper feet (optional) between the base and support surface. Fix the unit, making sure it is level and that there is easy access to hydraulic and electrical components. If the site of installation is exposed to strong winds, fix the unit adequately to the support surface using tie rods if necessary. If a heat pump unit is being installed, make sure the condensate is drained using the drain hose supplied as standard. Prevent leaves, branches or snow from accumulating around the unit. These could reduce the efficiency of the unit.

3.3 Service space

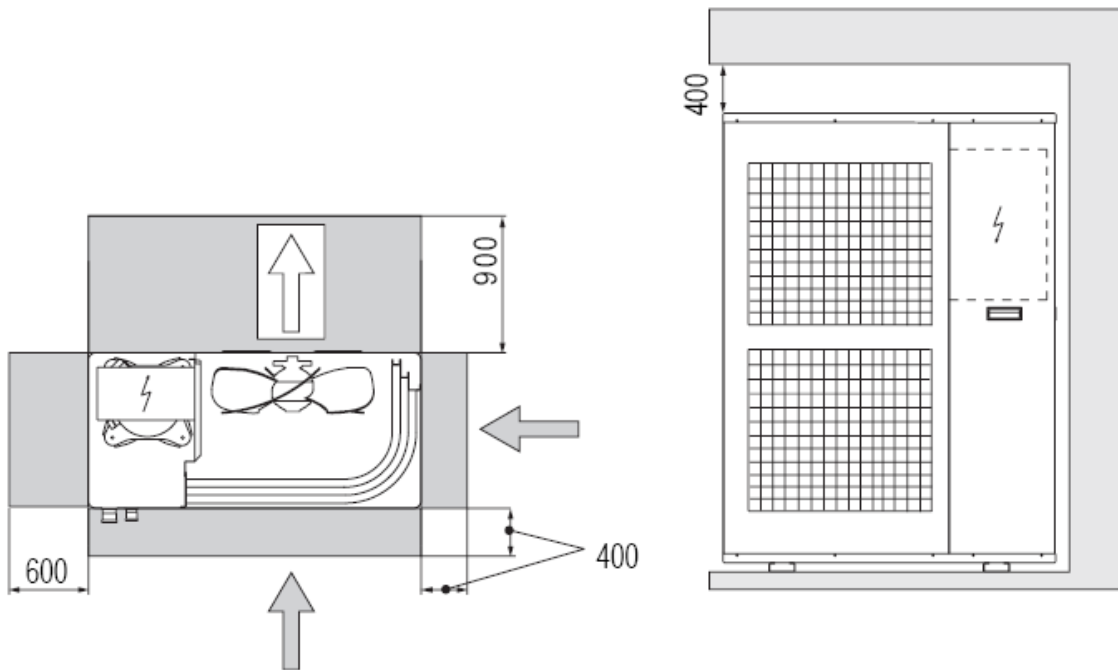
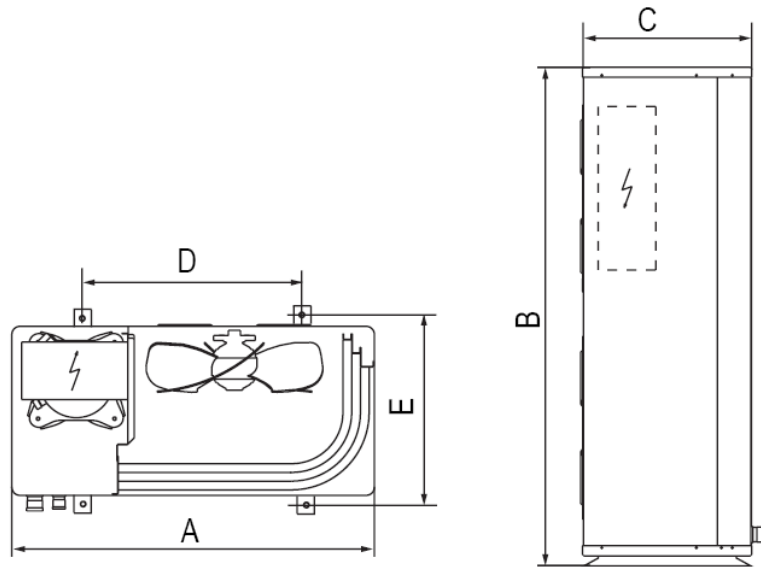

Dimension	A	B	C	D	E
TMCHMUF-10H410	940	1245	360	600	376
TMCHMUF-10H410/380	940	1245	360	600	376
TMCHMUF-14H410	1070	1249	420	698	430
TMCHMUF-16H410	1070	1249	420	698	430

4. Hydraulic Connection

The choice and installation of components is the responsibility of the installer who should follow good working practice and current legislation. Before connecting the pipes, make sure they do not contain stones, sand, rust, dross or other foreign bodies which might damage the unit. Construction of a bypass is recommended to enable the pipes to be washed through without having to disconnect the unit (see drain valves). The connection piping should be supported in such a way as to avoid it weighing on the unit. It is recommended that the following devices are installed in the water circuit of the evaporator:

1. Two pressure gauges with a suitable (inlet and outlet)
2. Two vibration damper joints (inlet and outlet)
3. Two gate valves (normal inlet and calibrating in outlet)
4. A flow switch (inlet) or a differential pressure switch (inlet-outlet).
5. Two thermometers (inlet and outlet).
6. An inlet filter as close as possible to the evaporator and positioned to allow easy access for routine maintenance.
7. An energy-saving water tank.
8. Additional pump.
9. The connecting line of flow switch, which mounted outside the unit, should be connected in series with the pressure-difference

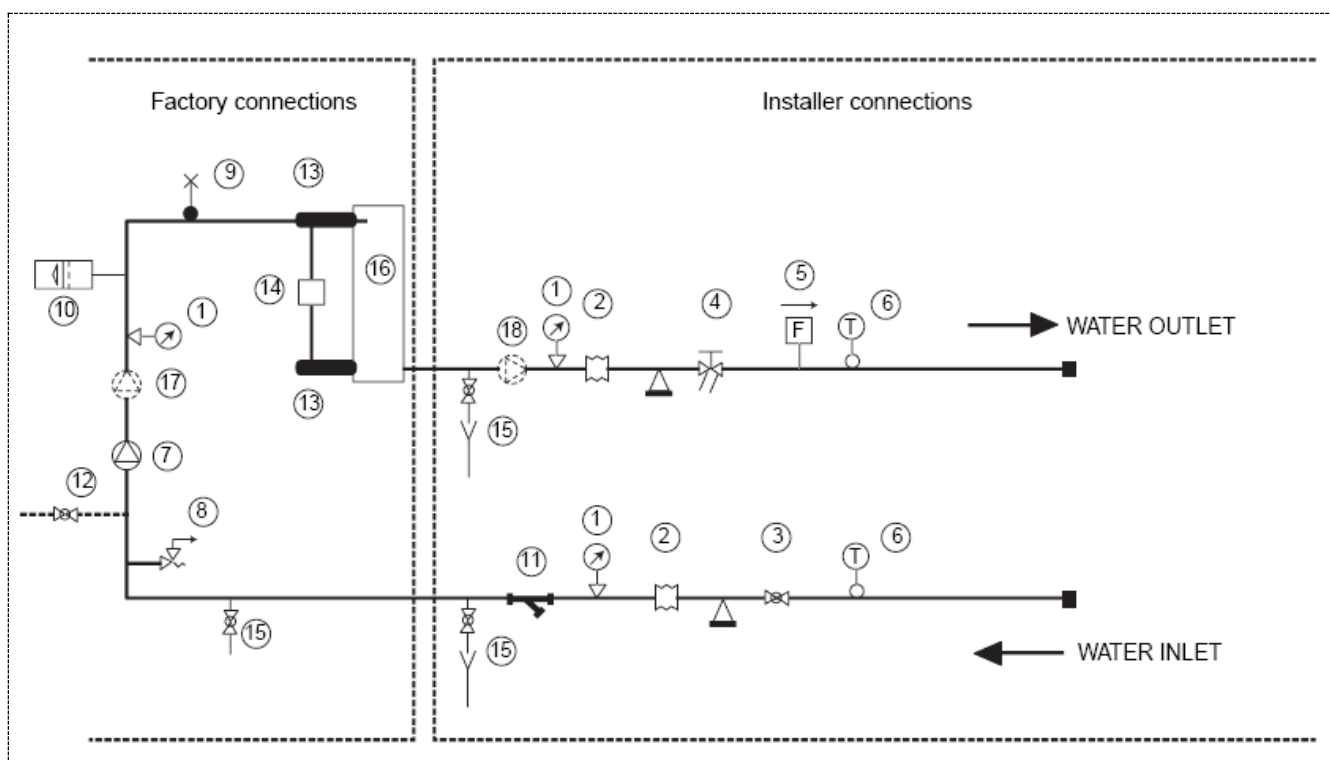

No	Name	No	Name	No	Name
1	Pressure gauge	7	Pump	13	Temperature sensor
2	Vibration damper joint	8	Safety valve	14	Differential pressure switch
3	Gate valve	9	Air vent	15	Drain/chemical washing valve
4	Calibrating valve	10	Expansion tank	16	Plate heat exchanger
5	Flow switch	11	Mesh filter	17	Additional pump
6	Thermometer	12	Auto-water replenishing	18	Additional pump

If the installation requires a useful head higher than that obtained by installing a pump assembly and storage tank, it is recommended that an additional pump is installed on the unit. Provided the additional pump installed inside of unit (**only model 12/14/16kW can be installed inside of unit**), the pump must connected

close to plate heat exchanger. Provided the pump installed outside of unit, the pump shall be connected at water pipe's outlet. The pump can be easily installed on the unit by removing the pump connection pipe.

Important

- 1) The chillers must be provided with a filling/top-up system connected to the return line and a drain cock in the lowest part of the installation. Installations containing anti-freeze or covered by specific legislation must be fitted with hydraulic disconnections.
- 2) The manufacturer is not liable for obstruction, breakage or noise resulting from the failure to install filters or vibration dampers. Particular types of water used for filling or topping up must be treated with appropriate treatment systems. For reference values, see the table.

PH	6-8
Electrical conductivity	less than 200 mV/cm (25° C)
Chlorine ions	less than 50 ppm
Sulphuric acid ions	less than 50 ppm
Total iron	less than 50 ppm
Alkalinity M	less than 50 ppm
Total hardness	less than 50 ppm
Sulphur ions	none
Ammonia ions	none
Silicon ions	less than 30 ppm

Filling the installation

- Before filling, check that the installation drain cock is closed.
- Open all installation and terminal air vents.
- Open the gate valves.
- Begin filling, slowly opening the water filling cock outside the unit
- When water begins to leak out of the terminal air vent valves, close them and continue filling until the pressure gauge indicates a pressure of 1.5 bars.

Emptying the installation

- Before emptying, place the mains switch in the "off" position
- Make sure the installation fill/top-up water cock is closed
- Open the drain cock outside the unit and all the installation and terminal air vent valves.

Size and position of connections

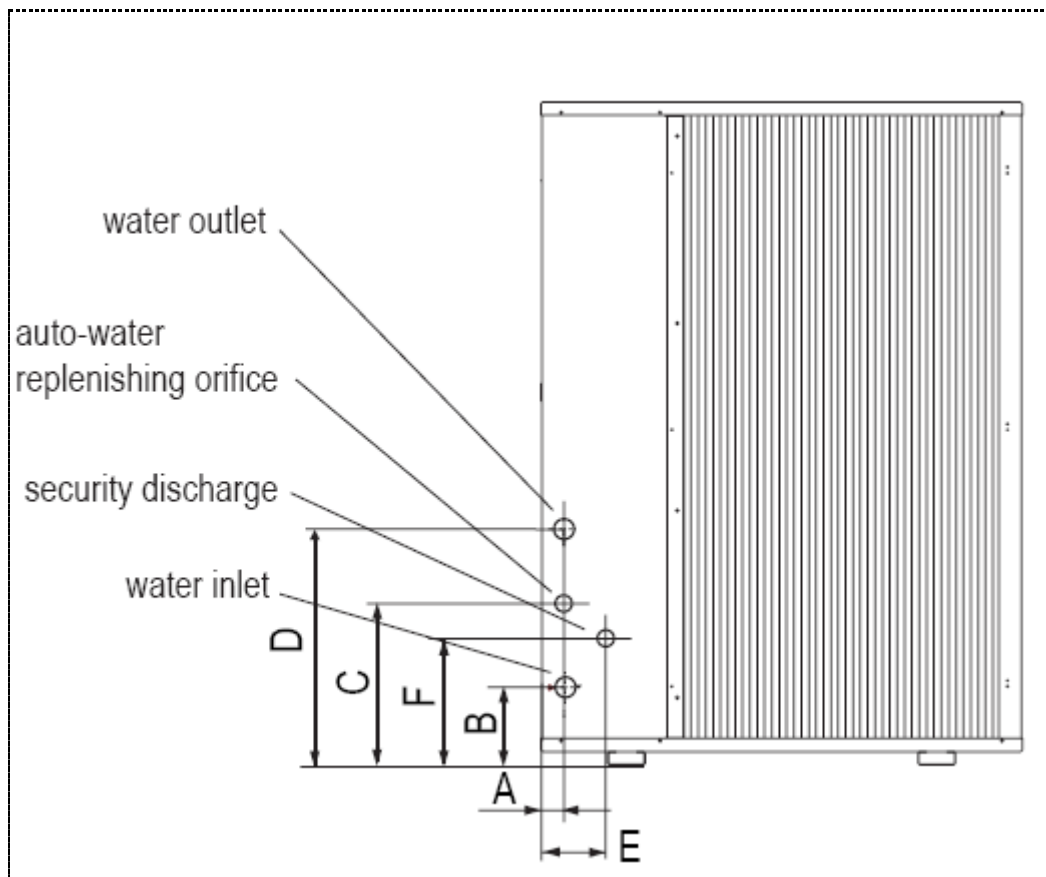

Model	A (mm)	B (mm)	C (mm)	D (mm)	E (mm)	F (mm)	Water inlet/outlet (Ø)	Auto-water replenishing (Ø)	Security discharge (Ø)
TMCHMUF-10H410	76	107	217	305	145	107	R5/4	G1/2	G1/2
TMCHMUF-10H410/380	76	107	217	305	145	107	R5/4	G1/2	G1/2
TMCHMUF-14H410	78	84	174	297	148	148	R5/4	G1/2	G1/2
TMCHMUF-16H410	78	84	174	297	148	148	R5/4	G1/2	G1/2

Important

- The installation must be filled to a pressure of between 1 and 2 bars.
- It is recommended that this operation be repeated after the unit has been operating for a number of hours. The pressure of the installation should be checked regularly and if it drops below 1 bar, the water content should be topped-up.
- Check the hydraulic tightness of joints.
- If the fluid in the circuit contains anti-freeze, it should not be allowed to drain freely as it is pollutant.
- It should be collected for possible reuse.
- When draining after heat pump operation, take care as the water may be hot (up to 50°C).

5. Electrical Connection

The MGC chillers leave the factory already wired, and require the installation of an omnipolar thermal overload switch, a lockable mains disconnecting switch for the connection to the mains power supply, and the connection of the flow switch to the corresponding terminals. All the above operations must be carried out by qualified personnel in compliance with the legislation in force.

For all electrical work, refer to the electrical wiring diagrams in this manual. You are also recommended to check that the characteristics of the mains electricity supply are adequate for the absorptions indicated in the electrical characteristics table below, also bearing in mind the possible use of other equipment at the same time.

Important

- Power to the unit must be turned on only after installation work (hydraulic and electrical) has been completed.
- All electrical connections must be carried out by qualified personnel in accordance with legislation in force in the country concerned.
- Respect instructions for connecting phase, neutral and earth conductors.
- The power line should be fitted upstream with a suitable device to protect against short-circuits and leakage to earth, isolating the installation from other equipment.
- Voltage must be within a tolerance of $\pm 10\%$ of the rated power supply voltage for the unit (for three phase units, the unbalance between the phases must not exceed 3%). If these parameters are not respected, contact the electricity supply company.
- For electrical connections, use double insulation cable in conformity with current legislation in the country concerned
- An omnipolar thermal overload switch and a lockable mains disconnecting switch, in compliance with the CEI-EN standards (contact opening of at least 3mm), with adequate switching and residual current protection capacity based on the electrical data table shown below, must be installed as near as possible to the appliance
- The devices on the unit must be lockable. An efficient earth connection is obligatory. Failure to earth the appliance absolves the manufacturer of all liability for damage.
- In the case of three phase units, ensure the phases are connected correctly.
- Do not use water pipes to earth the unit.

Electrical Panel

The electrical panel is located inside the unit at the top of the technical compartment where the various components of the refrigerant circuit are also to be found.

To access the electrical panel, remove the front panel of the unit by undoing the screws.

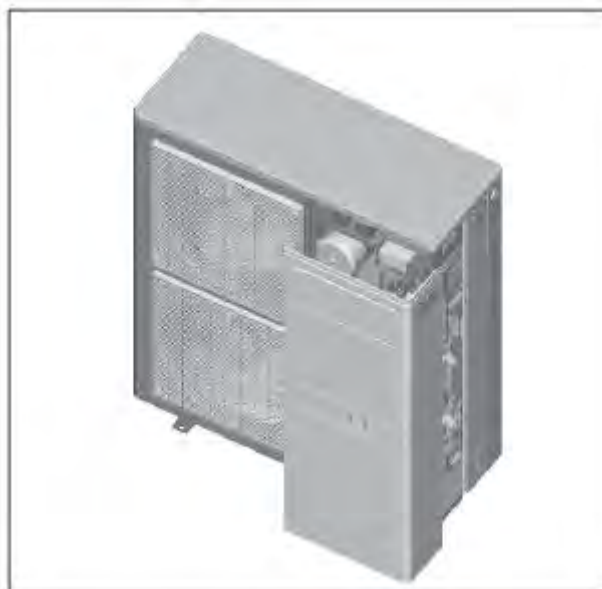

Electrical Panel Layout

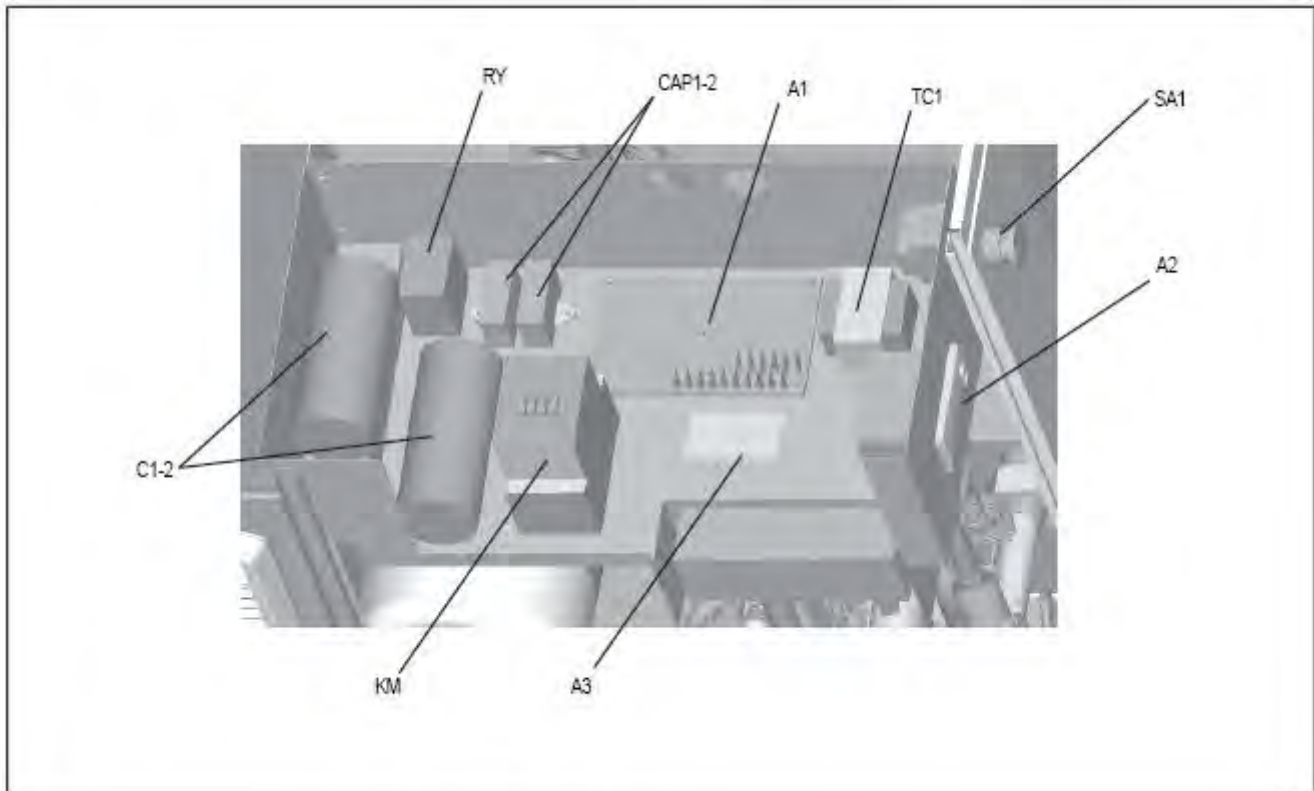

SA1 Emergency switch
 A2 Electronic controller
 RY Compressor start relay
 A1 Power control board

C1-2 Compressor capacitor
 CAP1-2 Fan capacitor
 KM Compressor contactor
 T1 Safety transformer

A3 FILTER

Electrical Power Connection

For the functional connection of the unit, bring the power supply cable to the electrical panel inside the unit and connect it to terminals L-N and respecting the (L) phase, (N) neutral and earth in the case of single phase units (220-240V~50Hz), or L1-L2-L3 phases, N neutral and PE earth in three phase units (380~415V-3N-50Hz).

Auxiliary Connection

All terminals referred to in the explanations below are to be found on the terminal board inside the electrical panel and described as “installer terminals”.

Remote start up and shut down

To fit a remote on/off device, the jumper must be replaced with a switch connected to terminals 4 and 5 on the installer terminal board. For timed operation, connect a daily or weekly timer between terminals 4 and 5.

Remote keyboard kit



The remote keyboard kit can be used to display all unit functions and access the parameters of the electronic board from a point located at some distance from the unit itself.

It consists of a remote control module.

To install the kit, proceed as follows:

- disconnect the power supply and then access the inside of the electrical panel;
- connect the remote control module with 3 wires to terminals 15, 16 and 17 on the installer terminal board:
 connect terminal 15 to terminal **Black/gnd** on the module;
 connect terminal 16 to terminal **Blue/signal** on the module;
 connect terminal 17 to terminal **Red/+12v** on the module;



Important

To avoid interference due to magnetic fields, the use of shielded cable is recommended. The cable should not be more than 100m long.

The Specification of Power:

Type	TMCHMUF-10H410
Power	220~240-1-50
Circuit breaker/fuse (A)	40/35
Power wiring (mm ²)	3×4.0
Ground wiring (mm ²)	4.0
Outdoor /Indoor connecting wiring (mm ²)	1.0

Type	TMCHMUF-10H 410/380	TMCHMUF-14H 410	TMCHMUF-16H 410
Power	380~415-3-50	380~415-3-50	380~415-3-50
Circuit breaker/fuse (A)	25/15	25/15	30/20
Power wiring (mm ²)	5×2.5	5×2.5	5×4.0
Ground wiring (mm ²)	2.5	2.5	4.0
Outdoor /Indoor connecting wiring (mm ²)	1.0	1.0	1.0



Important

The power cord type designation is H07RN-F.

Connecting cable between indoor unit and outdoor unit shall be approved poly-chloroprene sheathed flexible cord, type designation H07RN-F or heavier cord.

The means for disconnection from a power supply shall be incorporated in the fixed wiring and have an air gap contact separation of at least 3mm in each active(phase) conductors.

6. Checking and Starting Up the Unit

6.1 Preparing for first start up

Restarting after shutting down for long periods

The chiller must be started up for the first time by the Technical Service. Before starting up the chillers, make sure that:

- All safety conditions have been respected
- The chiller is adequately fixed to the surface it rests on
- Functional distances have been respected;
- Hydraulic connections have been carried out as indicated in the instruction manual
- The water circuit is filled and vented. When draining after heat pump operation, take care as the water may be hot;
- The water circuit valves are open
- Electrical connections have been carried out correctly
- Voltage is within a tolerance of 10% of the rated voltage for the unit
- The unit is correctly earthed
- All electrical and hydraulic connections are tight and have been completed correctly.

Important

The unit must be started up for the first time with standard settings. Set point values may be modified only after testing has been completed. Before starting up, power the unit for at least two hours by switching QF1 and QS1 to ON and setting the control panel "HSW7" to OFF to allow the oil in the compressor sump to heat up.

6.2 Starting up for the first time (after two hours)

Before activating the chiller:

- Make sure the main remote switch QF1 is in the OFF position;

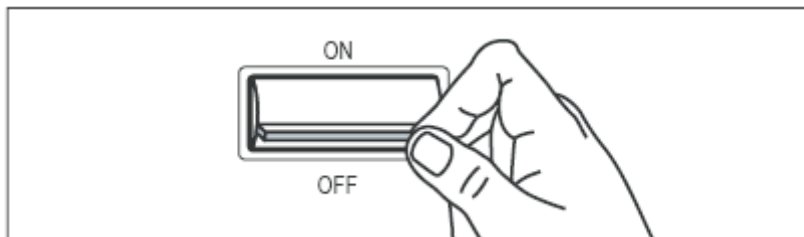

- Make sure the remote secondary switch SA2 is in the OFF or STANDBY position
- Make sure the remote keyboard A6 (if present) is set to OFF

To complete the electrical connections:

- Remove the inspection panel by unscrewing the five screws



- Use grommet A for the electrical power cable and grommet B for the other external wires.

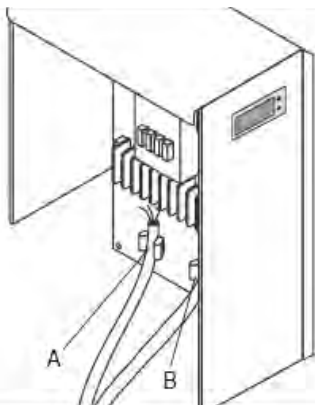

- Replace the inspection panel.
- Position the main switch QF1 (outside the unit) in the "ON" position.
- The "POWER" LED on the control panel "ST542" comes on to signal that voltage is present.

6.3 Activating and deactivating the unit

- Set the remote keyboard "A6" (if present) to ON.

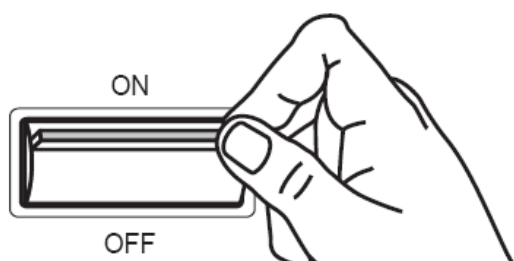

- To ACTIVATE and DEACTIVATE the COOLING and HEATING functions, use the "ST542" control panel or the remote keyboard "A6" if present.

During this phase, if the following indications appear on the display, follow the instructions:

⚠ Important

- E20 check water flow rate and differential pressure switch.

To access the control panel, open the door:

- remove the screw 1 and screw 2;
- lift the door 3.

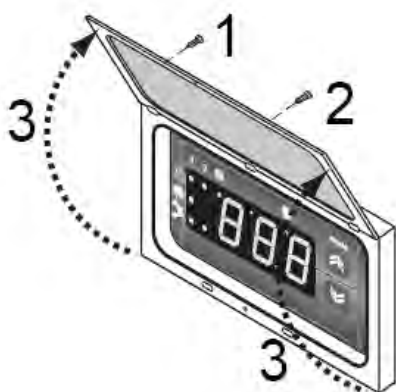

7. Running and Maintenance

7.1 Operating characteristics

Set point in cooling

(factory set) = 10°C, Hysteresis = 3°C.

The compressor starts with water temperatures above 13°C.

The compressor shuts down with water temperatures of less than 10°C.

Set point in heating

(factory set) = 45°C, Hysteresis = 3°C.

The compressor starts with water temperatures below 42°C.

The compressor shuts down with water temperatures above 45°C.

In the event of a temporary power failure, when power returns, the mode set previously will be retained in the memory.

Compressor start up delay

Two functions prevent the compressor from starting up too frequently

- Minimum time since last shut-down 180 seconds.
- Minimum time since last start-up 360 seconds.

Pump

The electronic board includes a pump control output. The pump starts when the assembly is powered up and at least 120 seconds before the compressor starts up and stops 120 seconds after the assembly shuts down. After the first 120 seconds of pump operation when the water flow is at full speed, the water flow alarm functions are activated (differential pressure switch and flow switch). With a pump connected to terminals PL and PN on the installer terminal board.

Fan speed control

For correct operation of the unit with different outside temperatures, the microprocessor controls the fan speed based on the pressure reading from the pressure probe, thus enabling heat exchange to be increased and/or decreased, maintaining the condensing or evaporation temperature practically constant.

The fan functions independently of the compressor.

Frost prevention alarm

To prevent the water freezing and damaging the plate heat exchanger, the microprocessor shuts down the compressor if the temperature measured by the heat exchanger outlet temperature sensor is less than 3°C. The frost prevention temperature set point can be modified by an authorized service centre only and only after verifying that the water circuit contains antifreeze. Tripping of this alarm shuts down the compressor but not the pump, which remains active. To reset normal functions, the outlet water temperature must rise to more than +15°C. Reset is manual.

Water flow alarm

The microprocessor provides for management of a water flow alarm controlled by a differential pressure switch fitted as standard on the appliance to be installed on the water delivery piping.

This safety device may trip after the first 120 seconds of pump operation when the water flow is up to speed. Tripping of this alarm shuts down the compressor but not the pump, which remains active. To reset normal functions, the alarm contact must be deactivated for at least five seconds.

When electrical current exceeds to setting value and condenser temperature over than 65°C, system will shut down, but not returns to normal operation until the condenser temperature decreased less than 52°C. If phase sequence were detected error, please re-input power, and then the system will turn normal.

7.2 Routine maintenance

Never perform any cleaning operations before having disconnected the unit from the mains power supply.

Regular maintenance is fundamental to maintain the efficiency of the unit both in terms of operation and energy consumption. The Technical Assistance Service maintenance plan must be observed, with an annual service which includes the following operations and checks:

- Filling of the water circuit
- Presence of air bubbles in the water circuit
- Efficiency of safety devices
- Power supply voltage
- Power input
- Tightness of electrical and hydraulic connections
- Condition of the compressor contactor
- Efficiency of the plate heat exchanger heater
- Checking of operating pressure, superheating and sub cooling
- Efficiency of compressor heater
- Cleaning of finned coil (*)
- Cleaning of fan grills
- Cleaning of condensate drain pan.

(*) For “Heat pump” appliances, the checks are to be performed quarterly.

For units installed near the sea, the intervals between maintenance should be halved.

7.3 Extraordinary maintenance

Chemical washing

Chemically wash the plate heat exchanger after every 3 years of operation.

Refrigerant gas content

The chillers are filled with R410a refrigerant gas and tested in the factory. In normal conditions, there should be no need for the Technical Assistance Service to intervene to check the refrigerant gas. However, over time, small leaks may develop at the joints leading to loss of refrigerant and draining of the circuit, causing the unit to function poorly. In this case, the leaks of refrigerant must be identified and repaired and the refrigerant circuit refilled. Proceed as follows:

- Empty and dry the entire refrigerant circuit using a vacuum pump connected to the low and high pressure tap until the vacuum meter reads about 10Pa. Wait a couple of minutes and check that this value does not rise to more than 200Pa
- Connect the refrigerant gas cylinder or a filling cylinder to the low pressure line pressure gauge connection.
- Fill with the quantity of refrigerant gas indicated on the rating plate of the unit.
- Always check the superheating and sub cooling values. In the nominal operating conditions for the appliance, these should be between 5 and 10°C and between 4 and 8°C respectively.
- After a couple of hours of operation, check that the liquid indicator indicates circuit dry (dry-green)

Important

In the event of partial leaks, the circuit must be completely emptied before being refilled

The R410a refrigerant must only be filled in the liquid state. Operating conditions other than nominal conditions may produce considerably different values.

Seal testing or identification of leaks must only be carried out using R410a refrigerant gas, checking with a suitable leak detector.

 **Prohibition**

1. The refrigerant circuit must not be filled with a refrigerant other than that indicated of specification.
2. The use of a different refrigerant may cause serious damage to the compressor.
3. Oxygen, acetylene or other inflammable or poisonous gases must never be used in the refrigerant circuit as they may cause explosion or poisoning.

7.4 Shutting down for long periods

If it is previewed not to use the machine for long periods

After deactivating the chiller:

- Make sure the remote switch SA 2 is in the "Standby" position, or alternatively disconnect the unit from the power supply.
- Make sure the remote keyboard (if present) or the ST542 is set to "OFF".
- Position QF and QS on OFF
- Deactivate the indoor terminal units by placing the switch of each unit in the "OFF" position.
- Close the water valves.

 **Important**

If there is a possibility that the outside temperature may drop below zero, there is the risk of freezing.

The water circuit **MUST BE EMPTIED AND SHUT OFF POWER** (when draining after heat pump operation take care as the water may be hot) or antifreeze must be added in the proportion recommended by the manufacturer.

8. Standard Controller

ST542

It is built-in with the chiller at the factory.



The front panel of the device functions as the user interface and is used to perform all operations relating to the device.

8.1 Introduction of Keys

There are 4 keys on the front panel. Each key has:

- A “direct” action (indicated on the key).
- An “associated” function (indicated on the front panel of the device beside the key).
- A “combined” action involving two keys.

Keys and associated functions

Key	Description key	Press once (press and release)	Key [associated function]	Press and hold [press for about 3 seconds]
	UP (UP)	<ul style="list-style-type: none"> • Increases a value • Goes to the next label 		[Manual defrost activation]
	DOWN (DOWN)	<ul style="list-style-type: none"> • Decreases a value • Goes to the previous label 		[Local ON/OFF]
	Esc(ape) Output (Without saving new settings)	<ul style="list-style-type: none"> • Exit without saving new settings • Go back to previous level 	mode	[Change mode]
	Set Confirm (save new settings)	<ul style="list-style-type: none"> • Confirms value/ exit and save new settings • Move to next level (open folder, subfolder, parameter, value) • Open State Menu 	disp	[Main display]
	ALL	Alarm acknowledgment		

8.2 Introduction of “Programming” menu and “State” menu

Programming menu

PAr	CF	Ui	St	Al	Parameters	
FnC	dEF	tA	St	CC	EUr	Functions	See Functions chapter (folder FnC)
PASS						Password	
EU	Eu00		

“States” menu

From the states menu you can view values for each resource.

For some resources, a "dynamic" view is possible.

- For example, when declared as not present / probe not configured (see System Configuration chapter

(folder Par/CF), parameter CF01=0), analogue input AI2 will not be displayed.

• For example the hours of functioning of compressor 2 - CP02 - not available on single compressor machines.

Label							Visibility	Description	Change
Ai	Ai1	Ai2	Ai3	Ai4	//	//	Dynamic	Analogue inputs	//
di	di1	di2	di3	di4	di5	//	Dynamic	Digital inputs	//
AO	AO1	AO2	AO3	//	//	//	Dynamic	Analogue outputs	//
dO	dO1	dO2	dO3	dO4	dO5	dO6	Dynamic	Digital outputs	//
CL	HOUr	dAtE	yeaR					Clock	Yes
AL	Er00	Er99	Dynamic	Alarms	//
SP	Value	//	//	//	//	//		Set points(set)	Yes
Sr	Value	//	//	//	//	//		Real set point	//
Hr	CP01	CP02	PU01	PU02	//	//	Dynamic	Running time(hours× 10) compressor/pumps	Yes

8.3 Setting Service Parameters

LIST OF ACCESSIBLE PARAMETERS		
Parameter	Description	Unit of measure
CnF*	Machine configuration parameters	value
CP	Compressor parameters	value
FAn	Fan parameters	value
ALL	Alarm parameters	value
PUP	Pump parameters	value
Fro	Frost parameters	value
dFr	Defrost parameters	value

1) Local On/OFF

Device 'ON' --->'OFF'

	<p>Press the [DOWN] key for about 3 seconds from the main display</p>
	<p>The word OFF will appear on the display. All other LEDs will be off</p>

Device 'OFF' --->'ON'



NOTE:

The local ON/OFF function is deactivated if the device has been turned OFF remotely or if a digital input is configured as a remote ON/OFF.

Remote on/standby and cooling / heating possibilities

Remote control of the unit can be done by a voltage free contact. Depending on the setting on the digital controller, the unit will operate in cooling or in heating mode.

Procedure

a. Connect the cable to the appropriate terminals as shown or the wiring diagram.

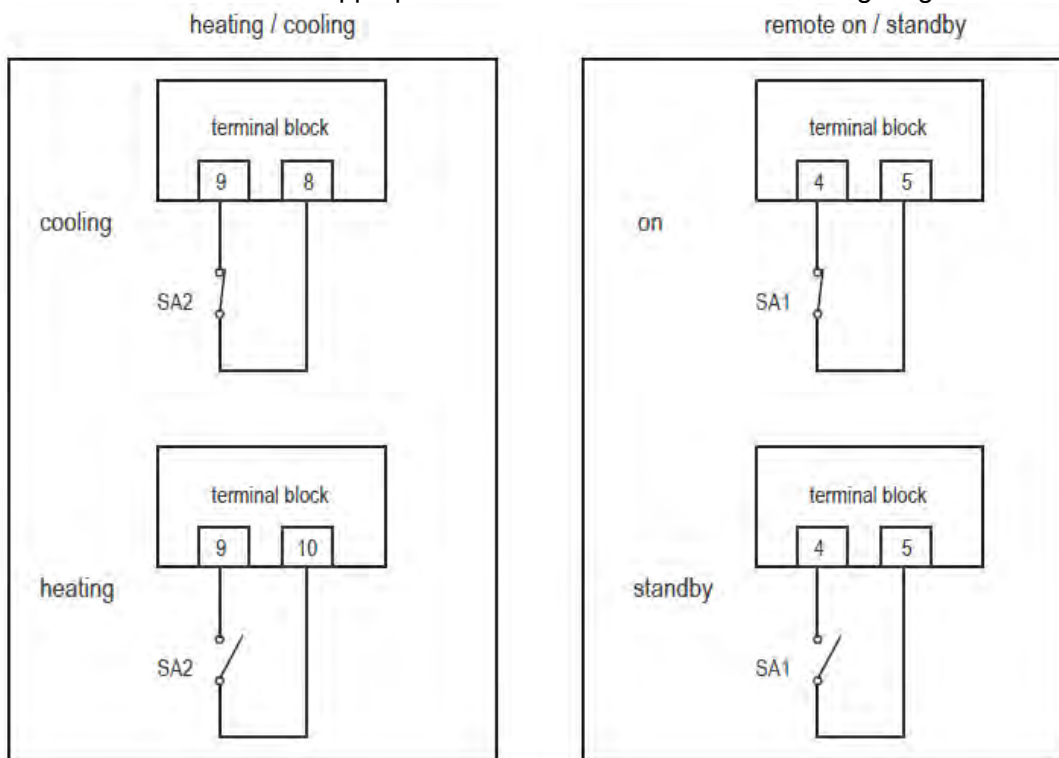

b. Fix the cable with cable ties to the cable tie mountings to ensure strain relief.

NOTE:

- ① The remote has priority and controls on/standby operation and change over operation.
- ② If you want to use ST542 to control cooling/heating neither the remote, you must to set the parameter

CF26 from “-14” to “0”.Please view parameter (folder PAr).

2) Select Operating Mode

There are three different operating modes:

- Standby mode (StbY)
- Heat mode
- Cooling mode

Instructions are provided below on how to change the operating mode.

<p>The image shows the initial display of the air conditioner. The digital display shows the time 16:45. A hand icon points to the 'mode' key on the right side of the control panel. The control panel includes 'mode', 'esc', 'set', and 'disp' buttons, along with 'Prg' and 'ABC' labels.</p>	<p>For example, let's say you want to change from StbY to COOL mode To change operating mode, press and hold the mode key for at least 2 seconds PS The main display is set as rtc (current time)</p>
<p>The display now shows 'StbY' in large digits. A hand icon points to the 'mode' key. The 'mode' key is now labeled 'mode' and the 'set' key is labeled 'disp'. The 'esc' key is labeled 'Prg'.</p>	<p>A blinking menu will open containing the values StbY (standby), HEAT (heat) and COOL (cool).</p>
<p>The display now shows 'HEAT' in large digits. A hand icon points to the 'set' key. The 'mode' key is labeled 'mode', 'esc' is 'Prg', and 'set' is 'disp'.</p>	<p>Select your required operating mode and press the set key.</p>
<p>The display now shows '0000' in large digits. A hand icon points to the 'set' key. The 'mode' key is labeled 'mode', 'esc' is 'Prg', and 'set' is 'disp'.</p>	
<p>The display returns to the main display showing the time 16:45. A hand icon points to the 'mode' key. The 'mode' key is labeled 'mode', 'esc' is 'Prg', and 'set' is 'disp'. The COOL LED is now lit.</p>	<p>You will be automatically returned to the main display and you will see that the Stby LED that was previously on has gone off and the COOL LED has come on.</p>

3) Select the Clock(CL)

	<p>To change the clock on your machine, press the set key from the main display.</p>
	<p>Pressing the set key once will open a list of the various folders. Use the "UP" and "DOWN" keys to find the CL folder.</p>
	<p>Press the set key to open the CL menu.</p>
	<p>On entering this menu, you will see HOUR. Use the "UP" and "DOWN" keys to select the time, date or year. Once you have decided what you want to set, press the [set]** key to open the modification menu for the variable selected. **press and hold for about 3 seconds</p>

4) Modifying a parameter

Instructions are provided below on how to change a machine parameter. By way of example, let's look at the CF configuration parameters folder, parameter CF26 (folder PAr/CF/CF26).

	<p>Press the esc and set keys together to open the parameters menu. This will open the PAr menu.</p>
	<p>The PAr parameters menu contains all device parameters. Press the set key to view all folders.</p>
	<p>The first folder shown for the device is the CF configuration folder. Simply press the set key again to modify individual CF parameters.</p>
	<p>The CF00 parameter will be shown on the device (factory default settings). Press the "up" key to scroll the various parameters or move to the next parameter (CF01 in this case) or the ?down? key to go back to the previous parameter (CF47 in this case). CF00->CF01->CF02->.....->CF47->CF00 CF47<-CF00<-CF01->.....<-CF46<-CF47 N.B: -> UP, <-DOWN</p>

	<p>Press the set key to view the value of the parameter (CF26 in this case).</p>
	<p>For parameter CF26, the value shown will be -14. Press the "up" and "down" keys to modify this value.</p>
	<p>Press the set key once you have entered the required value. ** Press the esc key to exit this display and go back to the previous level. **N.B. pressing the set key will confirm the value entered. Pressing the esc key will take you back to the previous level without saving the value entered.</p>

5) Set the set point(SP)

By way of example, we will change the set point value in COOL mode by 12.0 degrees centigrade to 12.5 degrees centigrade.

	<p>To change the setpoint on your machine, press the set key from the main display.</p>
--	---

<p>The remote control display shows 'A.8.8.8' in the center. Above it is a snowflake icon and the text 'ST542'. To the right are buttons labeled 'mode', 'esc', 'set', and 'disp'. A bracket groups 'esc' and 'set' as 'Prg'. On the left are 'up' and 'down' arrow buttons. Below the display are several small icons representing different modes and functions.</p>	<p>Pressing the set key once will open a list of the various folders. Use the "UP" and "DOWN" keys to scroll the menu and find the SP folder.</p>
<p>The remote control display shows 'SP.8.8' in the center. The 'set' button on the right is being pressed by a hand icon. Other buttons and icons are the same as in the previous panel.</p>	<p>Press the set key to open the SP folder.</p>
<p>The remote control display shows '0000' in the center. The 'up' and 'down' arrow buttons on the left are circled in blue. Other buttons and icons are the same.</p>	<p>The first screen you see will be the COOL mode then the HEAT mode, using the "up" and "down" keys to scroll (shown beside each view).</p>
<p>The remote control display shows 'HEAT' in the center. The 'up' and 'down' arrow buttons on the left are circled in blue. Other buttons and icons are the same.</p>	
<p>The remote control display shows '0000' in the center. The 'set' button on the right is being pressed by a hand icon. Other buttons and icons are the same.</p>	<p>Let's say you want to change the COOL mode setpoint. Select COOL from the menu, then press the set key.</p>
<p>The remote control display shows '0012.0' in the center. The 'up' and 'down' arrow buttons on the left are circled in blue. Other buttons and icons are the same.</p>	<p>The device will show the current machine setpoint, which in this case is 12.0 degrees centigrade). Use the "up" and "down" keys to increase or decrease it. For example, if you want to change the setpoint to 12.5 degrees, press the "up arrow" key until you reach the required value.</p>

	<p>Once you have reached the required setpoint, press the set key. The device will save the value 12.5.</p>
	<p>To get back to the main display, press the esc key or allow a 15 second timeout to elapse for each menu.</p>

6) View and Reset compressor/pump time

	<p>Example display and reset time (hours x10) for Pump 2 Press the set key from the main display</p>
	<p>The label Hr will appear on the display. Use the UP and DOWN keys to scroll the other labels until you find the Hr label.</p>
	<p>Press the set key to view the first label - which in this case is the running time for compressor 1 (CP01)</p>
	<p>Scroll with the UP and DOWN keys to view (if the relative resources are present) the running time for compressor 2 (CP02) the pump running time (PU01, PU02)/Press the set key to view the pump running time PU02.</p>

	<p>The tens of hours of functioning are 2. (Hours expressed in tens: 2 means 20 hours of operation). To clear pump running time PU02, press and hold the [set] key. To reset the hours of functioning of pump PU02, press and hold [set]. Note: Repeat the procedure described to reset the hours of functioning of the other resources.</p> <p>-----</p> <p>Press the esc key to go back to the main display.</p>
--	---

7) Reset alarm log (folder EUr)

Press [esc + set] in the main screen.
 The label 'PAR' will appear. Scroll with 'UP' and 'DOWN' to find the 'FnC' label. Press 'set'. The label 'dEF' will appear. Scroll with 'UP' and 'DOWN' to find the 'EUr' label.

	<p>Press the "set" key for 3 seconds [set]</p>
	<p>The 'YES'= label appears to indicate that the alarm log has been deleted.</p>

Keys-combined action

Symbol [function associated to the combined pressing of the keys]	Combination Keys	Combined pressing of keys Press once (press and release)	[associated function]	[Menu] / Comments		
		<p>[UP (UP) + DOWN (DOWN)]</p>	<p>[Manual reset]</p>	<p>See Manual alarm acknowledgment and reset section</p>		
						<p>[Esc+SETPOINT]</p>
		<p>[Esc+SETPOINT]</p>		<p>[Open programming menu]</p>	<p>[Programming menu]</p>	

8) Manual alarm acknowledgment and reset

Alarm messages blink. How to acknowledge an alarm is explained below.
All error messages are shown in the AL folder (see state Menu)

	<p>An error message will be shown, alternating with the error alert and the main display. The ALARM LED will be permanently on.</p>
	<p>An error can be acknowledged by pressing any key once. After pressing any key, the alarm LED will start to blink.</p>
	<p>MANUAL RESET</p> <p>To manually reset an alarm, press the “up” and “down” keys together [UP+DOWN]</p> <p>-----</p> <p>N.B: resetting an active alarm* will save the alarm in the AL folder (see state Menu). * i.e. manual reset (alarm)</p>

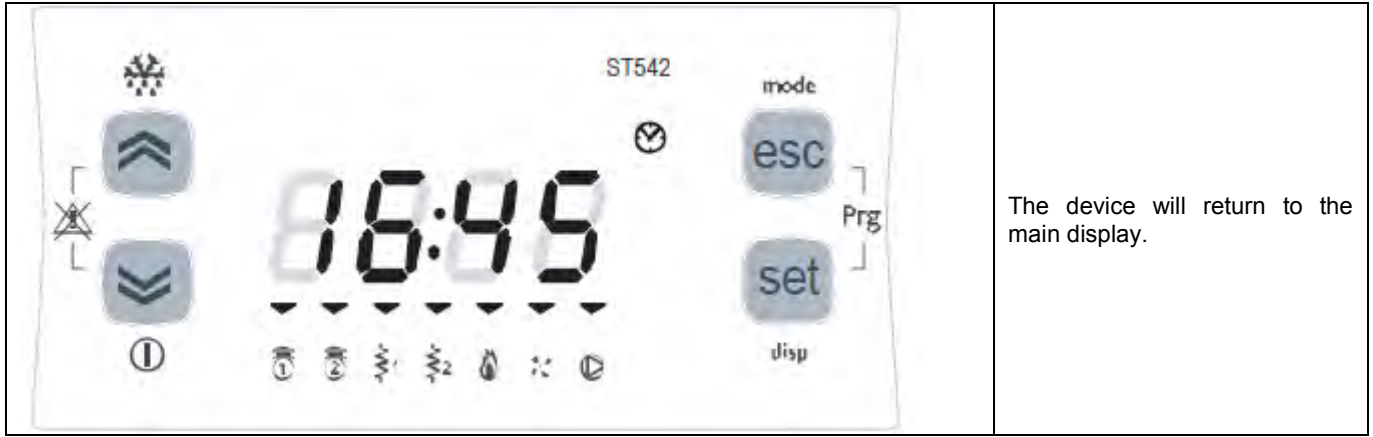

9) LEDs and Display

The display has 18 icons (LEDs) split into 3 categories (+ decimal point):

- Decimal point
- States and Operating Modes
- Values and Units of Measure
- Loads

Display

Values of up to 4 figures or 3 figures plus a sign can be displayed.

LED: decimal point

Values are always shown in tenths of a degree/bar.



At every change of season, make sure the operating conditions fall within the limits specified in the table of technical data. Check that the compressor current input is less than the maximum indicated in the table of technical data. In three-phase models, check that the noise levels of the compressor are not abnormal. If this is the case, reverse one phase. Make sure the voltage is within the established limits and that, for three phase units, the unbalance between the phases is less than 3%. Check that the cover is closed again following the setting procedure. Heating and cooling are activated and deactivated via the control panel.

10) Alarm Display (AL)

	<p>Press the set key from the main display</p>
	<p>The label A_i will appear on the display. Use the UP and DOWN keys to scroll the other labels until you find the AL label</p>
	<p>Press the set key to view the label of the first active alarm (if it exists)</p>
	<p>In this case, the first alarm is Er01. Use the UP and DOWN keys to scroll any other alarms. N.B: the menu is not cyclical. For example, if the active alarms are ER01, Er02 and Er03, the display will show: Er01 ->Er02->Er03 <-Er02<-Er01 N.B: -> UP, <-DOWN Press the esc key to go back to the main display.</p>

9. Optional controller

SKW 210 LCD remote controller:

It connects with ST542 to realize long-distance control. Absolutely same function with the controller that built-in with the chiller.



Display:

4 figure display to show

- time(hh: mm)
- menu label
- parameters label
- alarms label

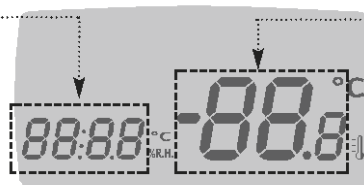

Display with 2 1/2 figures + sign to show

- temperature / pressure
- parameters folders
- parameters value

Technical data:

- Front protection: IP30.
- Container: PC+ABS UL94 V-0 resin plastic casing , polycarbonate cover, rubber keys with conductive carbon pads.
- Dimensions: 137x96.5x31.3mm.
- Mounting: wall mounting.
- Working temperature: -5~60°C.
- Storage temperature: -10~70°C.
- Operating & Storage humidity: 10~90%RH.
- Power draw: 500mW max.

User interface:

- Keys: 4 keys on the front panel of the instrument.
- Display: LCD.
- Icons: 16 icons on the display, 9 icons on the front panel.
- Double display to show temperatures /menu / folders/ parameters.

a) 4 figures.

b) 2 and a half figures + sign.

Dimension:

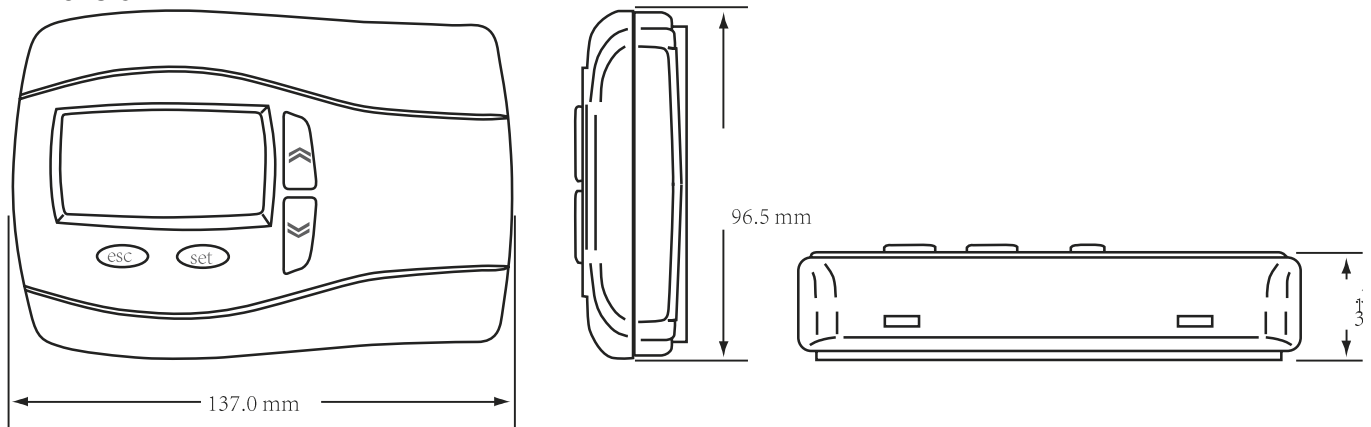

Installation

The device is designed to be fitted on the wall.

Open the front panel of the appliance, separating it from the bottom, levering it with a screwdriver or similar tool (see figure 1). After having removed the front the panel, make 2 holes with diameter 4 mm on the wall to which the device is to be fixed, at the required distance (see figure 3 point A).

Now position the bottom of the device on the wall with the two screws.

After having made the connections, close the front panel of the keypad by pressing it with your fingers (figure 2).

The admissible ambient temperature range for correct operation is between -5 and 60 °C.

Also avoid fitting the device in places where there is high humidity and/or dirt; it is suitable for use in environments with an ordinary or normal level of pollution. Keep the area around the device's cooling slots adequately ventilated.

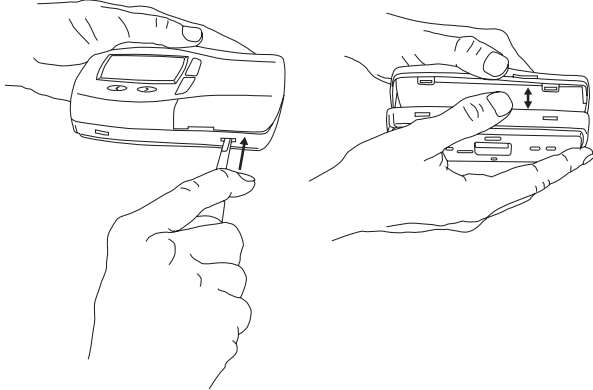

Figure 1

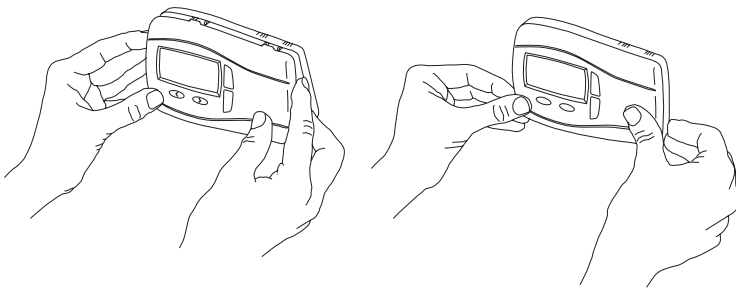

Figure 2

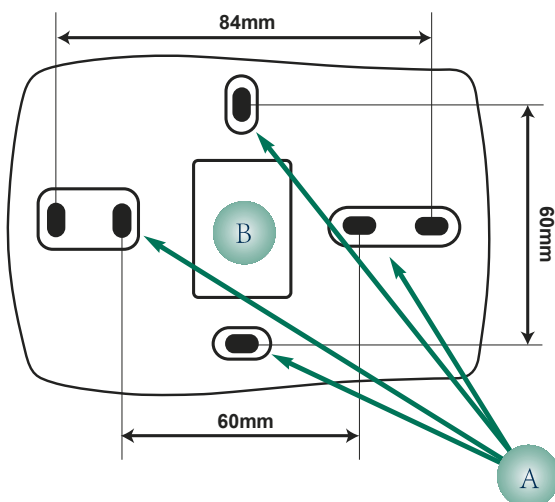

Figure 3

Electrical connection

Switch the device OFF before working on the connections.

All electric work must be performed by a qualified electrician.

The connection is made through (see connections SKW210-ST542):

- Screw connector for the connection with ST542 or alternatively (see connections SKW210-ST542)
- JST 3-way connector for connection with ST542 present inside the front panel and accessed by removing the cover (using a screwdriver or similar tool) as illustrated in figure 1.

The cables must pass through the hole in the center of the rear (figure 3 point B)

Make sure that the power supply is the correct voltage for the device.

If the device is fitted on a metal panel, the panel must be earthed.

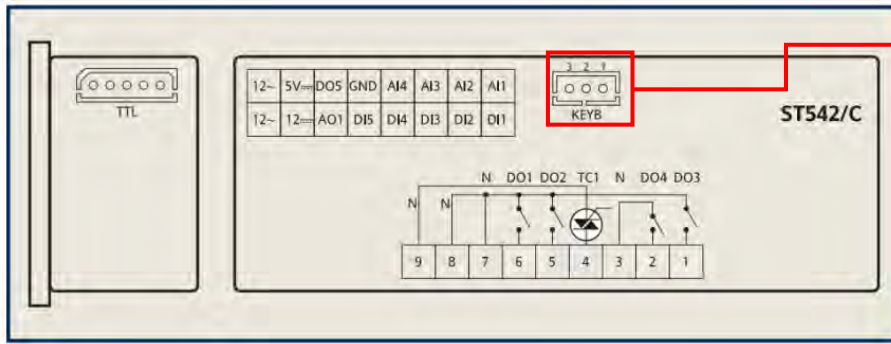

ST542

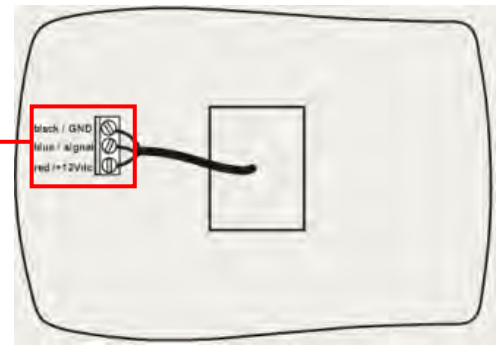

SKW210



Air Conditioning Systems

Cooling & Heating

TRUST AIR-CONDITIONING EQUIPMENT CO.

Shiraz office: 8 th floor, Alvand Blog., Dostan St.,
Moaliabad Ave., SHIRAZ, IRAN., Post code: 71877-14446

Tel.: +98-71-36341070

Fax.: +98-71-36341094

Tehran office: No. 19- koohe nour St.- Motahhari St.-

TEHRAN, IRAN., Post code: 15876-73111

Tel.: +98-21-89389

Fax.: +98-21-88541903

Ahwaz office: No. 309- Kaveh St.- AHWAZ, IRAN., Post code: 61939-
47911

Tel.: +98-61-32230647-8

Fax.: +98-61-32230647

E-mail: info@trustacs.com

Web site: <http://www.trustacs.com>

پرتو پرتو در اولین جشنواره بین المللی
برترین نام و نشان های تجاری ایران

