

# INVERTER DUCT SPLIT



---

TRUST AIR CONDITIONING EQUIPMENT CO.  
Prepared By: Engineering & R & D Department.

<b>Part 1 General Information .....</b>	<b>2</b>
<b>Part 2 Indoor Units .....</b>	<b>4</b>
<b>Part 3 Outdoor.....</b>	<b>18</b>

**توجه:**

**شرکت تراست حق تغییر مشخصات دستگاه‌ها را در جهت بهبود و ارتقای کیفیت برای خود محفوظ می‌دارد.**

2016

# Part 1

## General Information

<b>1. External Appearance .....</b>	<b>3</b>
<b>1.1 Indoor Units.....</b>	<b>3</b>
<b>1.2 Outdoor Units.....</b>	<b>3</b>

# 1. External Appearance

## 1.1 Indoor Units

Duct



## 1.2 Outdoor Units

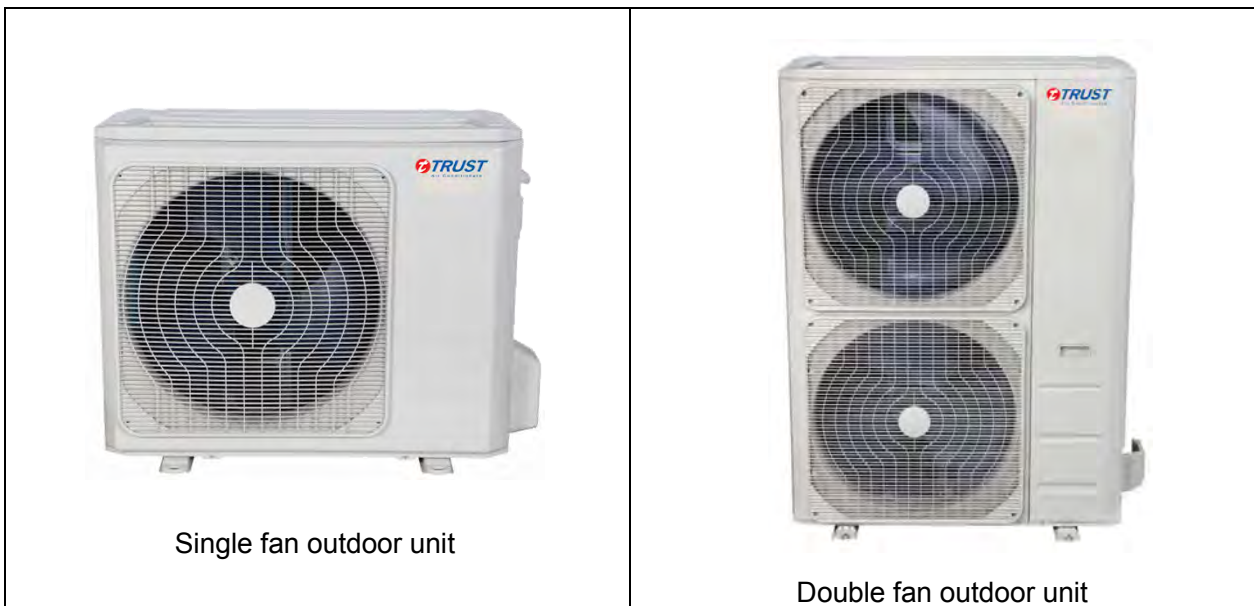

Single fan outdoor unit

Double fan outdoor unit

# **Part 2**

# **Indoor Units**

## **Duct Type**

# Duct Type

<b>1.Features .....</b>	<b>6</b>
<b>2.Dimensions .....</b>	<b>10</b>
<b>3.Service Space .....</b>	<b>11</b>
<b>4. Wiring Diagrams .....</b>	<b>12</b>
<b>5. Electric Characteristics .....</b>	<b>13</b>
<b>6.Sound Levels .....</b>	<b>14</b>
<b>7. Accessories.....</b>	<b>15</b>
<b>8.The Specification of Power .....</b>	<b>16</b>
<b>9. Field Wiring .....</b>	<b>17</b>

# 1. Features

## 1.1 Higher Static Pressure

- As a ducted air conditioner with medium static pressure, it has the widest static pressure range.
- The maximum static pressure reaches 160 Pa



## 1.2 Slim Design

- The industry Lowest height is designed to be fitted into tight roof spaces.
- \*18K unit - 210mm, 24K/36K unit - 249mm, 48K unit - 300mm

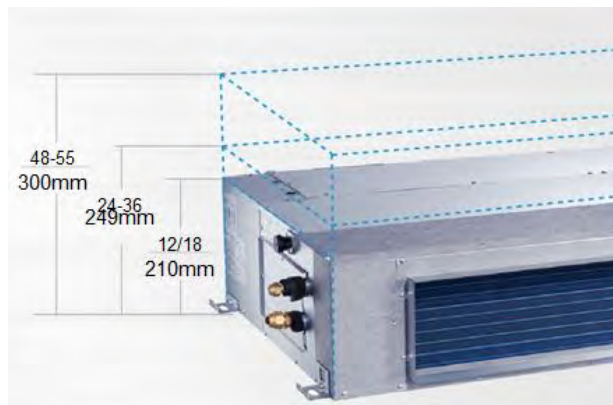

## 1.3 Constant air volume control

- For ordinary duct, when the static pressure exceeds the expected range, it is fairly difficult even for an experienced installer to calculate and adjust the air volume precisely.
- With constant air volume control technology, the duct will automatically adjust to perfect static pressure and keep constant air volume.

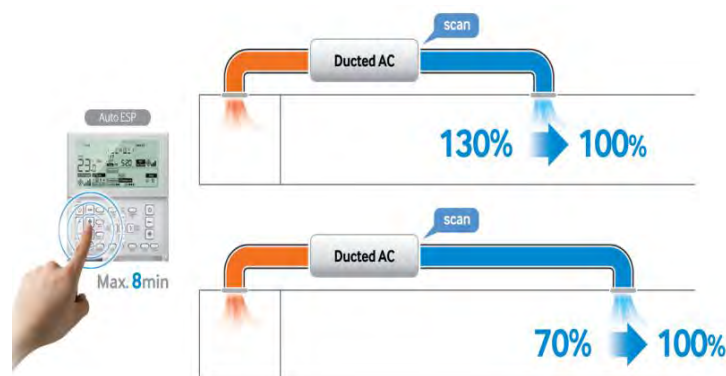

## 1.4 Installation accessories: (Optional)

- Front Board, Canvas Air Passage, Filter, Panel, for easy installation

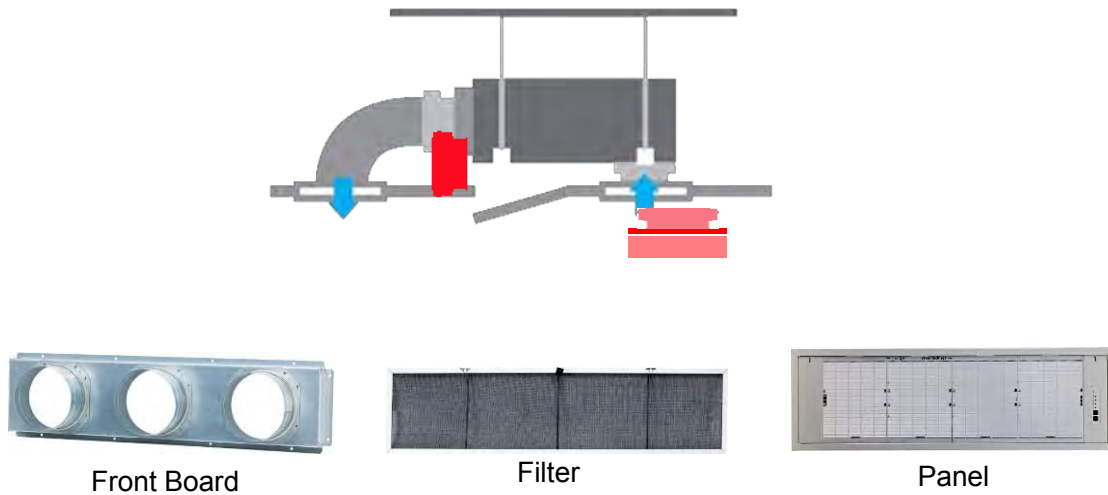

### 1.5 Flexible Air Intake Way (Bottom side or Rear side)

- The frame size of air inlet in rear and bottom is the same. It's very easy to switch to match different application.

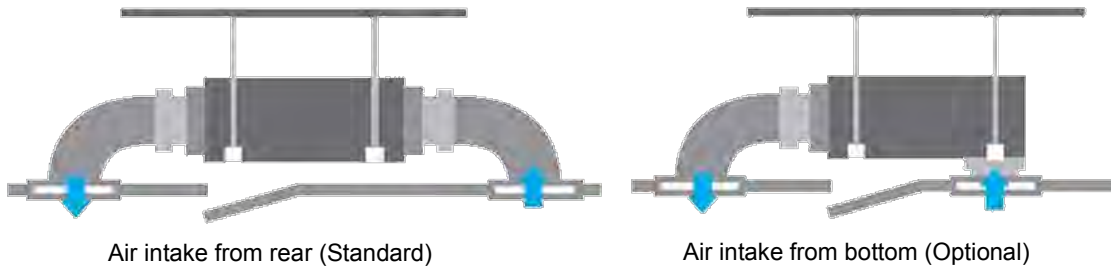

### 1.6 Communication wire connection

- A6 duct uses two wires without polarity connection way, which almost has no mistake during the installation.



### 1.7 Easy Clean

- Clean the filter (Optional, standard product without filter)
- It is easy to draw out the filter from the indoor unit for cleaning, even the filter is installed in rear side or bottom side.



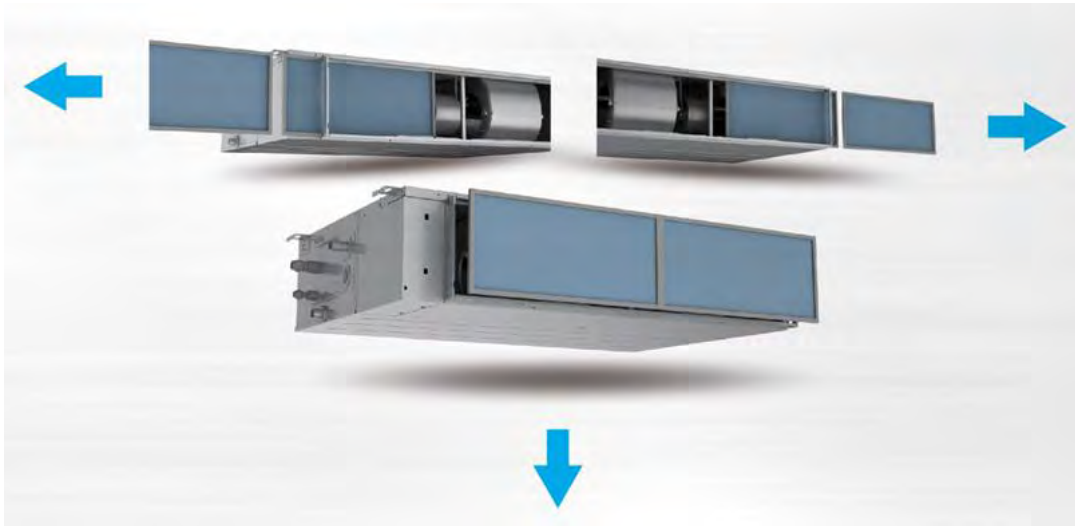

- With a larger window design, once the motor and the blower wheels have been detached, heat exchanger and water receiver tray in behind can be seen very clearly. Dust can be easily removed from the inside by vacuum



### 1.8 Easy maintenance

- A6 duct allows operators maintenance the motor from the bottom more easily compare with that on the top.

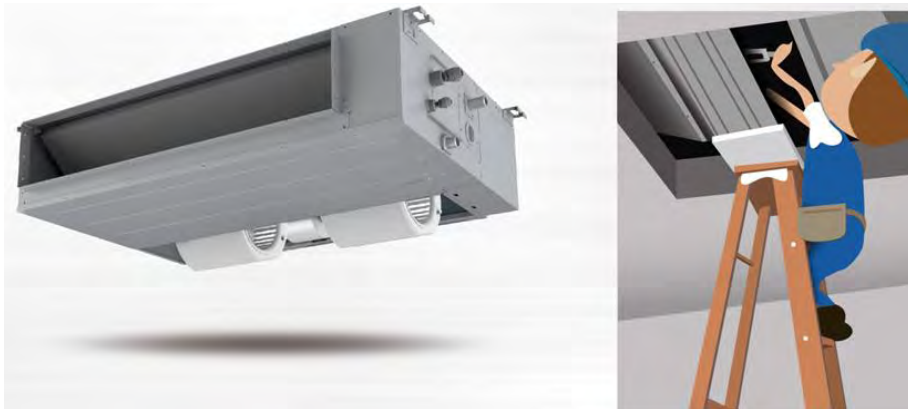

- A6 duct has big space for maintenance at the side

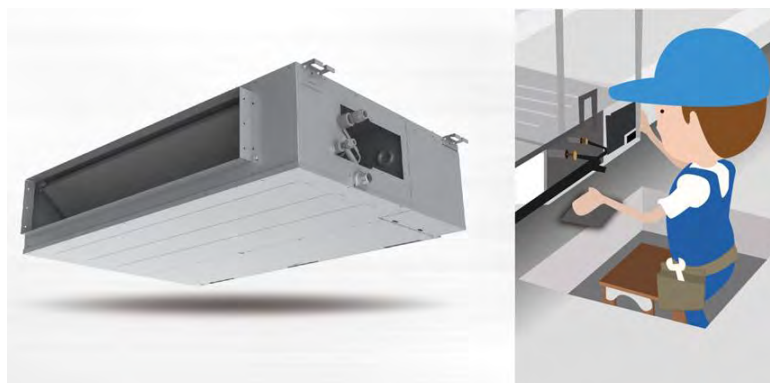

### 1.9 Twins Function

- The twin system connects two indoor units of the same type and capacity to one outdoor unit in order to ensure more air distribution in a large zone. The controller can only control the master unit. The slave unit will work in the same state as the master unit.

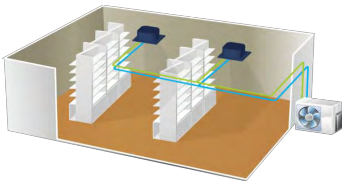

	Outdoor Unit	Indoor Units
Twin System	36K	18K + 18K
	48K	24K + 24K
	60K	30K + 30K

### 1.10 Fresh air intake function(Optional)

- Install one duct from the reserved fresh-air intake to outdoor. Continually inhale the fresh air to improve the quality of the indoor air, fulfills air quality more healthy and comfortable.
- A ventilation motor (provided by the installer) can be installed inside the fresh air duct to improve the fresh air volume. There are reserved ports for this motor on main PCB (Standard for 3D inverter units, and only optional for DC inverter 53~160 units).

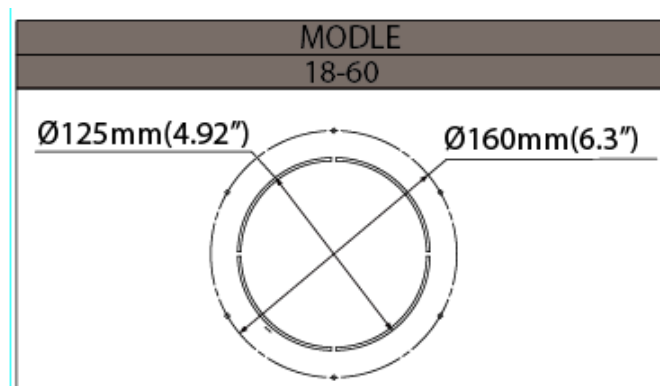

### 1.11 Built-in drain pump (Optional)

- Built-in drain pump can lift the water to 750mm upmost, which widens the drainage piping range.

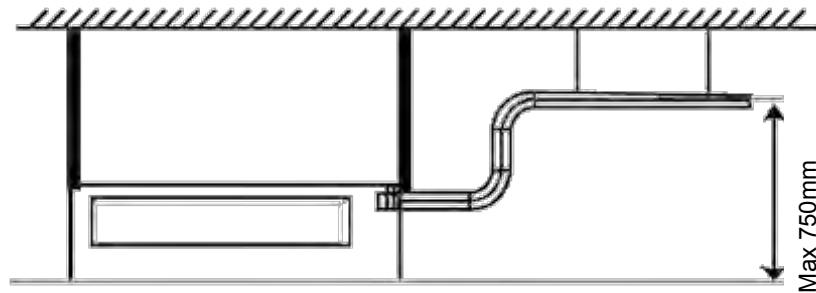

## 2. Dimensions

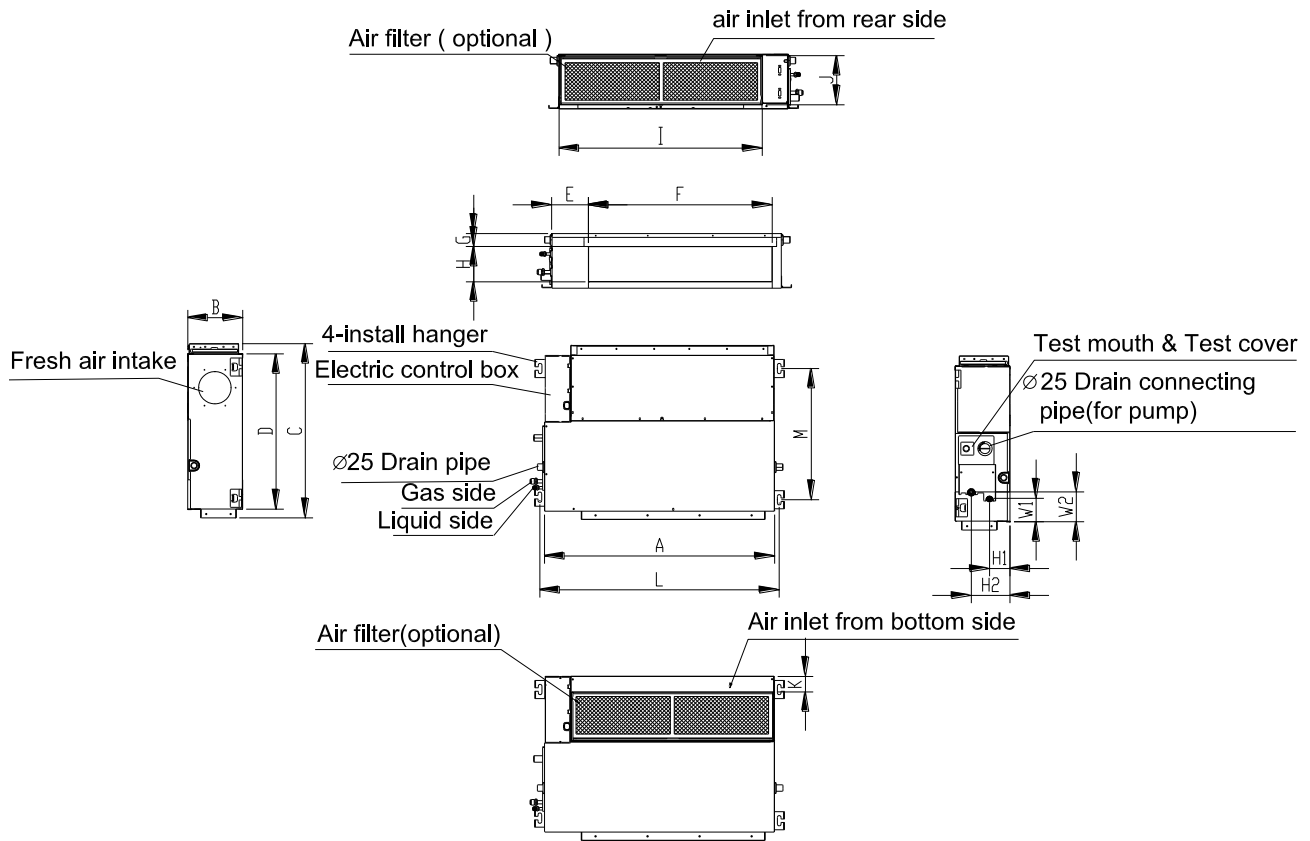

Model (KBtu/h)	unit	A	B	C	D	E	F	G	H	I	J	K	L	M	H1	H2	W1	W2
18	mm	880	210	674	600	140	706	50	136	782	190	40	920	508	78	148	88	112
	inch	34.65	8.27	26.54	23.62	5.51	27.80	1.97	5.35	30.79	7.48	1.57	36.22	20.00	3.07	5.83	3.46	4.41
24	mm	1100	249	774	700	140	926	50	175	1001	228	5	1140	598	80	150	130	155
	inch	43.31	9.80	30.47	27.56	5.51	36.46	1.97	6.89	39.41	8.98	0.20	44.88	23.54	3.15	5.91	5.12	6.10
30/36	mm	1360	249	774	700	140	1186	50	175	1261	228	5	1400	598	80	150	130	155
	inch	53.54	9.80	30.47	27.56	5.51	46.69	1.97	6.89	49.65	8.98	0.20	55.12	23.54	3.15	5.91	5.12	6.10
42/48/55	mm	1200	300	874	800	123	1044	50	227	1101	280	5	1240	697	80	150	185	210
	inch	47.24	11.81	34.41	31.5	4.84	41.1	1.97	8.94	43.35	11.02	0.20	48.82	27.44	3.15	5.91	7.28	8.27

### 3. Service Space

Ensure enough space required for installation and maintenance.

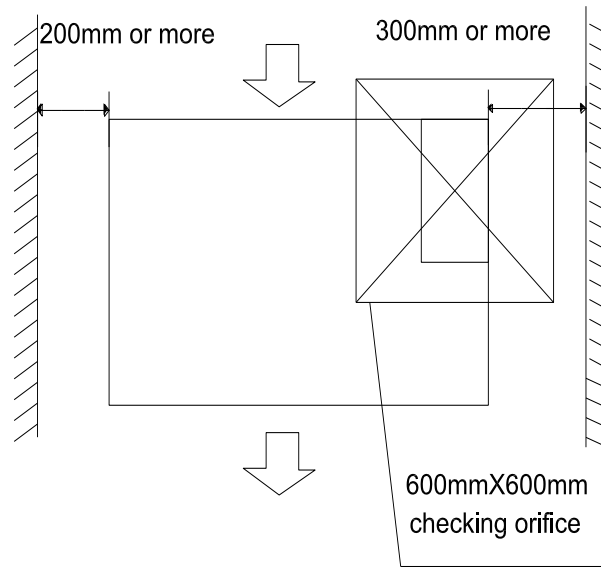

## 4. Wiring Diagrams

TMSI18HT1<sup>3.22</sup>/(O)4SD1R1Y0S, TMSI24HT1<sup>3.24</sup>/(O)4SD1R1Y0S, TMSI30HT1<sup>3.24</sup>/(O)4SD1R1Y0S  
TMSI36HT1<sup>3.25</sup>/(O)4SD1R1Y0S, TMSI48HT1<sup>3.21</sup>/(O)4SD2R1Y0T, TMSG60HT1<sup>3.42</sup>/(O)4SD2R1Y0T

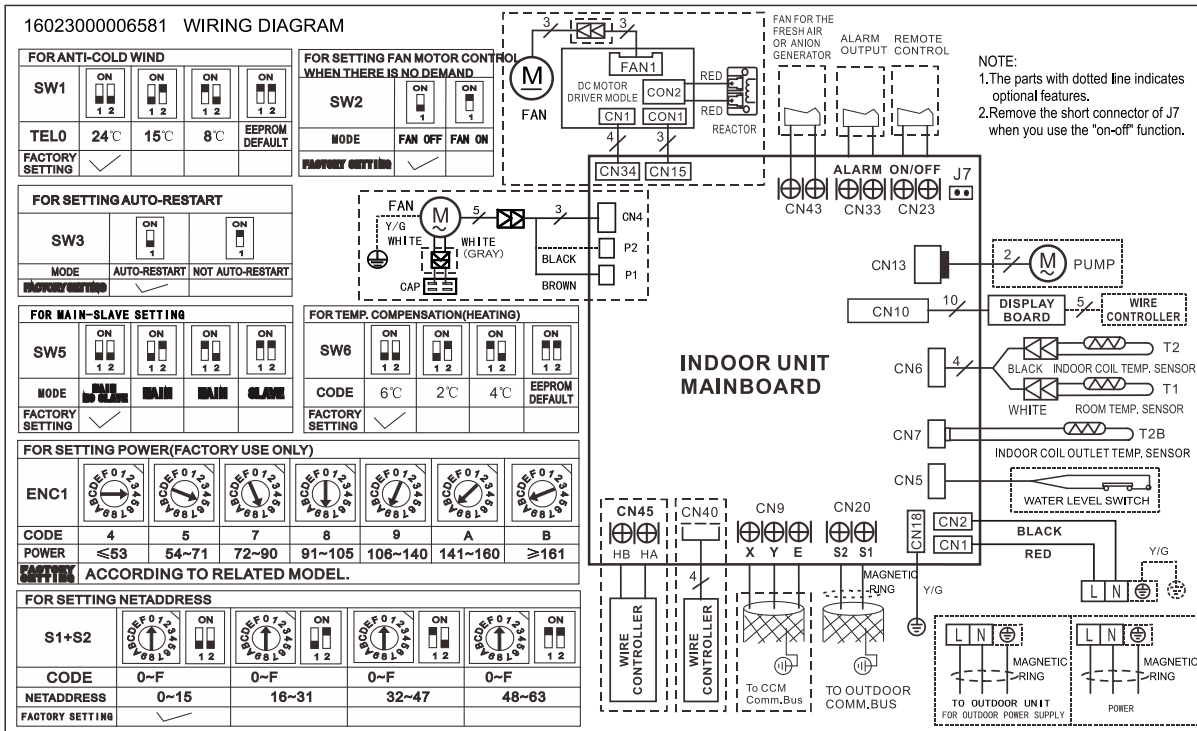

## 5. Electric Characteristics





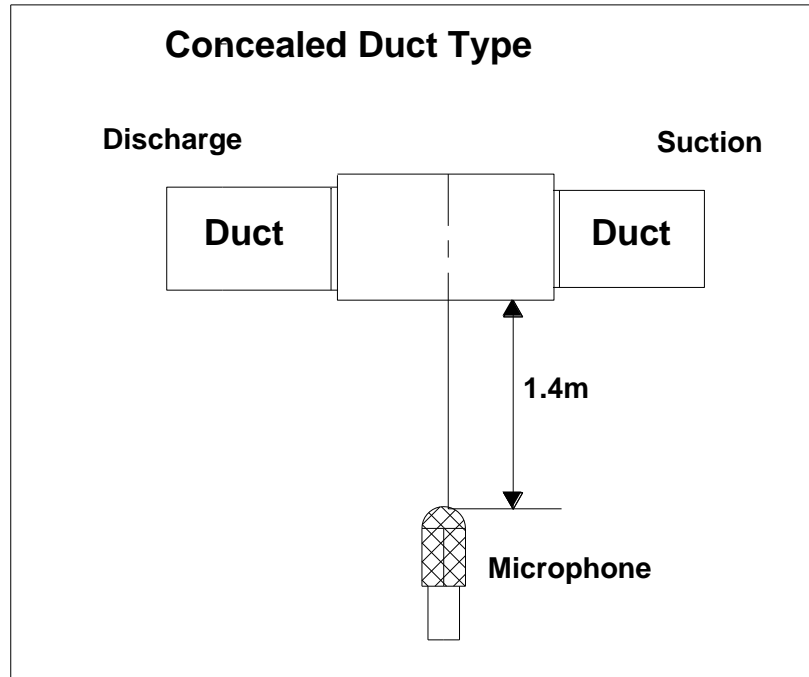





Model	Indoor Unit				Power Supply
	Hz	Voltage	Min.	Max.	MFA
TMSI18HT1 <sup>3.22</sup> /I(O)4SD1R1Y0S	50	220-240	198	254	/
TMSI24HT1 <sup>3.24</sup> /I(O)4SD1R1Y0S	50	220-240	198	254	/
TMSI30HT1 <sup>3.24</sup> /I(O)4SD1R1Y0S	50	220-240	198	254	/
TMSI36HT1 <sup>3.25</sup> /I(O)4SD1R1Y0S	50	220-240	198	254	/
TMSG60HT1 <sup>3.42</sup> /I(O)4SD2R1Y0T	50	220-240	198	254	/
TMSI48HT1 <sup>3.21</sup> /I(O)4SD2R1Y0T	50	220-240	198	254	/

## 6. Sound Levels



Model	Sound Power dB(A)	Noise level dB(A)		
		H	M	L
TMSI18HT1 <sup>3.22</sup> /I(O)4SD1R1Y0S	58	42	40	38
TMSI24HT1 <sup>3.24</sup> /I(O)4SD1R1Y0S	62	42	39	36
TMSI30HT1 <sup>3.24</sup> /I(O)4SD1R1Y0S	63	41	40	37
TMSI36HT1 <sup>3.25</sup> /I(O)4SD1R1Y0S	62	42	40	39
TMSI48HT1 <sup>3.21</sup> /I(O)4SD2R1Y0T	71	52	50	48
TMSG60HT1 <sup>3.42</sup> /I(O)4SD2R1Y0T	75	57	56	54

## 7. Accessories

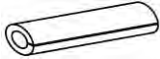
	Name	Shape	Quantity
<b>Tubing &amp; Fittings</b>	Soundproof / insulation sheath		2
	<b>Drainpipe Fittings (for cooling &amp; heating)</b>	Drain joint	
	Seal ring		1
EMC & It's Fitting (for some models)	Magnetic ring (twist the electric wires L and N around the magnetic ring to five circles)		1
<b>Wired controller &amp; Its Frame</b>	Wired controller		1
	Owner' s manual of wired controller		1
	Wired controller installation manual		1
<b>Others</b>	Owner' s manual		1
	Installation manual		1
	Connecting wire for display (2m)		1(on some models)
	Cord protection rubber ring		1(on some models)



## 8. The Specification of Power

Model(Btu/h)		18000-24000	30000	36000	36000
POWER	Phase	1-phase	1-phase	1-phase	3-phase
	Frequency and Voltage	220-240V, 50Hz	220-240V, 50Hz	220-240V, 50Hz	380-415V, 50Hz
	POWER WIRING (mm <sup>2</sup> )	3×2.5	3×2.5	3×4.0	5×2.5
CIRCUIT BREAKER/Fuse (A)		30/20	40/30	40/30	30/20
Indoor/Outdoor Connecting Wiring (Weak Electric Signal) (mm <sup>2</sup> )		2×0.2	2×0.2	2×0.2	2×0.2
Indoor/Outdoor Connecting Wiring (Strong Electric Signal)(mm <sup>2</sup> )		3×1.0	3×1.0	3×1.0	3×1.0

Model(Btu/h)		42000~48000	42000-60000
POWER	Phase	1-phase	3-phase
	Frequency and Voltage	220-240V, 50Hz	380-415V, 50Hz
	Power Wiring (mm <sup>2</sup> )	3×4.0	5×2.5
Circuit Breaker/Fuse(A)		40/35	30/25
Indoor/Outdoor Connecting Wiring(Weak Electric Signal) (mm <sup>2</sup> )		2×0.2	2×0.2
Indoor/Outdoor Connecting Wiring(Strong Electric Signal) (mm <sup>2</sup> )		3×1.0	3×1.0

## 9. Field Wiring

### Air Condition Link-Circuit

16023000006042

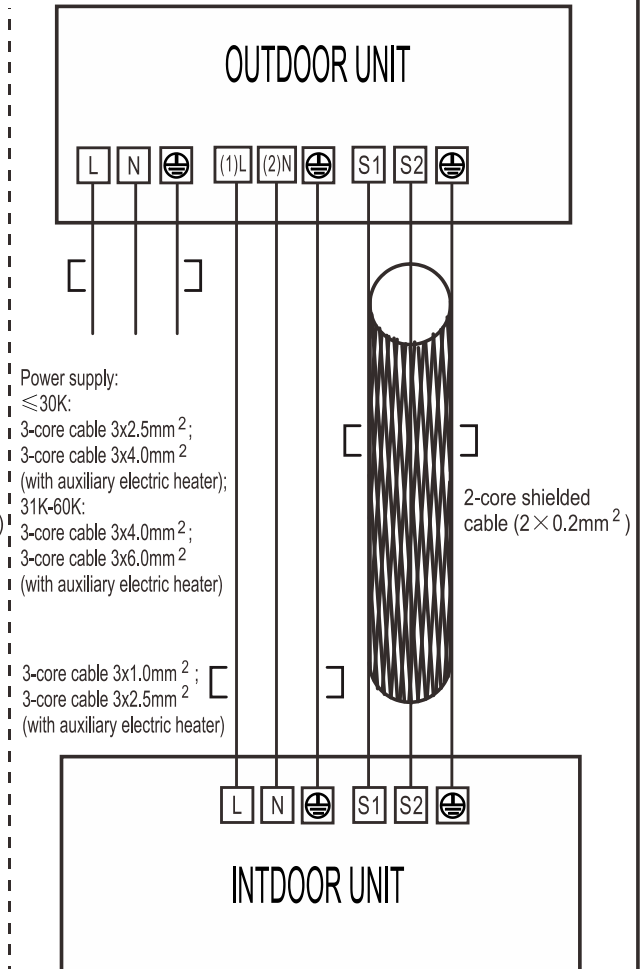
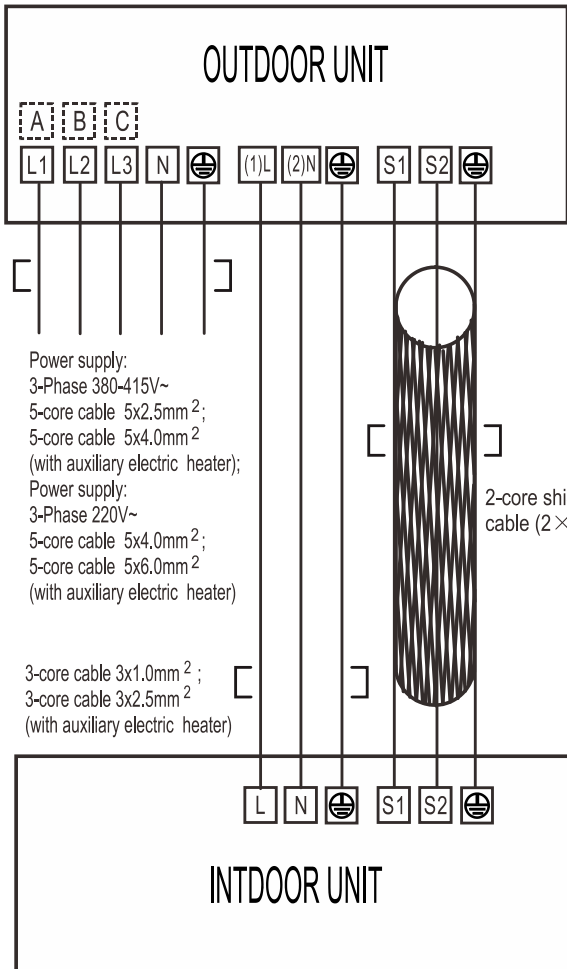

---

# Part 3

## Outdoor Units

1. Dimensions.....	19
2. Service Space.....	21
3. Wiring Diagrams .....	22
4. Piping Diagrams.....	26
5. Electric Characteristics .....	27
6. Operation Limits .....	28
7. Sound Levels.....	29

# 1. Dimensions

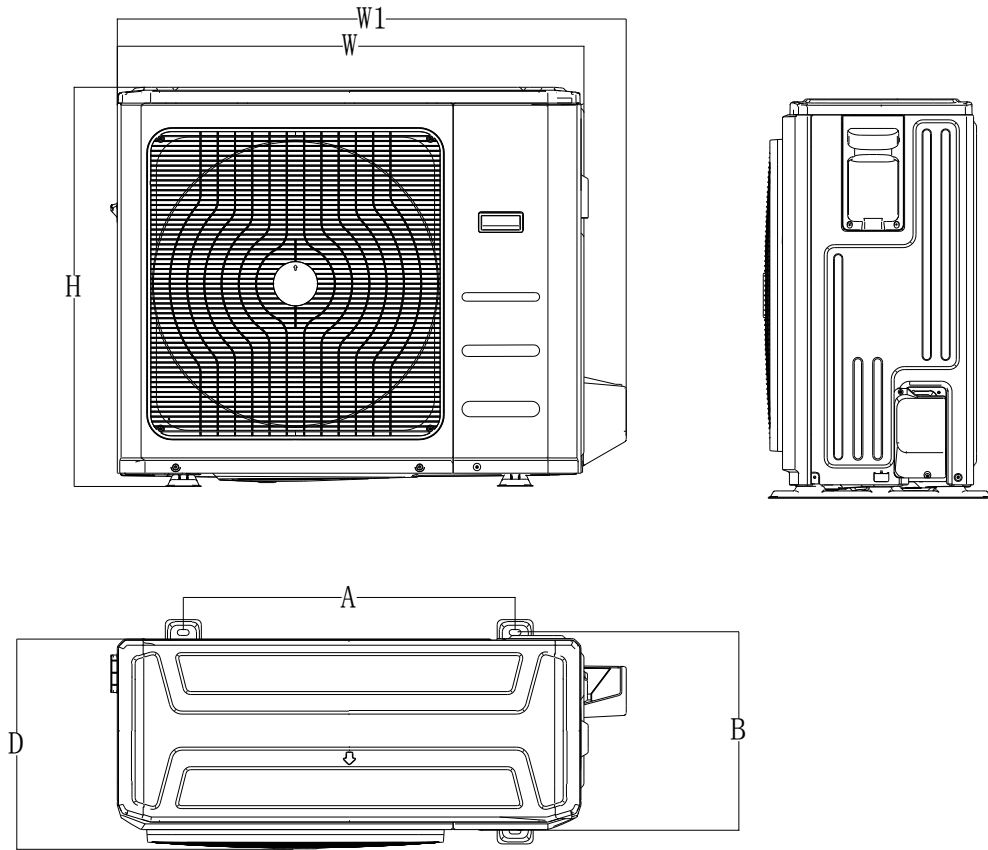

Model(KBtu/h)	Unit: mm					
	W	D	H	W1	A	B
18	800	333	554	870	514	340
24	845	363	702	914	540	350
30/36	946	410	810	1030	673	403

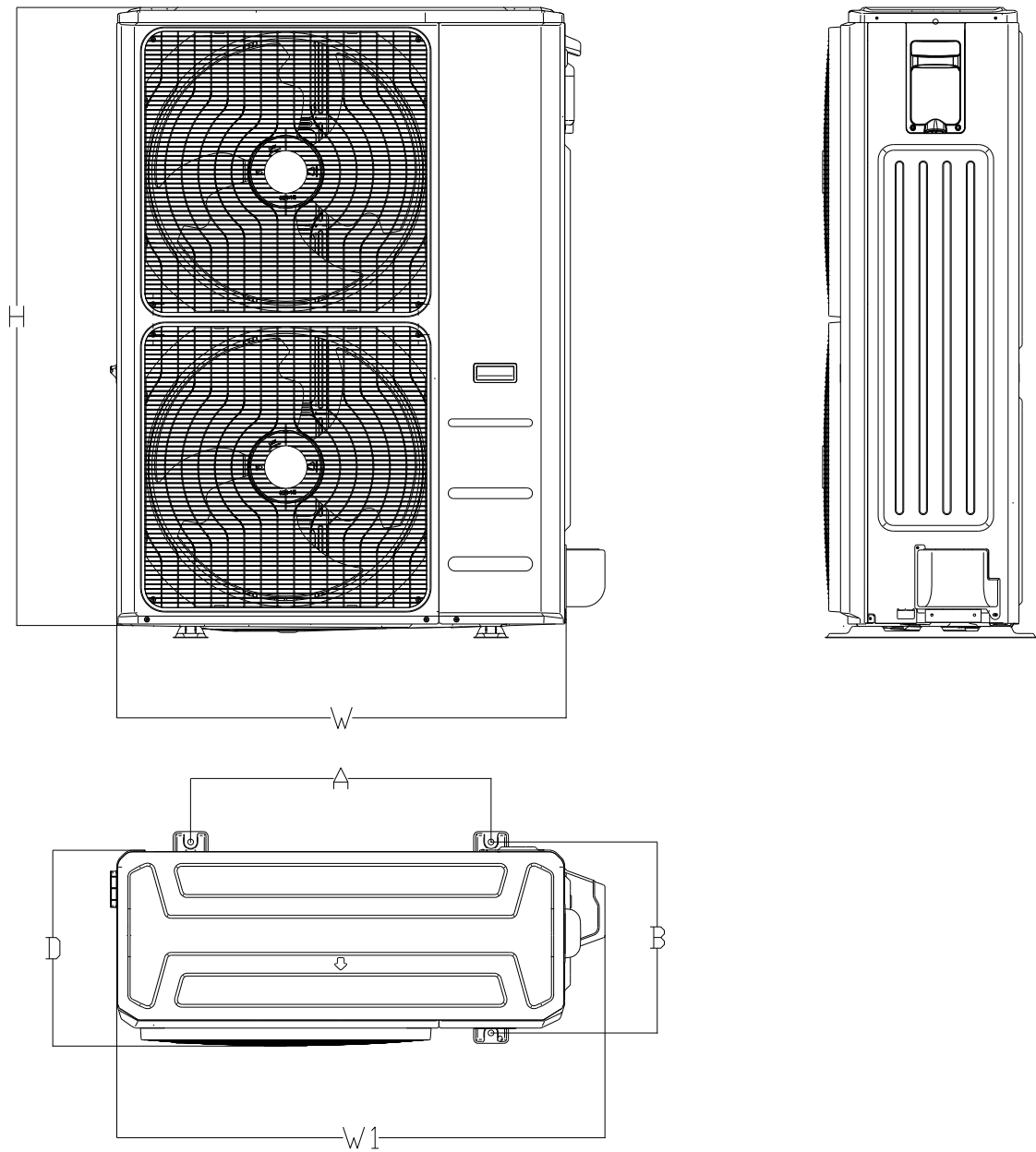

Model(KBtu/h)	Unit: mm					
	W	D	H	W1	A	B
48/60	952	415	1333	1045	634	404

## 2. Service Space

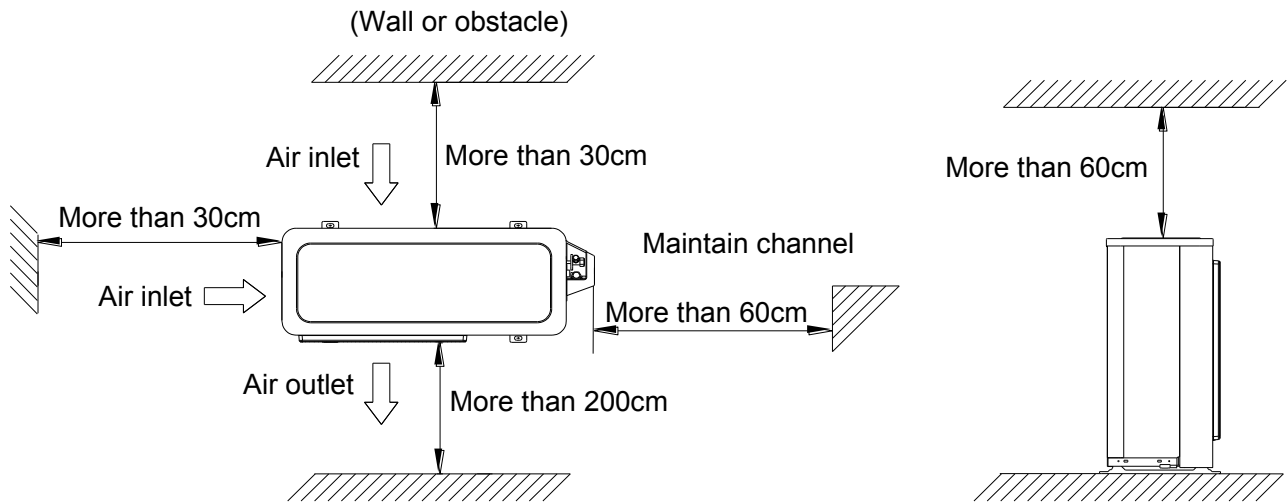

### 3. Wiring Diagrams

**TMSI18HT1I<sup>3.22</sup>/I(O)4SD1R1Y0S**

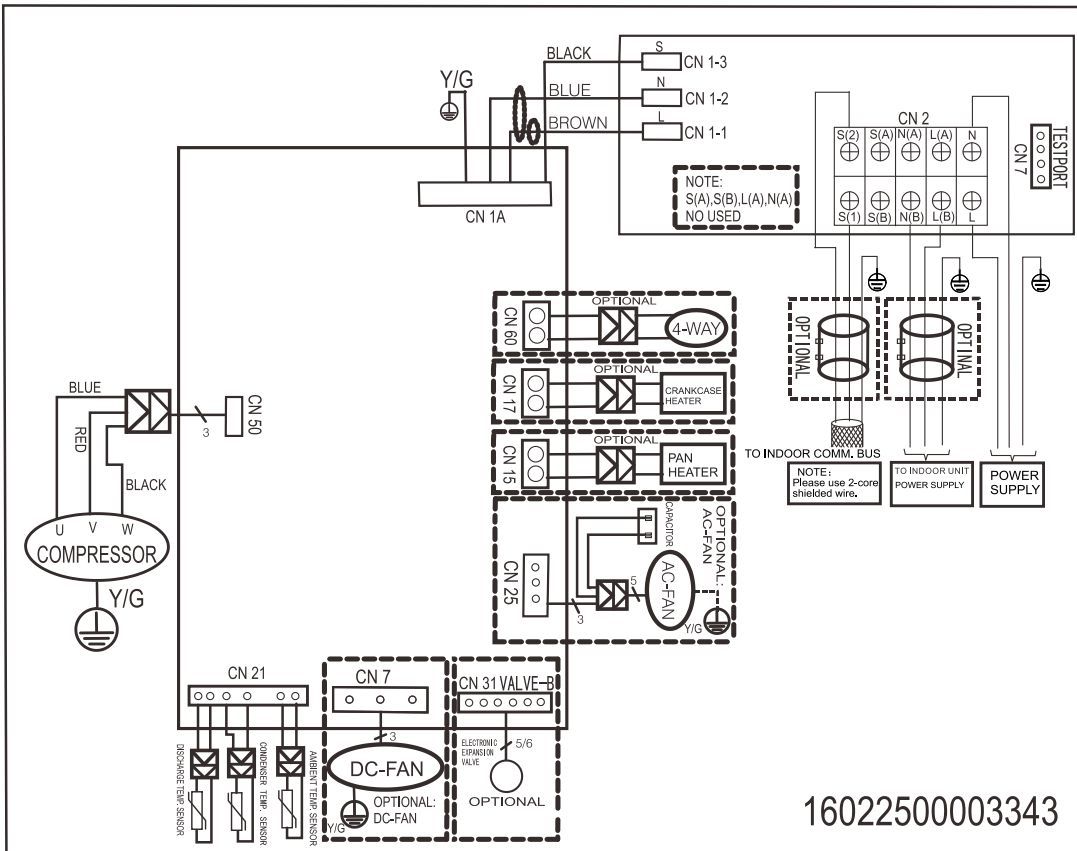

**TMSI24HT1<sup>3.24</sup>/I(O)4SD1R1Y0S, TMSI30HT1<sup>3.24</sup>/I(O)4SD1R1Y0S**

16022500003003

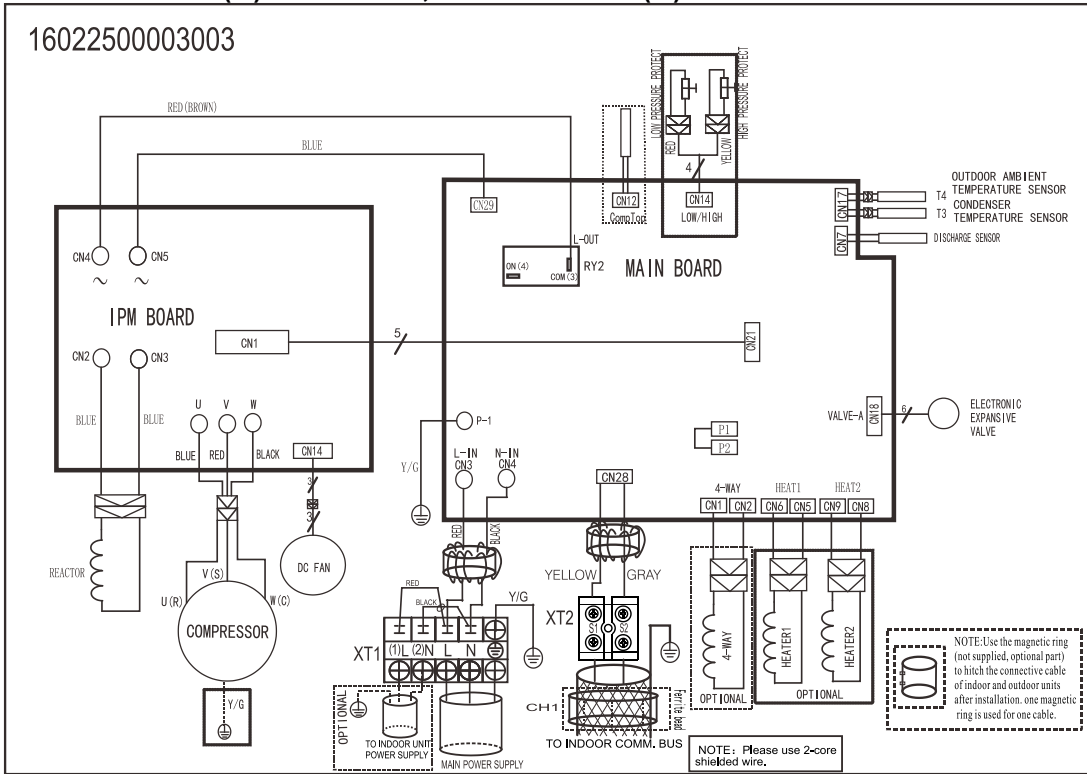



**TMSI36HT1I<sup>3.25</sup>/I(O)4SD1R1Y0S**

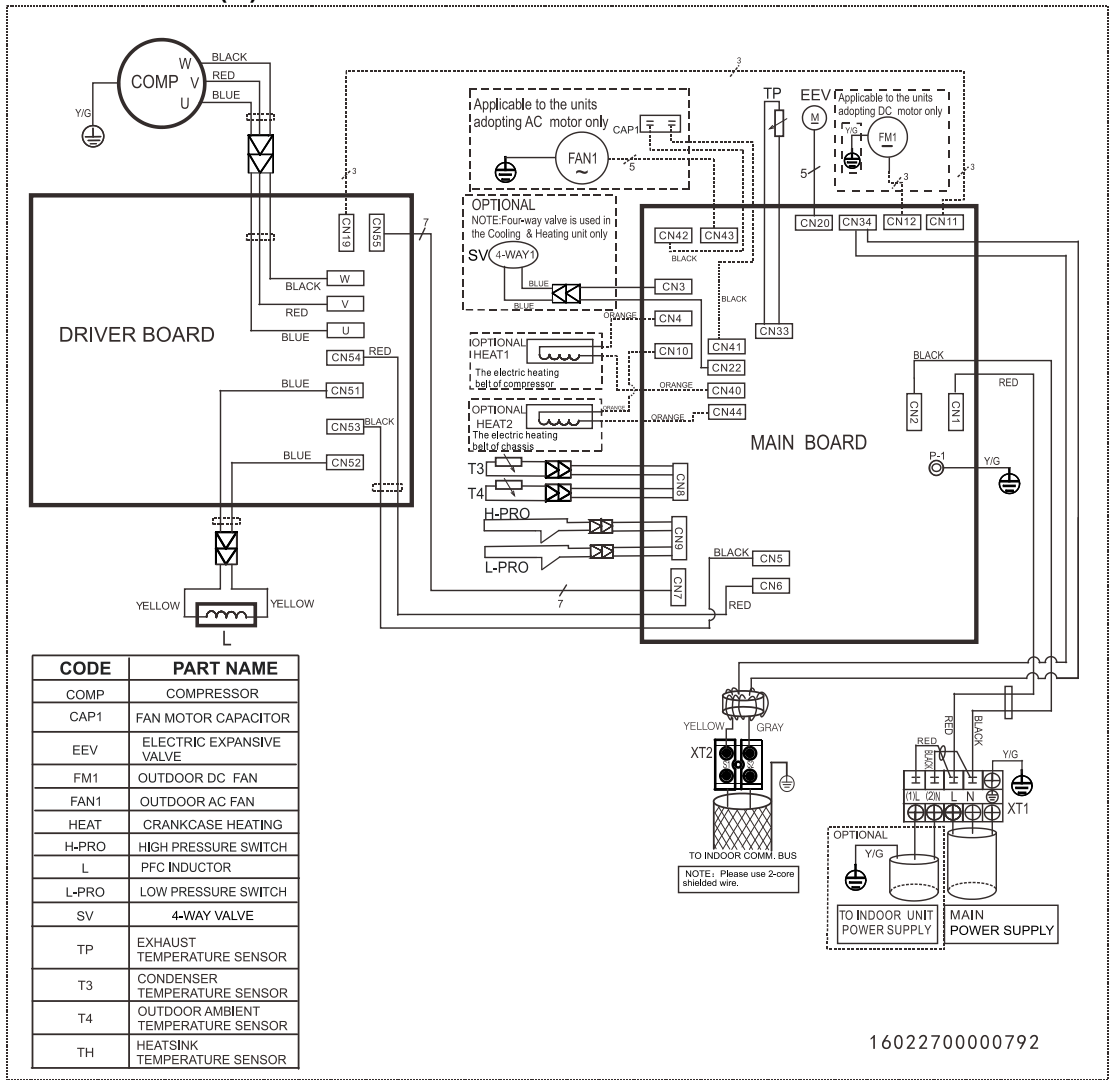

CODE	PART NAME
COMP	COMPRESSOR
CAP1	FAN MOTOR CAPACITOR
EEV	ELECTRIC EXPANSIVE VALVE
FM1	OUTDOOR DC FAN
FAN1	OUTDOOR AC FAN
HEAT	CRANKCASE HEATING
H-PRO	HIGH PRESSURE SWITCH
L	PFC INDUCTOR
L-PRO	LOW PRESSURE SWITCH
SV	4-WAY VALVE
TP	EXHAUST TEMPERATURE SENSOR
T3	CONDENSER TEMPERATURE SENSOR
T4	OUTDOOR AMBIENT TEMPERATURE SENSOR
TH	HEATSINK TEMPERATURE SENSOR

1602270000792

**TMSI48HT1<sup>3.21</sup>/(O)4SD2R1Y0T , TMSG60HT1<sup>3.42</sup>/(O)4SD2R1Y0T**

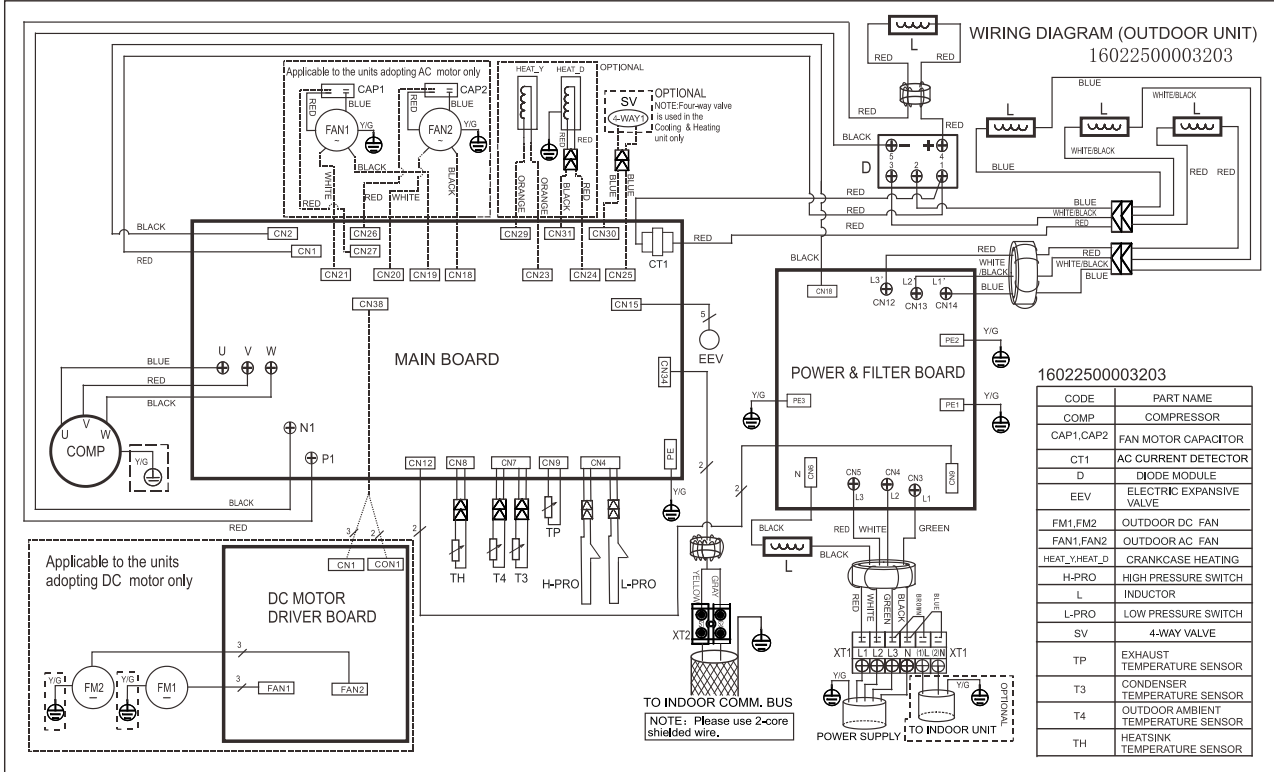

16022500003203

CODE	PART NAME
COMP	COMPRESSOR
CAP1,CAP2	FAN MOTOR CAPACITOR
CT1	AC CURRENT DETECTOR
D	DIODE MODULE
EEV	ELECTRIC EXPANSIVE VALVE
FM1,FM2	OUTDOOR DC FAN
FAN1,FAN2	OUTDOOR AC FAN
HEAT_Y,HEAT_D	CRANKCASE HEATING
H-PRO	HIGH PRESSURE SWITCH
L	INDUCTOR
L-PRO	LOW PRESSURE SWITCH
SV	4-WAY VALVE
TP	EXHAUST TEMPERATURE SENSOR
T3	CONDENSER TEMPERATURE SENSOR
T4	OUTDOOR AMBIENT TEMPERATURE SENSOR
TH	HEATSINK TEMPERATURE SENSOR

## 4. Piping Diagrams

TMSI18HT1I3.22/I(O)4SD1R1Y0S , TMSI24HT1I3.24/I(O)4SD1R1Y0S

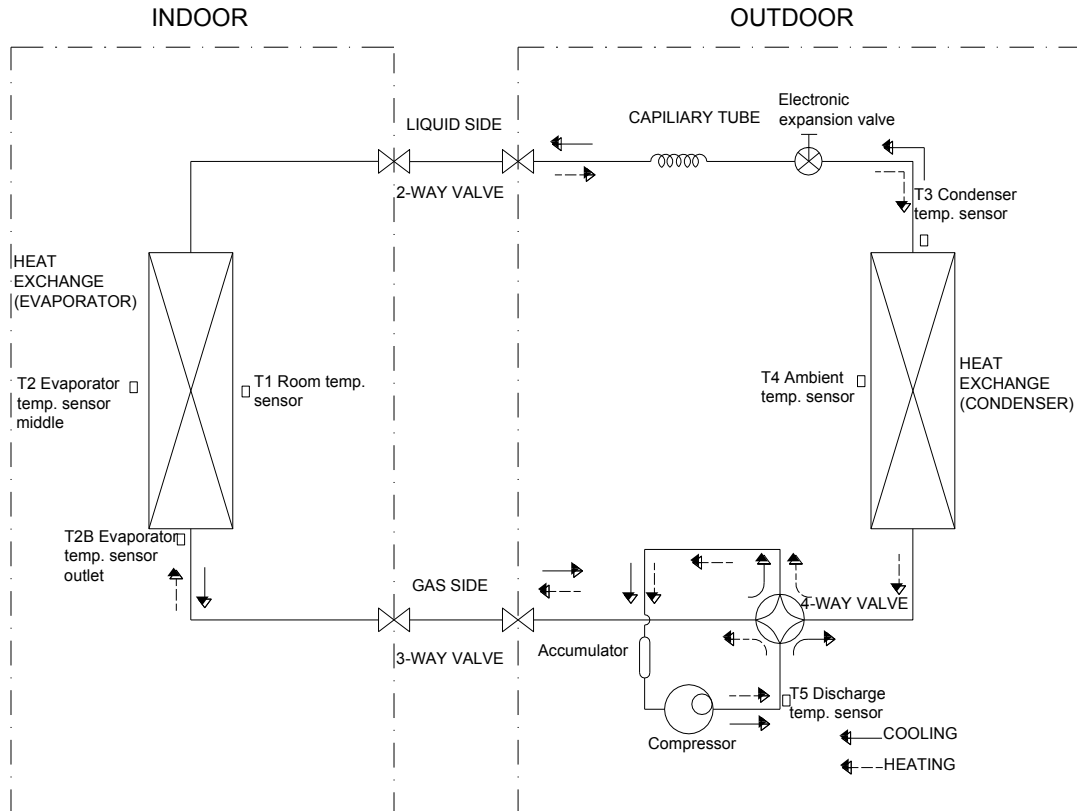

TMSI30HT1I3.24/I(O)4SD1R1Y0S , TMSI36HT1I3.25/I(O)4SD1R1Y0S, TMSI48HT1I3.21/I(O)4SD2R1Y0T

TMSG60HT1I3.42/I(O)4SD2R1Y0T

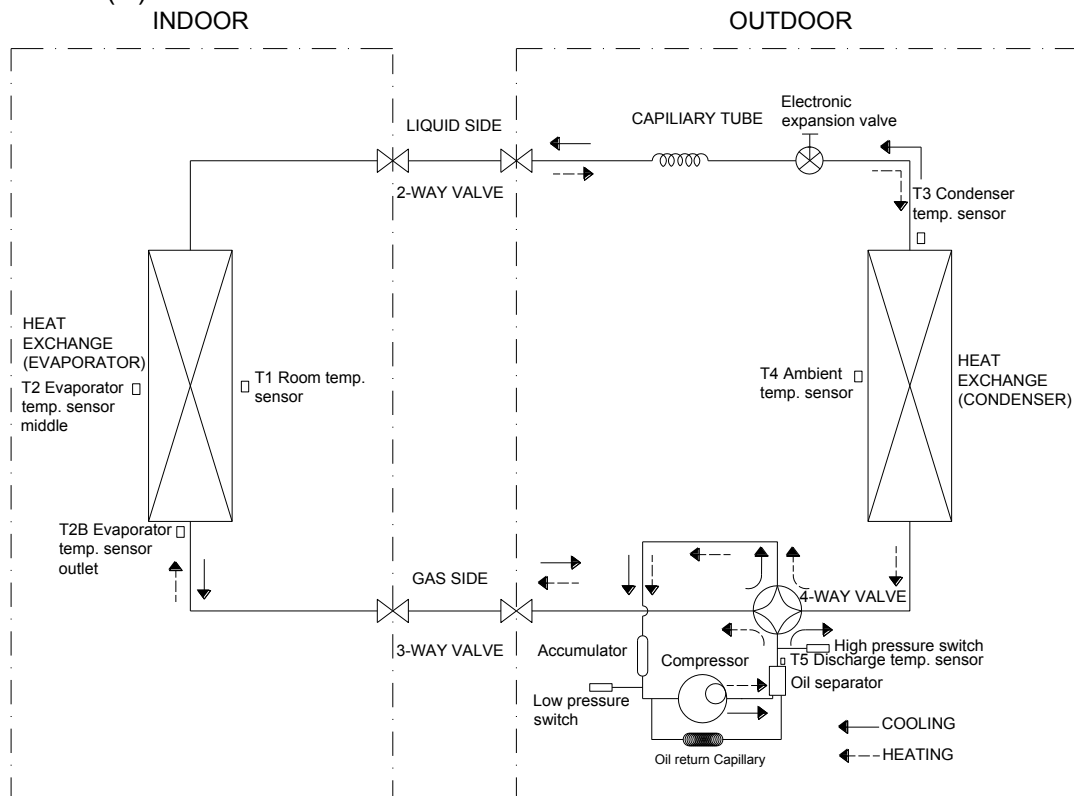

## 5. Electric Characteristics

Model	Outdoor Unit				Power Supply
	Hz	Voltage	Min.	Max.	MFA
TMSI18HT1I3.22/I(O)4SD1R1Y0S	50	220-240V	198V	254V	20
TMSI24HT1I3.24/I(O)4SD1R1Y0S	50	220-240V	198V	254V	20
TMSI30HT1I3.24/I(O)4SD1R1Y0S	50	220-240V	198V	254V	30
TMSI36HT1I3.25/I(O)4SD1R1Y0S	50	220-240V	198V	254V	30
TMSI48HT1I3.21/I(O)4SD1R1Y0S	50	380-415V	342V	440V	25
TMSG60HT1I3.42/I(O)4SD1R1Y0S	50	380-415V	342V	440V	25

Notes:

MFA: Max. Fuse Amps. (A)

## 6. Operation Limits

Mode \ Temperature	Cooling operation	Heating operation	Drying operation
Room temperature	17°C~32°C	0°C~30°C	17°C~32°C
Outdoor temperature	0°C~50°C	-15°C~24°C	0°C~50°C
	(-15°C~50°C: For the models with low temperature cooling system)		

### CAUTION:

1. If the air conditioner is used beyond the above conditions, certain safety protection features may come into operation and cause the unit to operate abnormally.
2. The room relative humidity should be less than 80%. If the air conditioner operates beyond this figure, the surface of the air conditioner may attract condensation. Please set the vertical air flow louver to its maximum angle (vertically to the floor), and set HIGH fan mode.
3. The optimum performance will be achieved during this operating temperature zone.

## 7. Sound Levels

Outdoor Unit

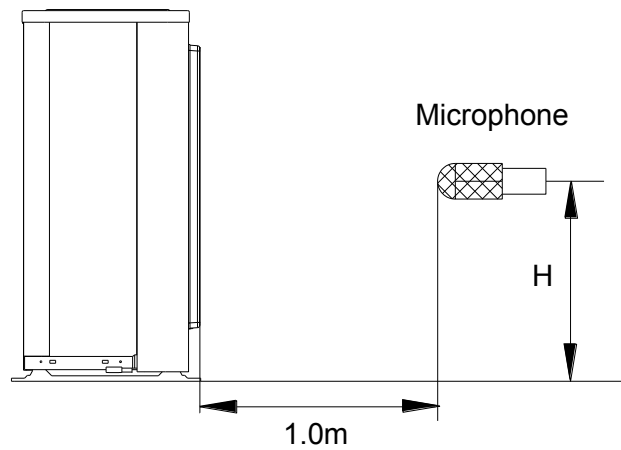

**Note:**  $H = 0.5 \times \text{height of outdoor unit}$

Model	Noise Power dB(A)	Noise level dB(A)
TMSI18HT1I3.22/I(O)4SD1R1Y0S	64	57
TMSI24HT1I3.24/I(O)4SD1R1Y0S	65	61
TMSI30HT1I3.24/I(O)4SD1R1Y0S	66	60
TMSI36HT1I3.25/I(O)4SD1R1Y0S	66	61
TMSI48HT1I3.21/I(O)4SD1R1Y0S	72	65
TMSG60HT1I3.42/I(O)4SD1R1Y0S	75	63



Air Conditioning Systems

Cooling & Heating

**TRUST AIR-CONDITIONING EQUIPMENT CO.**

Shiraz office: 8 th floor, Alvand Bldg., Dostan St.,  
Moaliabad Ave., SHIRAZ, IRAN., Post code: 71877-14446

Tel.: +98-71-36341070

Fax.: +98-71-36341094

Tehran office: No. 19- koohe nour St.- Motahhari St.-

TEHRAN, IRAN., Post code: 15876-73111

Tel.: +98-21-89389

Fax.: +98-21-88541903

Ahwaz office: No. 309- Kaveh St.- AHWAZ, IRAN., Post code: 61939-47911

Tel.: +98-61-32230647-8 E-mail: [info@trustacs.com](mailto:info@trustacs.com)

Fax.: +98-61-32230647 Web site: <http://www.trustacs.com>

برند برتر در اولین جشنواره بین المللی  
برترین نام و نشان های تجاری ایران

