

TROPICAL INVERTER VRF SYSTEM (X SERIES)



TRUST AIR CONDITIONING EQUIPMENT CO.
Prepared By: Engineering & R & D Department.

Troubleshooting

1	Outdoor Unit Electric Control Box Layout.....	2
2	Outdoor Unit Main PCB	3
3	Error Code Table	7
4	Troubleshooting	9
5	Appendix to Part 5.....	58

2016-08

1 Outdoor Unit Electric Control Box Layout

TMVV5X252H, TMVV5X280H, TMVV5X335H

Figure 5-1.1: Bottom layer of electric control box

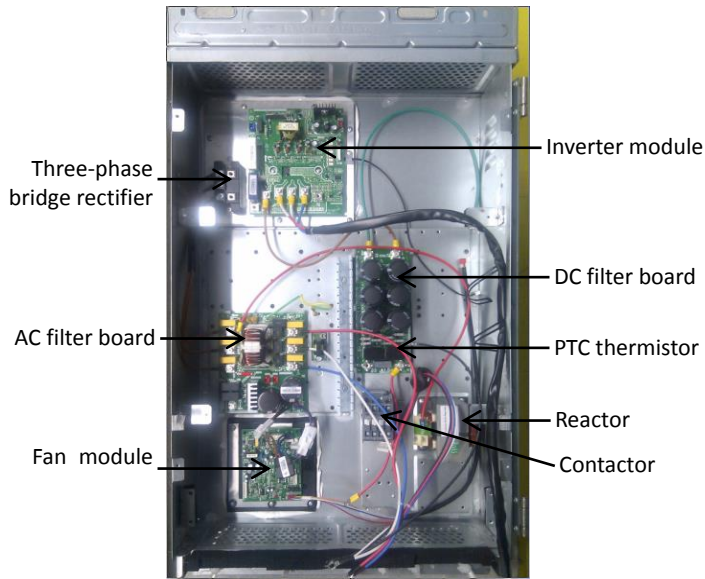
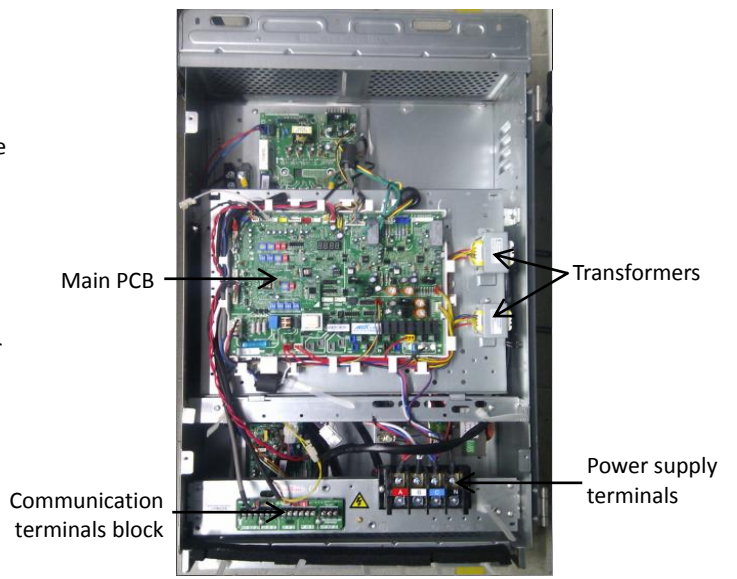

Figure 5-1.2: Top layer of electric control box



TMVV5X400H, TMVV5X450H, TMVV5X500H, TMVV5X560H, TMVV5X615H

Figure 5-1.3: Bottom layer of electric control box

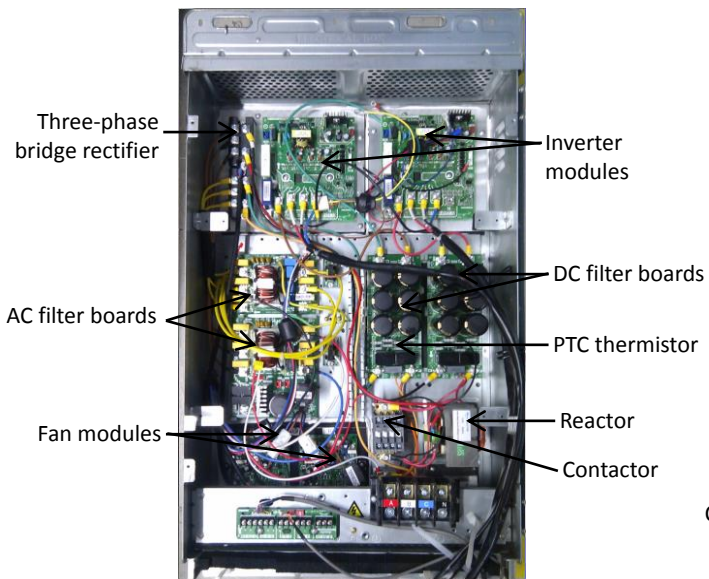
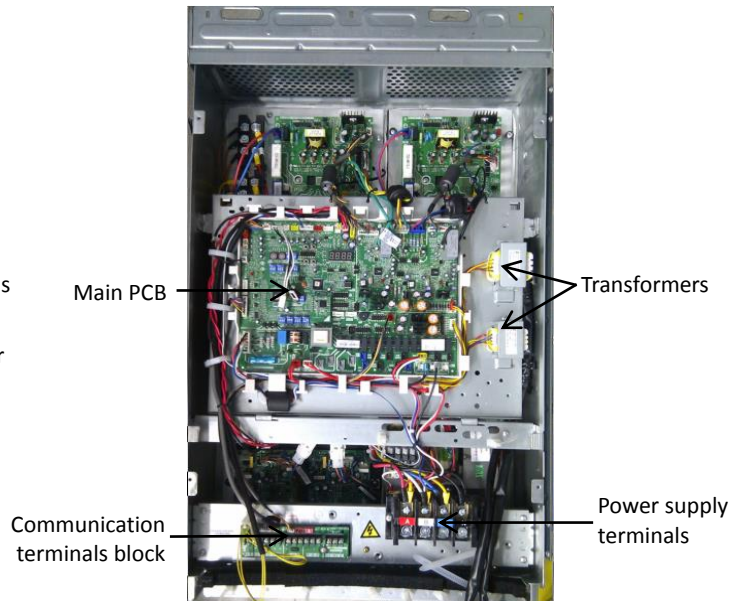

Figure 5-1.4: Top layer of electric control box



2 Outdoor Unit Main PCB

2.1 Types

There are four main PCB types for X outdoor units. 8/10/12HP units share a main PCB type, 14/16HP share a main PCB type, 18HP has a unique main PCB type, and 20/22HP share a main PCB type. The type label is affixed to the main PCB. When changing a main PCB, be sure to use the right type of main PCB. Refer to Table 2-1.1.

Table2-1.1: Main PCB type labels

Capacity	8/10/12HP	14/16HP	18HP	20/22HP ¹
Label				

- Notes:
- The 20/22HP main PCB can also be used on 8/10/12HP units. The only difference is that the 20/22HP main PCB has two inverter modules whilst the 8/10/12HP main PCB has one inverter module. If a 20/22HP main PCB is used on an 8/10/12HP unit, the unit will run normally but LED6 will flash and LED7 will be continuously on.

2.2 Ports

Figure 2-2.1: Outdoor unit main PCB ports¹

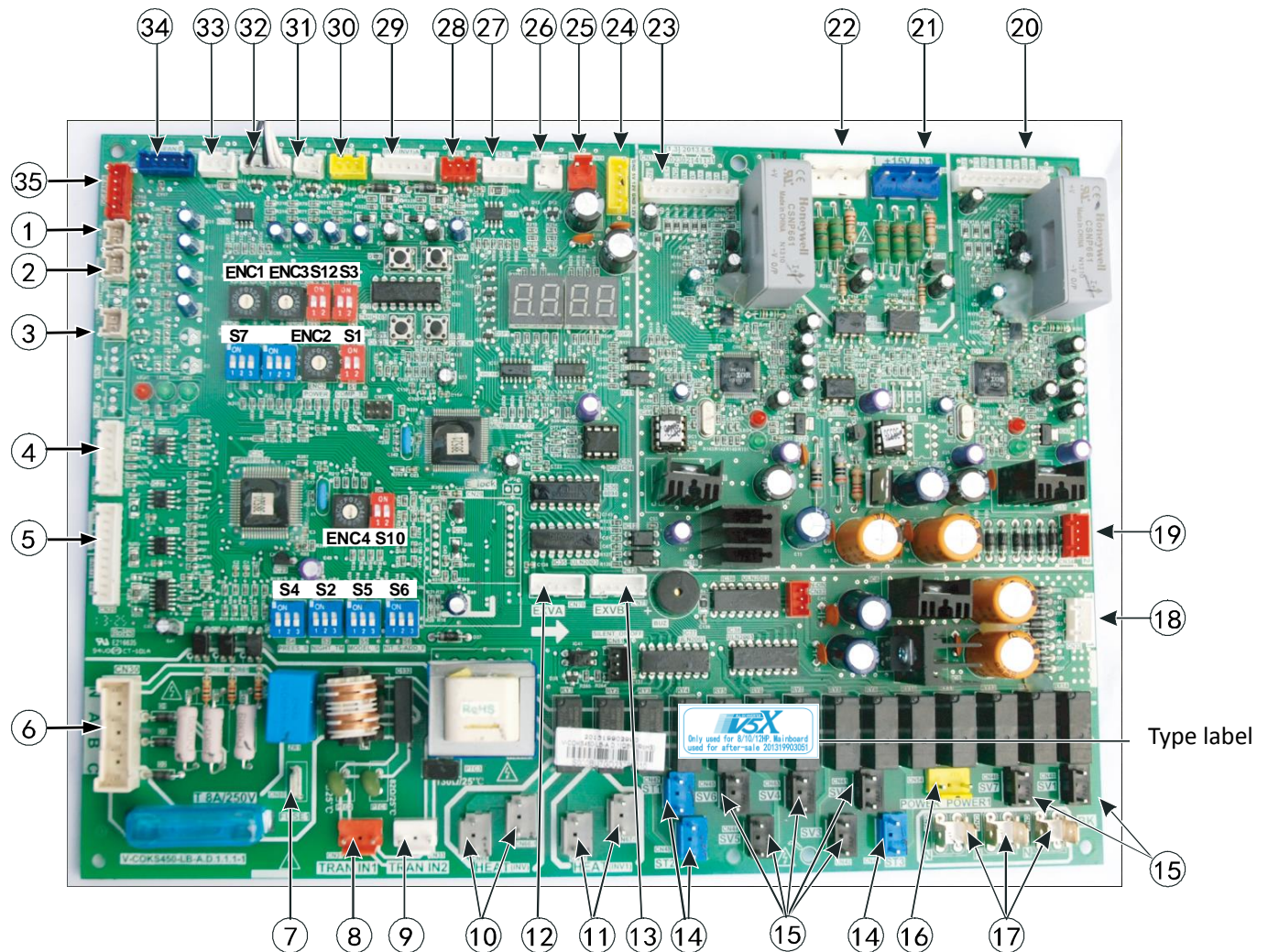

- Notes:
- Label descriptions are given in Table2-2.2.

Table 2-2.2: Main PCB ports

Label in Figure 5-2.1	Port code	Content	Port voltage
1	CN10	Compressor top temperature sensor (single compressor units) or compressor A compressor top temperature sensor (dual compressor units) connection	0-5V DC (varying)
2	CN11	Discharge pipe temperature sensor (single compressor units) or compressor B compressor top temperature sensor (dual compressor units) connection	0-5V DC (varying)
3	CN4	Inverter module temperature sensor connection	0-5V DC (varying)
4	CN26	Reserved	
5	CN25	Communication port	2.5-2.7V DC
6	CN30	Power input	380V
7	CN80	Reserved	
8	CN31	No.1 transformer power input	220V
9	CN33	No.2 transformer power input	220V
10	CN66	Power supply to compressor A crankcase heater	220V
11	CN67	Power supply to compressor B crankcase heater	220V
12	CN70	EVXA drive port	First pin on the left: 12V DC; other four pins: varying
13	CN71	EVXB drive port	
14	CN47- CN49	Four-way valve drive ports	220V
15	CN41- CN45	Solenoid valve drive ports	220V
16	CN54	Power output	220V
17	CN57- CN59	Neutral terminals	0
18	CN32	No.1 transformer power output	Voltage between upper two pins: 13.5V AC; voltage between lower two pins: 9V AC
19	CN34	No.2 transformer power output	Voltage between upper two pins: 14.5V AC; voltage between lower two pins: 14.5V AC
20	CN39	Inverter module B control port	Third pin on the left: 3.3V DC
21	CN38	Inverter module B voltage monitor port	540V DC, +15V DC, N
22	CN36	Inverter module A voltage monitor port	540V DC, +15V DC, N
23	CN37	Inverter module A control port	Third pin on the left: 3.3V DC
24	CN35	5V DC, 12V DC power input	GND, +5V, +12V, GND, 12V
25	CN19	Low pressure switch connection	0 or 5V
26	CN18	High pressure switch and discharge temperature switch(es) connections	0 or 5V
27	CN28	Reserved	
28	CN16	Reserved	
29	CN15	Inverter compressor A and B current sensor connections	0-7.8V AC (varying)
30	CN17	High pressure sensor connection	0-5V DC (varying)
31	CN2	Reserved	
32	CN1	Outdoor ambient temperature sensor and outdoor heat exchanger temperature sensor connections	0-5V DC (varying)
33	CN20	Outdoor units communication port	2.5-2.7V DC
34	CN65	Fan B control port	First pin on the left: 12V DC; other four pins: varying
35	CN64	Fan A control port	

2.3 Components

2.3.1 Layout

Figure 2-3.1: Outdoor unit main PCB components

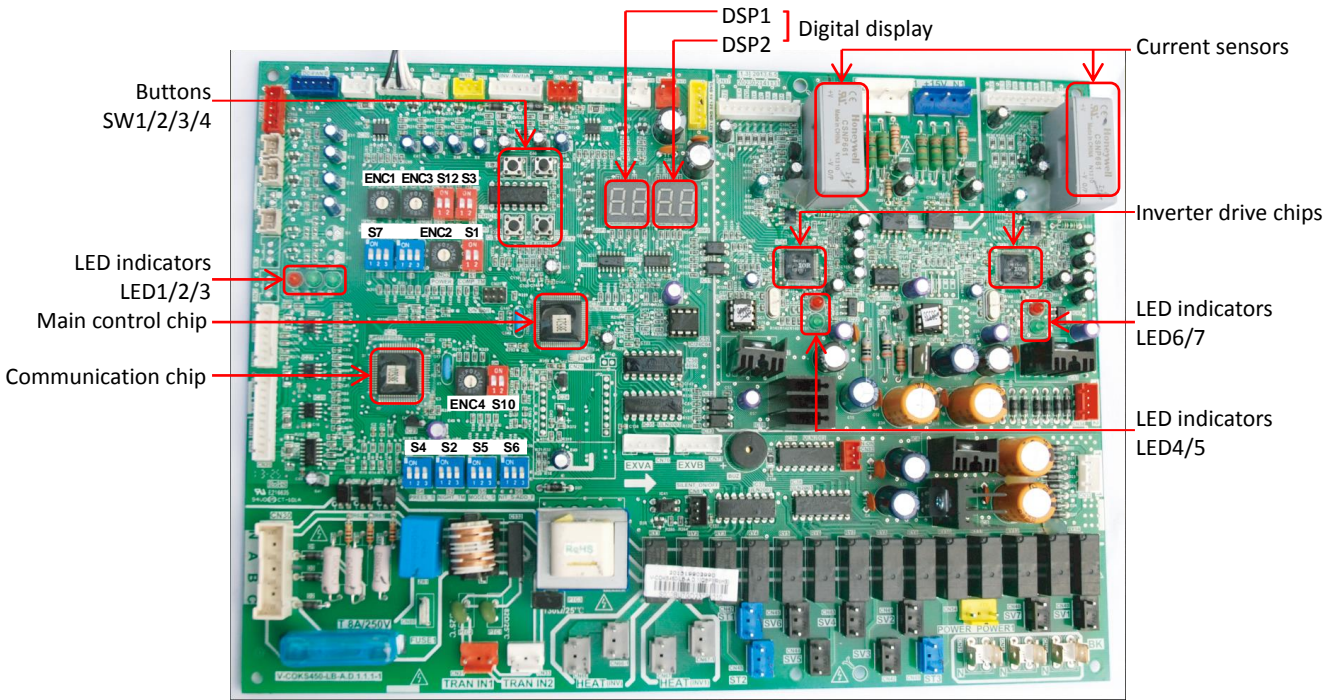

2.3.2 Function of buttons SW1 to SW4

Table 2-3.2: Function of buttons SW1 to SW4

Button	Function
SW1	Force cooling
SW2	System check
SW3	Check for specific errors
SW4	Reserved

2.3.3 SW2 system check button

Before pressing SW2, allow the system to operate steadily for more than an hour. On pressing SW2, the parameters listed in Table 2-3.3 will be displayed in sequence.

Table 2-3.3: SW2 system check

DSP1 content	Parameters displayed on DSP2	Remarks
- 0	Outdoor unit address	Master unit: 0; slave units: 1, 2, 3
- 1	Outdoor unit capacity	Refer to Note 1
- 2	Number of outdoor units	Displayed on master unit PCB only
- 3	Number of indoor units as set on PCB	Displayed on master unit PCB only
- 4	Outdoor unit output metric (total of all units)	Displayed on master unit PCB only
- 5	Indoor unit demand metric (total of all units)	
- 6	Outdoor unit output metric (master unit)	
- 7	Operating mode	Refer to Note 2
- 8	Outdoor unit output metric (this unit)	
- 9	Fan A speed index	Refer to Note 3

Table continued on next page ...

Table 2-3.3: SW2 system check (continued)

DSP1 content	Parameters displayed on DSP2	Remarks
10	Fan B speed index	Refer to Note 3
11	Indoor heat exchanger pipe temperature (°C)	Actual value = value displayed
12	Outdoor heat exchanger pipe temperature (°C)	Actual value = value displayed
13	Outdoor ambient temperature (°C)	Actual value = value displayed
14	Inverter compressor A discharge temperature (°C)	Actual value = value displayed
15	Inverter compressor B discharge temperature (°C)	Actual value = value displayed
16	Main inverter module temperature (°C)	Actual value = value displayed
17	Saturation temperature (°C) corresponding to the discharge pressure	Actual value = value displayed + 30
18	Inverter compressor A current (A)	Actual value = value displayed
19	Inverter compressor B current (A)	Actual value = value displayed
20	EXVA position	Steps = value displayed × 8
21	EXVB position	Steps = value displayed × 8
22	Compressor discharge pressure (MPa)	Actual value = value displayed × 0.1
23	Reserved	
24	Number of indoor units currently in communication with master unit	Actual value = value displayed
25	Number of indoor units currently operating	Actual value = value displayed
26	Priority mode	Refer to Note 4
27	Silent mode	Refer to Note 5
28	Static pressure mode	Refer to Note 6
29	DC voltage A	Actual value = value displayed × 10
30	DC voltage B	Actual value = value displayed × 10
31	Reserved	
32	Most recent error or protection code	000 is displayed if no error or protection events have occurred since start-up
33	Error clearance metric	Actual value = value displayed
34	----	End

Notes:

1. Outdoor unit capacity setting:
 - 0: 8HP; 1: 10HP; 2: 12HP; 3: 14HP; 4: 16HP; 5: 18HP; 6: 20HP; 7: 22HP.
2. Operating mode:
 - 0: off; 2: cooling; 3: heating; 4: forced cooling.
3. The fan speed index is related to the fan speed in rpm as described in Table 3-5.3 in Part 3, 5.6 "Outdoor Fan Control".
4. Priority mode:
 - 0: heating priority; 1: cooling priority; 2: VIP priority or voting priority; 3: heating only; 4: cooling only.
5. Silent mode:
 - 0: night silent mode; 1: silent mode; 2: super silent mode; 3: no silent mode.
6. Static pressure mode:
 - 0: standard static pressure; 1: low static pressure; 2: medium static pressure; 3: high static pressure.

2.3.4 Digital display output

Table 2-3.4: Digital display output in different operating states

Outdoor unit state		Parameters displayed on DSP1	Parameters displayed on DSP2
On standby		Unit's address	The number of indoor units in communication with the outdoor units
Normal operation	For single compressor units	--	Running speed of the compressor in rotations per second
	For dual compressor units	Running speed of compressor B in rotations per second	Running speed of compressor A in rotations per second
Error or protection		-- or placeholder	Error or protection code
System check		Refer to Table 5-2.4	Refer to Table 5-2.4

2.3.5 LED indicators LED1 to LED7

Table 2-3.5: LED indicators LED1 to LED7

Indicator	LED indicator function and status	
LED1	Power supply indicator. Continuously on if the power supply is normal.	
LED2	Running indicator. Continuously on if the system is operating normally and flashing if the system has a problem.	
LED3	Communication chip malfunction indicator. Flashing if a three-phase sequence protection error or communication error has occurred.	
LED4/6	Inverter module operating indicator. Continuously on if the compressor is running normally and flashing if an inverter module error has occurred ¹ .	
LED5/7	Inverter module error indicator. Continuously on if an inverter module error has occurred ¹ .	

Notes:

1. If an inverter module error occurs, refer to Part 5, 4.11 "xH4 Troubleshooting". The error code is displayed on the digital display.

3 Error Code Table

Table 3.1: Error code table

Error code ¹	Content	Remarks
E0	Communication error between outdoor units	Only displayed on the slave unit with the error
E1	Phase sequence error	Displayed on the unit with the error
E2	Communication error between indoor and master unit	Only displayed on the master unit
E4	Outdoor ambient temperature sensor error	Displayed on the unit with the error
E5	Abnormal power supply voltage	Displayed on the unit with the error
E7	Compressor top or discharge pipe temperature sensor error	Displayed on the unit with the error
E8	Outdoor unit address error	Displayed on the unit with the error
xE9	EEPROM mismatch	Displayed on the unit with the error
xH0	Communication error between main control chip and inverter driver chip	Displayed on the unit with the error
H1	Communication error between main control chip and communication chip	Displayed on the unit with the error
H2	Number of slave units detected by master unit has decreased	Only displayed on the master unit
H3	Number of slave units detected by master unit has increased	Only displayed on the master unit
xH4	Inverter module protection	Displayed on the unit with the error

Notes:

1. 'x' is a placeholder for the compressor system (compressor and related electrical components), with 1 representing compressor system A and 2 representing compressor system B. 'y' is a placeholder for the address (1, 2 or 3) of the slave unit with the error.

Table continued on next page ...

Table 3.1: Error code table (continued)

Error code ¹	Content	Remarks
H7	Number of indoor units detected by master unit not same as number set on main PCB	Only displayed on the master unit
H8	Discharge pipe low pressure protection.	Displayed on the unit with the error
yHd	Slave unit malfunction	Only displayed on the master unit
P0	Compressor temperature protection	Displayed on the unit with the error
P1	Discharge pipe high pressure protection	Displayed on the unit with the error
P2, H5	Suction pipe low pressure protection	Displayed on the unit with the error
xP3	Compressor current protection	Displayed on the unit with the error
P4, H6	Discharge temperature protection	Displayed on the unit with the error
P5	Outdoor heat exchanger temperature protection	Displayed on the unit with the error
P9, H9	Fan module protection	Displayed on the unit with the error
PL, C7	Inverter module temperature protection	Displayed on the unit with the error
PP, F0	Compressor discharge insufficient superheat protection	Displayed on the unit with the error
dF	Defrosting operation	
d0	Oil return operation	
xL0	Inverter module protection	
xL1	DC bus low voltage protection	
xL2	DC bus high voltage protection	
xL4	MCE error	
xL5	Zero speed protection	
xL7	Phase sequence error	
xL8	Compressor frequency variation greater than 15Hz within one second protection	
xL9	Actual compressor frequency differs from target frequency by more than 15Hz protection	
r1	Refrigerant quantity slightly insufficient protection	
r2	Refrigerant quantity significantly insufficient protection	
r3	Refrigerant quantity critically insufficient protection	
R1	Refrigerant quantity slightly excessive protection	
R2	Refrigerant quantity critically excessive protection	

Notes:

- 'x' is a placeholder for the compressor system (compressor and related electrical components), with 1 representing compressor system A and 2 representing compressor system B. 'y' is a placeholder for the address (1, 2 or 3) of the slave unit with the error.

4 Troubleshooting

4.1 Warning

Warning



- All electrical work must be carried out by competent and suitably qualified, certified and accredited professionals and in accordance with all applicable legislation (all national, local and other laws, standards, codes, rules, regulations and other legislation that apply in a given situation).
- Power-off the outdoor units before connecting or disconnecting any connections or wiring, otherwise electric shock (which can cause physical injury or death) may occur or damage to components may occur.

4.2 E0 Troubleshooting

4.2.1 Digital display output

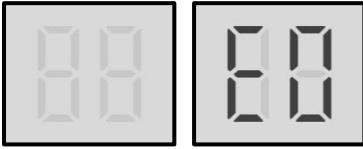

4.2.2 Description

- Communication error between outdoor units.
- All units stop running.
- Error code is only displayed on the slave unit with the error.

4.2.3 Possible causes

- Incorrect outdoor unit address setting.
- Communication wires between outdoor units not connected properly.
- Loosened wiring within electric control box.
- Damaged main PCB or electric control box communication terminals block.

4.2.4 Procedure

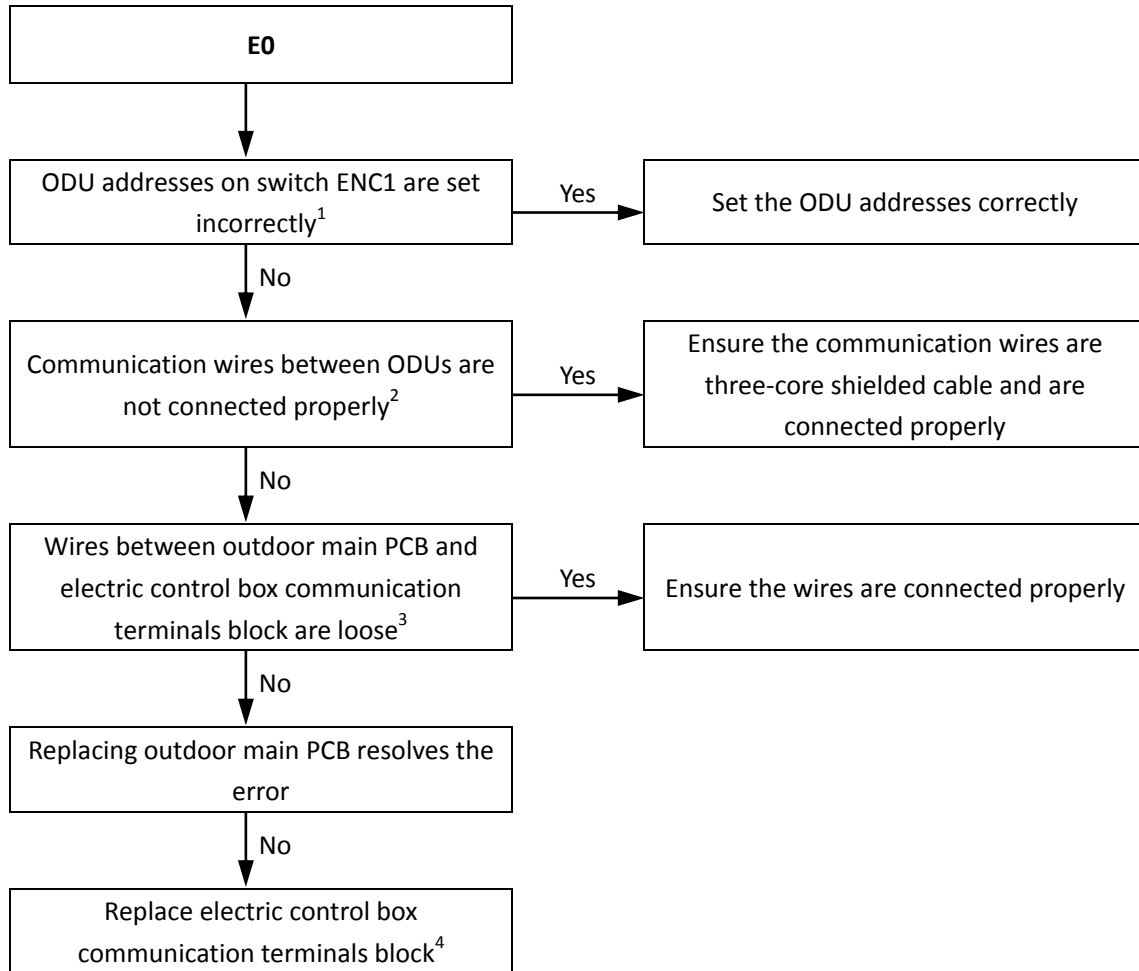

Notes:

1. The master unit address should be set as 0, slave units addresses should be set from 1 to 3, and the addresses should not be repeated within one system. Refer to Part 4, 1.1 "PCB Switches and Switch Settings".
2. All the wires for H1, H2, E connections should be three-core shielded cable, the wiring should be connected according to polarity (H1 to H1, etc), the wiring should not be open or short circuited. Refer to the V5 X Engineering Data Book, Part 2, 5 "Wiring Diagrams" and Part 3, 9.3 "Communication Wiring".
3. Refer to Figures 5-1.2 and 5-1.4 in Part 5, 1 "Outdoor Unit Electric Control Box Layout" and to the V5 X Engineering Data Book, Part 2, 5 "Wiring Diagrams".
4. Refer to Figures 5-1.2 and 5-1.4 in Part 5, 1 "Outdoor Unit Electric Control Box Layout".

4.3 E1 Troubleshooting

4.3.1 Digital display output

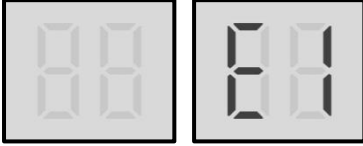

4.3.2 Description

- Phase sequence error.
- All units stop running.
- Error code is only displayed on the unit with the error.

4.3.3 Possible causes

- Power supply phases not connected in correct sequence.
- Power supply terminals loose.
- Power supply abnormal.
- Main PCB damaged.

4.3.4 Procedure

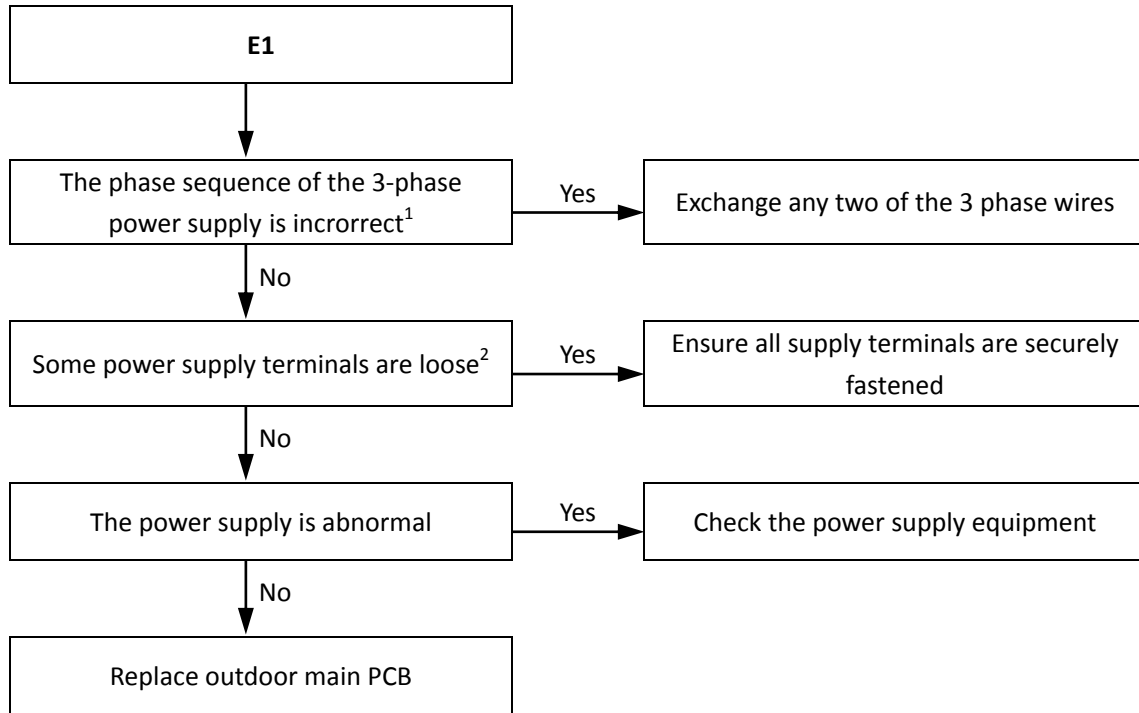

Notes:

1. The A, B, C terminals of 3-phase power supply should match compressor phase sequence requirements. If the phase sequence is inverted, the compressor will operate inversely. If the wiring connection of each outdoor unit is in A, B, C phase sequence, and multiple units are connected, the current difference between C phase and A, B phases will be very large as the power supply load of each outdoor unit will be on C phase. This can easily lead to tripped circuits and terminal wiring burnout. Therefore if multiple units are to be used, the phase sequence should be staggered, so that the current is distributed among the three phases equally. Refer to Figures 5-1.2 and 5-1.4 in Part 5, 1 "Outdoor Unit Electric Control Box Layout".
2. Loose power supply terminals can cause the compressors to operate abnormally and compressor current to be very large. Refer to Figures 5-1.2 and 5-1.4 in Part 5, 1 "Outdoor Unit Electric Control Box Layout".

4.4 E2 Troubleshooting

4.4.1 Digital display output

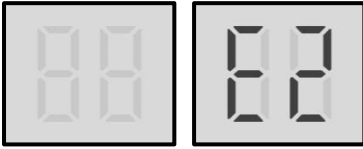

4.4.2 Description

- Communication error between indoor and master unit.
- All units stop running.
- Error code is only displayed on the master unit.

4.4.3 Possible causes

- Communication wires between indoor and outdoor units not connected properly.
- Indoor unit power supply abnormal.
- Loosened wiring within electric control box.
- Interference from high voltage wires or other sources of electromagnetic radiation.
- Communication wire too long.
- Damaged main PCB or electric control box communication terminals block.

4.4.4 Procedure

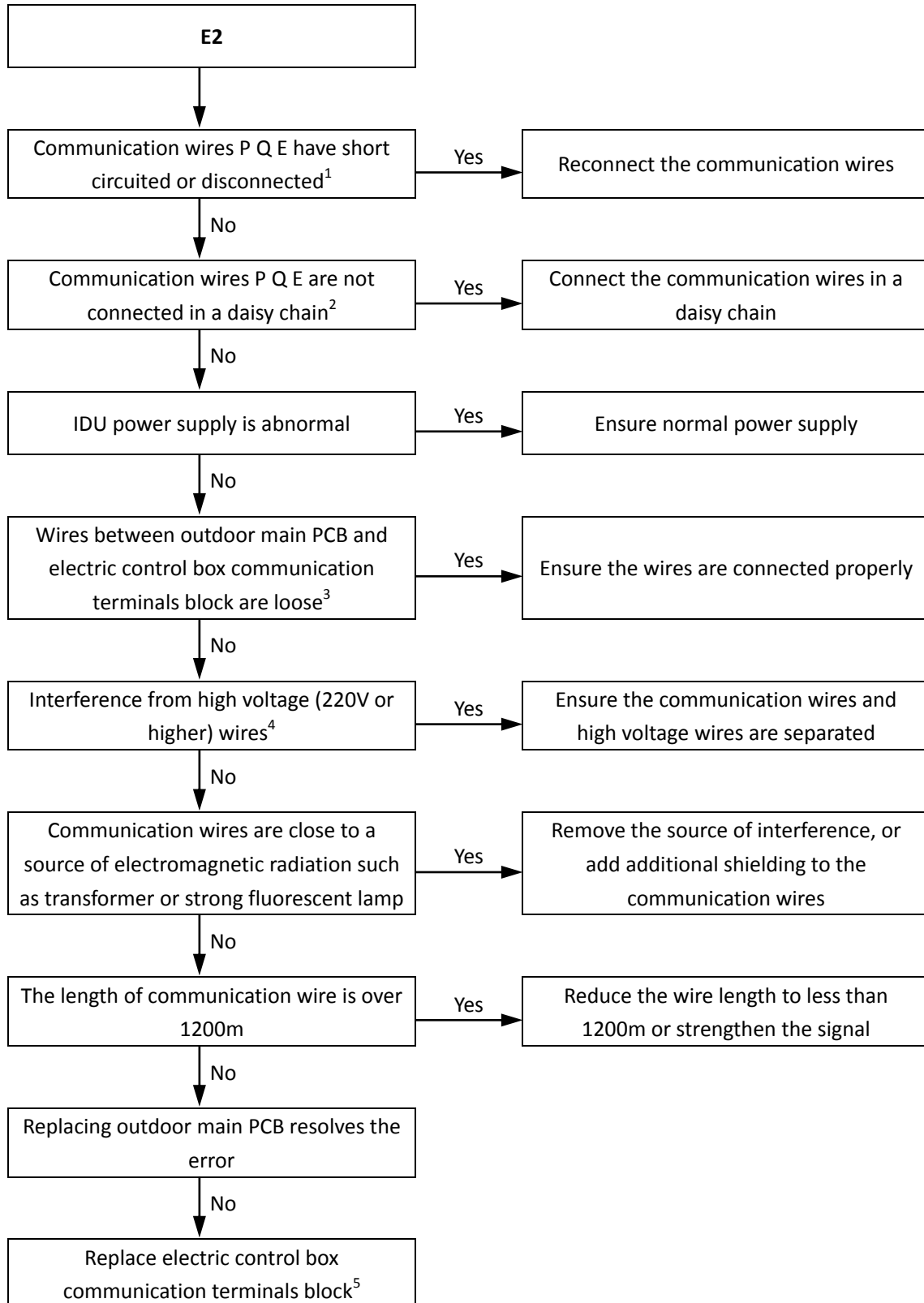

Notes:

1. Measure the resistance among P, Q and E. The normal resistance between P and Q is 120Ω, between P and E is infinite, between Q and E is infinite. Refer to Figures 5-1.2 and 5-1.4 in Part 5, 1 "Outdoor Unit Electric Control Box Layout" and to the V5 X Engineering Data Book, Part 3, 9.3 "Communication Wiring".
2. Refer to the V5 X Engineering Data Book, Part 3, 9.3 "Communication Wiring".
3. Refer to Figures 5-1.2 and 5-1.4 in Part 5, 1 "Outdoor Unit Electric Control Box Layout" and to the V5 X Engineering Data Book, Part 2, 5 "Wiring Diagrams".
4. Refer to the V5 X Engineering Data Book, Part 3, 9.1 "General" for required separation distances between communication wiring and power wiring.
5. Refer to Figures 5-1.2 and 5-1.4 in Part 5, 1 "Outdoor Unit Electric Control Box Layout".

4.5 E4, E7 Troubleshooting

4.5.1 Digital display output

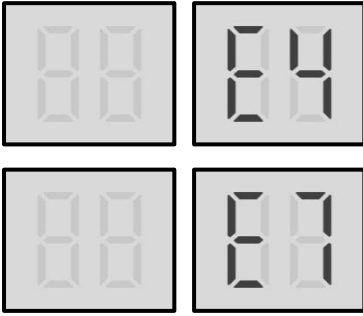

4.5.2 Description

- E4 indicates an outdoor ambient temperature sensor error.
- E7 indicates a compressor top temperature sensor or discharge pipe temperature sensor error.
- All units stop running.
- Error code is only displayed on the unit with the error.

4.5.3 Possible causes

- Temperature sensor not connected properly or has malfunctioned.
- Damaged main PCB.

4.5.4 Procedure

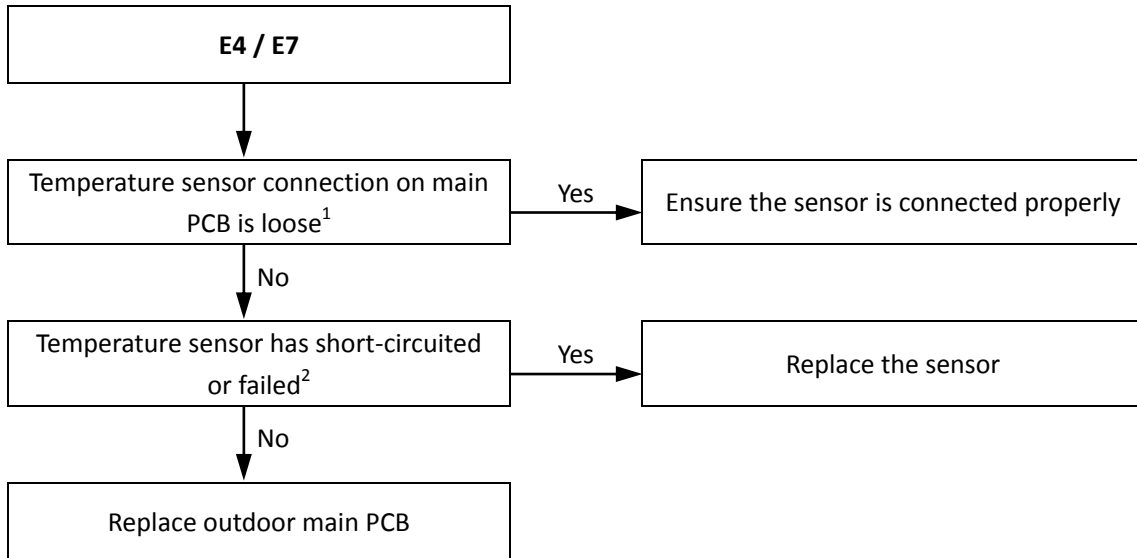

Notes:

1. Outdoor ambient temperature sensor connection is port CN1 on the main PCB (labeled 32 in Figure 5-2.1 in Part 5, 2.2 "Ports"). Compressor top temperature sensor and discharge pipe temperature sensor connections are ports CN10 and CN11 on the main PCB (labeled 1 and 2, respectively, in Figure 5-2.1 in Part 5, 2.2 "Ports").
2. Measure sensor resistance. If the resistance is too low, the sensor has short-circuited. If the resistance is not consistent with the sensor's resistance characteristics table, the sensor has failed. Refer to Part 2, 1 "Layout of Functional Components" and to Table 5-5.1 or 5-5.2 in Part 5, 5.1 "Temperature Sensor Resistance Characteristics".

4.6 E5 Troubleshooting

4.6.1 Digital display output

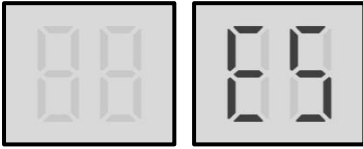

4.6.2 Description

- Abnormal power supply voltage.
- All units stop running.
- Error code is only displayed on the unit with the error.

4.6.3 Possible causes

- Outdoor unit power supply voltage not within $\pm 10\%$ of rated voltage or a phase is missing.
- Loosened wiring within electric control box.
- High voltage circuit error.
- Main PCB damaged.

4.6.4 Procedure

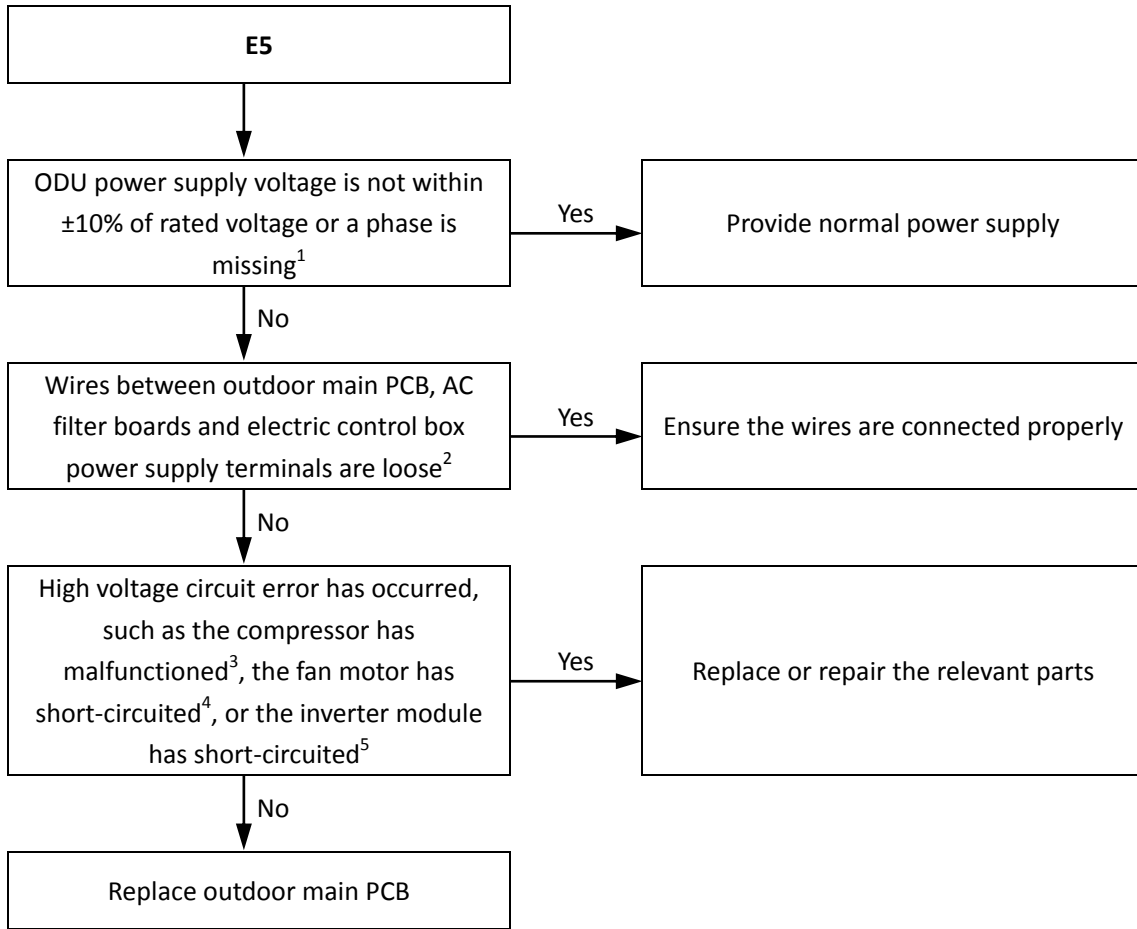

Notes:

1. The normal voltage between A and N, B and N, and C and N is 198-242V.
2. Refer to Figures 5-1.1 to 5-1.4 in Part 5, 1 "Outdoor Unit Electric Control Box Layout" and to the V5 X Engineering Data Book, Part 2, 5 "Wiring Diagrams".
3. The normal resistances of the inverter compressor are 0.7-1.5Ω among U V W and infinite between each of U V W and ground. If any of the resistances differ from these specifications, the compressor has malfunctioned. Refer to Figures 5-4.6 and 5-4.7 in Part 5, 4.11.6 "xLO troubleshooting".
4. The normal resistances of the fan motor coil among U V W are less than 10Ω. If a measured resistance is 0Ω, the fan motor has short-circuited. Refer to Part 2, 1 "Layout of Functional Components".
5. Set a multi-meter to buzzer mode and test any two terminals of P N and U V W of the inverter module. If the buzzer sounds, the inverter module has short-circuited. Refer to Figures 5-1.1 and 5-1.3 in Part 5, 1 "Outdoor Unit Electric Control Box Layout" and to Figure 5-4.1.

Figure 5-4.1: Inverter module terminals



4.7 E8 Troubleshooting

4.7.1 Digital display output

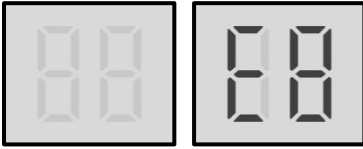

4.7.2 Description

- Outdoor unit address error.
- All units stop running.
- Error code is only displayed on the unit with the error.

4.7.3 Possible causes

- Invalid outdoor unit address.
- Main PCB damaged.

4.7.4 Procedure

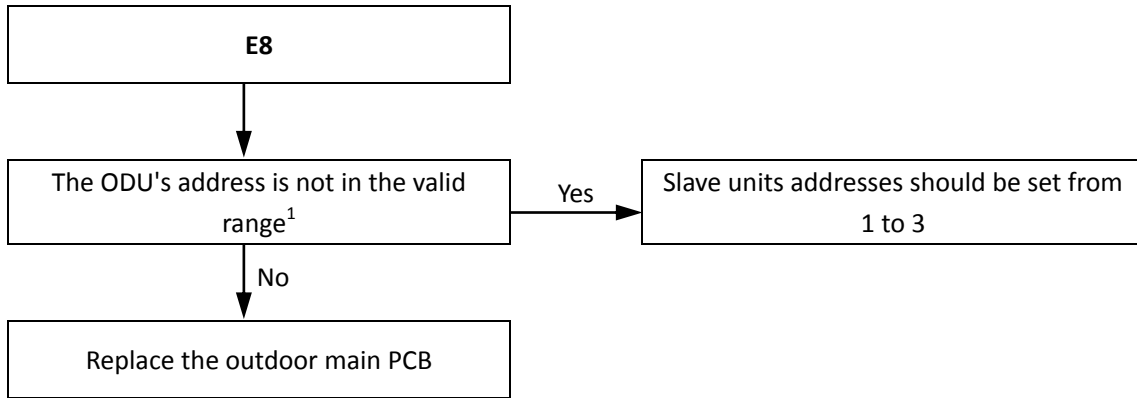

Notes:

1. The master unit address should be set as 0, slave units addresses should be set from 1 to 3, and the addresses should not be repeated within one system. Refer to Part 4, 1.1 "PCB Switches and Switch Settings".

4.8 xE9 Troubleshooting

4.8.1 Digital display output

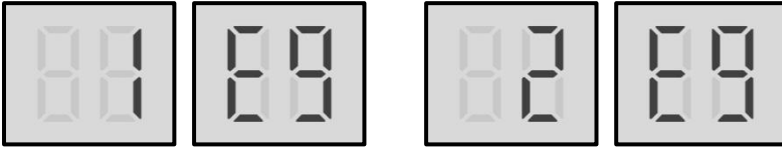

In the error code, 'x' is a placeholder for the compressor system (compressor and related electrical components), with 1 representing compressor system A and 2 representing compressor system B.

4.8.2 Description

- 1E9 indicates a compressor A EEPROM mismatch.
- 2E9 indicates a compressor B EEPROM mismatch.
- All units stop running.
- Error code is only displayed on the unit with the error.

4.8.3 Possible causes

- Outdoor unit was powered on immediately after being powered off.
- Main PCB damaged.

4.8.4 Procedure

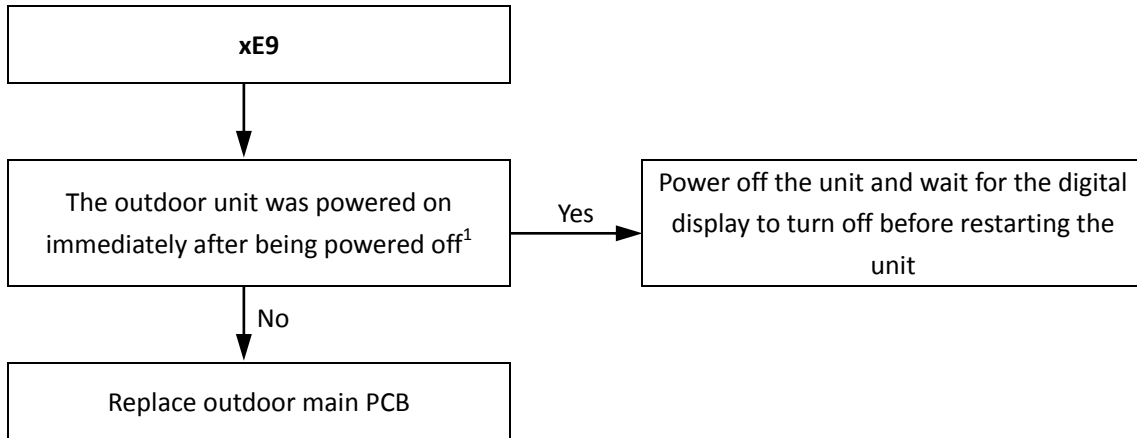

Notes:

1. When performing a manual restart of an outdoor unit, once the unit has been powered off it should not be powered on again until the digital display has turned off.

4.9 xH0, H1 Troubleshooting

4.9.1 Digital display output

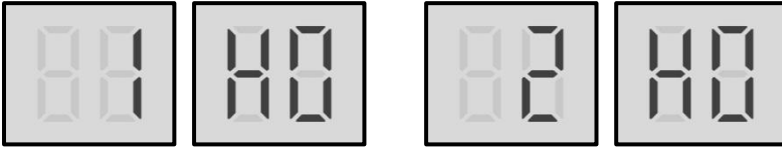

In the error code, 'x' is a placeholder for the compressor system (compressor and related electrical components), with 1 representing compressor system A and 2 representing compressor system B.

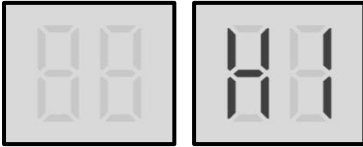

4.9.2 Description

- 1H0 indicates a communication error between the main control chip and the compressor A inverter driver chip.
- 2H0 indicates a communication error between the main control chip and the compressor B inverter driver chip.
- H1 indicates a communication error between the main control chip and the communication chip.
- All units stop running.
- Error code is only displayed on the unit with the error.

4.9.3 Possible causes

- Power supply abnormal.
- Transformer malfunction.
- Interference from a source of electromagnetic radiation.
- Main PCB damaged.

4.9.4 Procedure

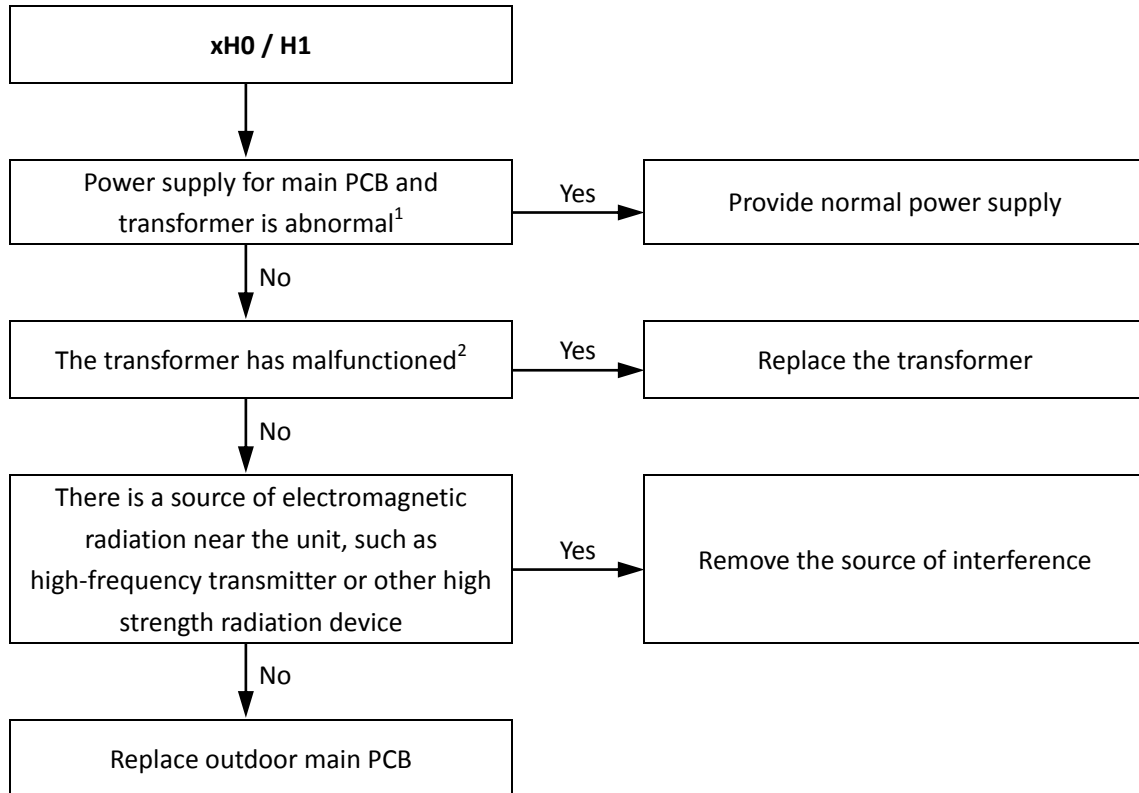

Notes:

1. Measure the voltages of ports CN31, CN33 and CN35 on the main PCB (labeled 8, 9 and 24, respectively, in Figure 5-2.1 in Part 5, 2.2 "Ports"). The normal voltage between CN31 and CN33 terminals is 220V, between GND and the 5V pins of CN35 is 5V, between GND and 12V pins of CN35 is 12V. If one or more of the voltages are not normal, the power supply for main PCB and transformer is abnormal.
2. Measure the voltages of ports CN32 and CN34 on the main PCB (labeled 18 and 19, respectively, in Figure 5-2.1 in Part 5, 2.2 "Ports"). The normal voltage across the upper two pins of CN32 is 13.5V (AC), across the lower two pins is 9V (AC). The normal voltage across the upper two pins of CN34 is 14.5V (AC), across the lower two pins is 14.5V (AC). If one or more of the voltages are not normal, the transformer has malfunctioned. Refer to Figure 5-4.2.

Figure 5-4.2: Transformer power output terminals

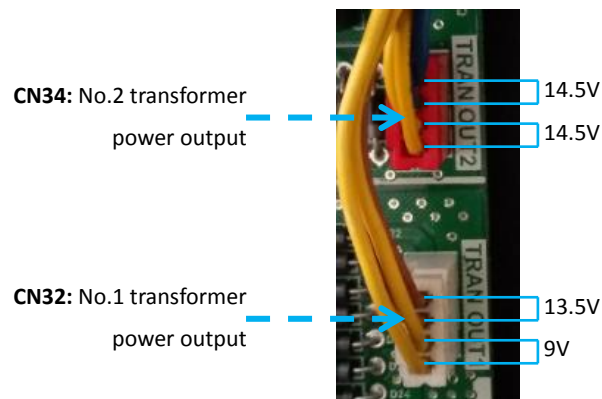

4.10 H2, H3 Troubleshooting

4.10.1 Digital display output

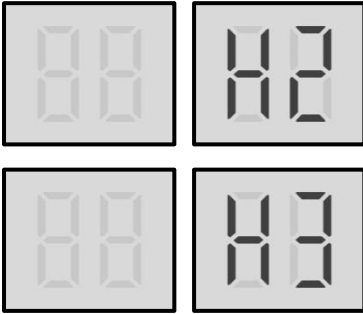

4.10.2 Description

- H2 indicates that the number of slave units detected by master unit has decreased.
- H3 indicates that the number of slave units detected by master unit has increased.
- All units stop running.
- Error code is only displayed on the master unit.

4.10.3 Possible causes

- Some outdoor units are powered off.
- Power supply abnormal.
- Incorrect outdoor unit address setting.
- Communication wires between outdoor units not connected properly.
- Loosened wiring within electric control box.
- Damaged main PCB or electric control box communication terminals block.

4.10.4 Procedure

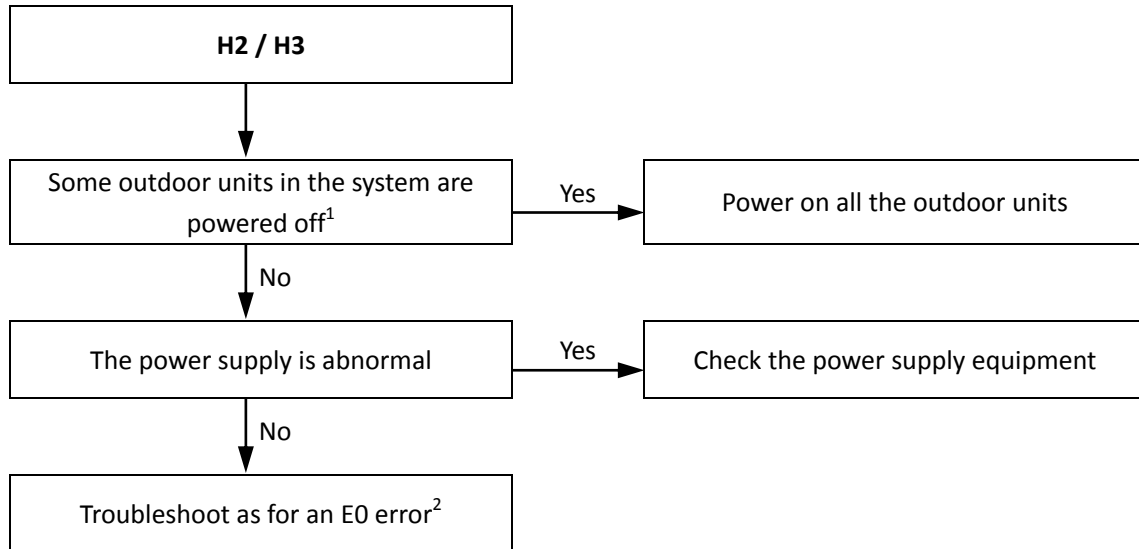

Notes:

1. Check LED1 on the main PCB. If LED1 is on, the main PCB is powered on, if LED1 is off, the main PCB is powered off. Refer to Figure 5-2.2 in Part 5, 2.3.1 "Layout".
2. See Part 5, 4.2 "E0 Troubleshooting".

4.11 xH4 Troubleshooting

4.11.1 Digital display output

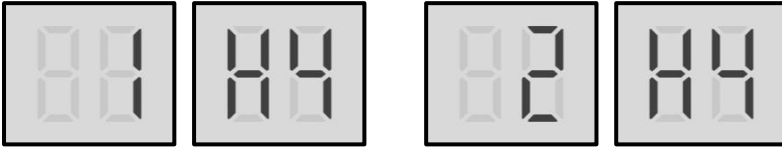

In the error code, 'x' is a placeholder for the compressor system (compressor and related electrical components), with 1 representing compressor system A and 2 representing compressor system B.

4.11.2 Description

- 1H4 indicates compressor A inverter module protection.
- 2H4 indicates compressor B inverter module protection.
- When an xH4 error occurs, a manual system restart is required before the system can resume operation. The cause of an xH4 error should be addressed promptly in order to avoid system damage.
- All units stop running.
- Error code is only displayed on the unit with the error.

4.11.3 Possible causes

- Inverter module protection.
- DC bus low or high voltage protection.
- MCE error.
- Zero speed protection.
- Phase sequence error.
- Excessive compressor frequency variation.
- Actual compressor frequency differs from target frequency.

4.11.4 Specific error codes for xH4 inverter module protection

If an xH4 error code is displayed, press button SW3 every two seconds until one of the following specific error codes is displayed on the digital display: xL0, xL1, xL2, xL4, xL5, xL7, xL8, xL9. Refer to Figure 5-4.3 and Table 5-4.1.

Figure 5-4.3: Button SW3 on main PCB

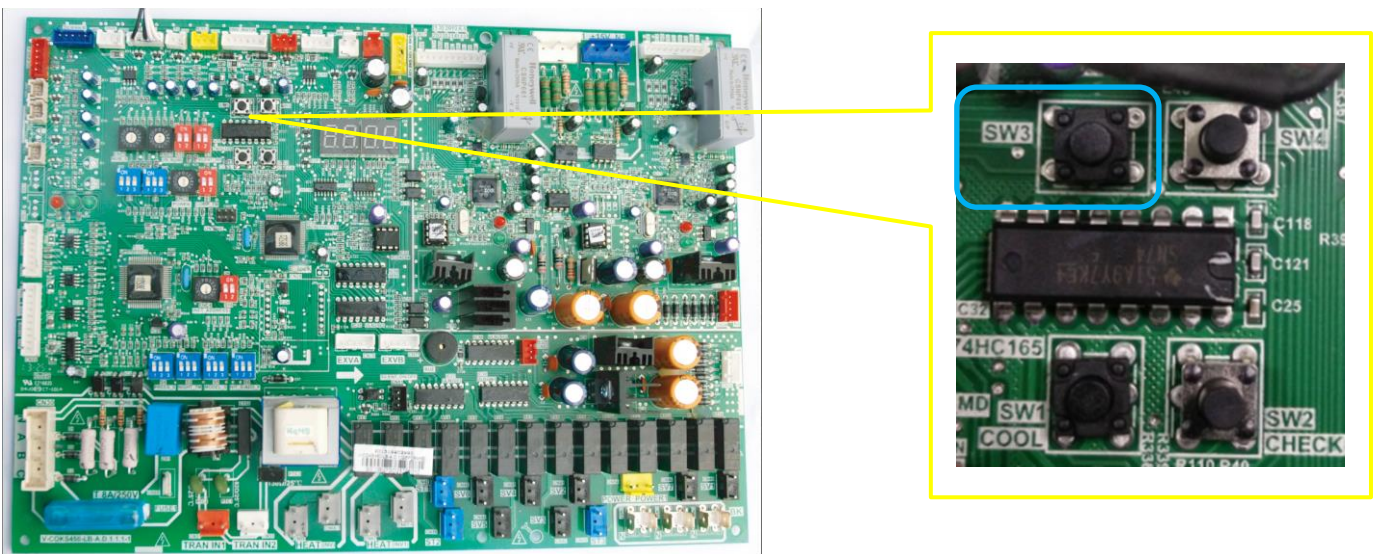

Table 5-4.1: Specific error codes for error xH4

Specific error code ¹	Content
xL0	Inverter module protection
xL1	DC bus low voltage protection
xL2	DC bus high voltage protection
xL4	MCE error
xL5	Zero speed protection
xL7	Phase sequence error
xL8	Compressor frequency variation greater than 15Hz within one second protection
xL9	Actual compressor frequency differs from target frequency by more than 15Hz protection

Notes:

- 'x' is a placeholder for the compressor system (compressor and related electrical components), with 1 representing compressor system A and 2 representing compressor system B.

The specific error codes xL0, xL1, xL2 and xL4 can also be obtained from the inverter module LED indicators. If an inverter module error has occurred, LED5/7 is continuously on and LED4/6 flashes. Refer to Figure 5-4.4 and Table 5-4.2.

Figure 5-4.4: LED indicators LED4 to LED7 on main PCB

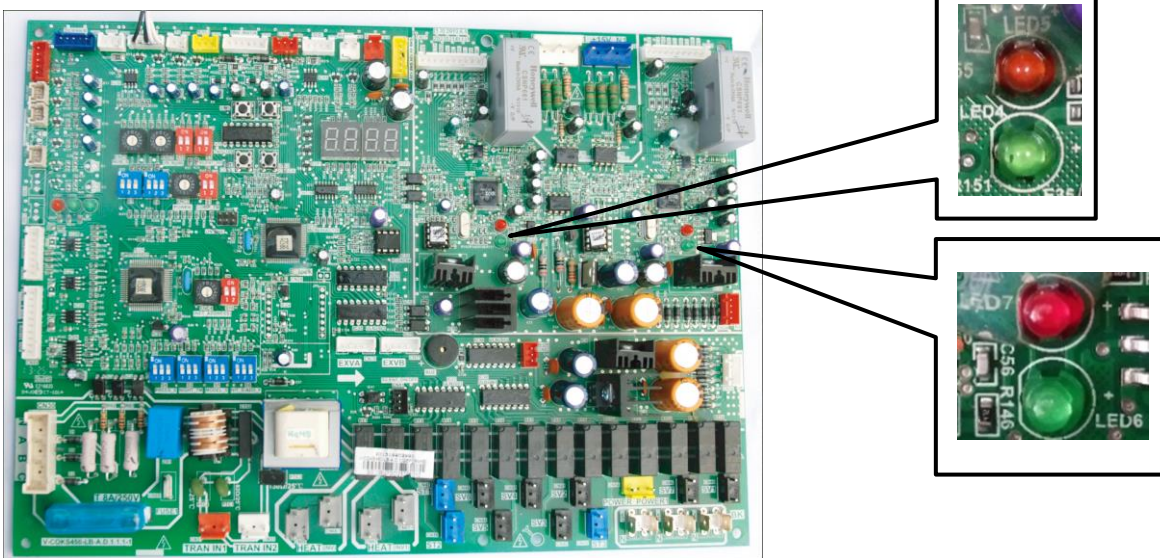

Table 5-4.2: Errors indicated on LED4/6

LED4/6 flashing pattern	Corresponding error
Flashes 8 times and stops for 1 second, then repeats	xL0 - Inverter module protection
Flashes 9 times and stops for 1 second, then repeats	xL1 - DC bus low voltage protection
Flashes 10 times and stops for 1 second, then repeats	xL2 - DC bus high voltage protection
Flashes 12 times and stops for 1 second, then repeats	xL4 - MCE error

4.11.5 First troubleshooting step

To troubleshoot xH4 errors, first ensure that the DC bus wire is connected correctly. The DC bus wire should run from the N terminal on the inverter module, through the current sensor (in the direction indicated by the arrow on the current sensor), and end at the N terminal on the DC filter board.

Figure 5-4.5: DC detection wire connection method

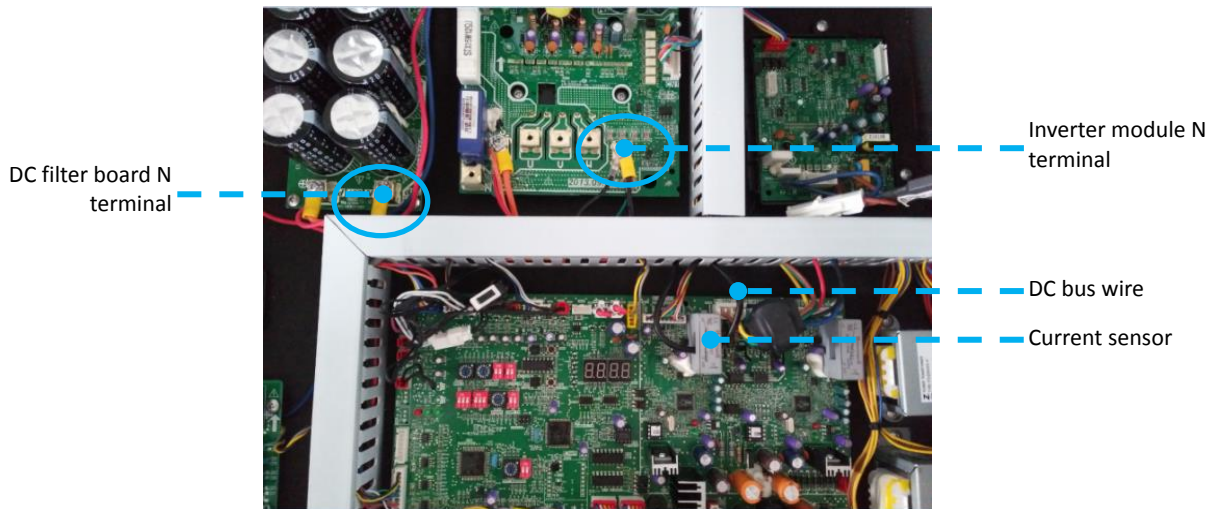

4.11.6 xL0 troubleshooting

Step 1: Check compressor

- Check that compressor wiring is all connected properly.
- The normal resistances of the inverter compressor are 0.7-1.5Ω among U V W and infinite between each of U V W and ground. If any of the resistances differ from these specifications, the compressor has malfunctioned.

Figure 5-4.6: Measuring resistances among compressor terminals

Figure 5-4.7: Measuring resistances between compressor terminals and ground



- If the resistances are normal, go to Step 2.

Step 2: Check inverter module

- The DC voltage between terminals P1 and N1 should be 1.41 times the local power supply voltage. The DC voltage between terminals P and N should be 510-580V. If either voltage is not in the normal range, troubleshoot as for xL1 or xL2 errors. Refer to Part 5, 4.11.7 “xL1/xL4 troubleshooting” or Part 5, 4.11.8 “xL2 troubleshooting”.
- Disconnect the terminals U, N, W from the inverter compressor. Measure the resistance among terminals P, N, U, V, W. All the resistances should be infinite. If any of them are not infinite, the inverter module is damaged and should be replaced.

Figure 5-4.8: Inverter module terminals

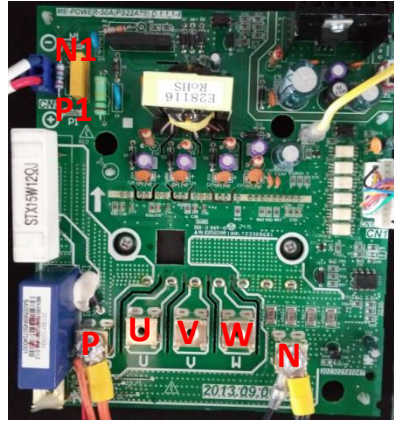

4.11.7 xL1/xL4 troubleshooting

Step 1: Check inverter module

- Check the DC voltage between terminals P and N. The normal value is 510-580V. If the voltage is lower than 510V, go to Step 2.

Figure 5-4.9: Inverter module terminals

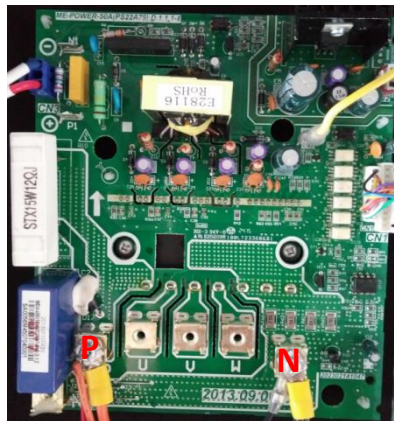

Step 2: Check rectifier wiring circuit

- If the wires are loose, fasten the wires. If the wires are OK, replace the main PCB.

Figure 5-4.10: Rectifier and AC filter board in electric control box

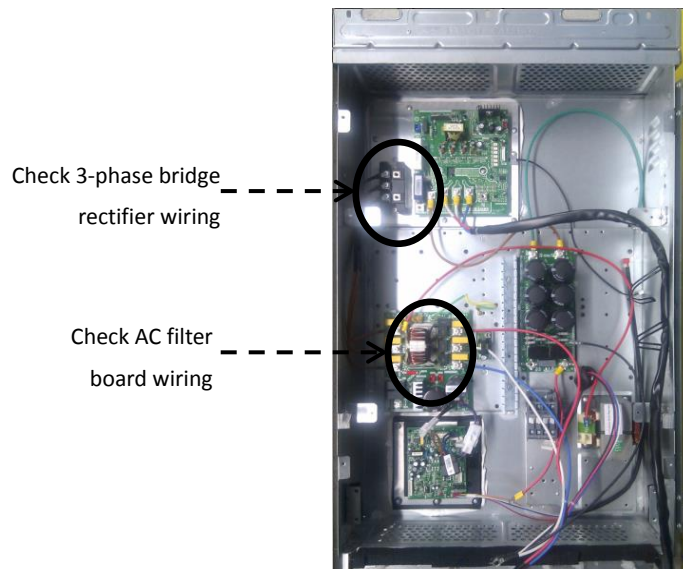

4.11.8 xL2 troubleshooting

Step 1: Check inverter module

- Check the DC voltage between terminals P and N. The normal value is 510-580V, if the voltage is higher than 580V, go to Step 2.

Figure 5-4.11: Inverter module terminals



Step 2: Check capacitor board

- Check the voltage between terminals P and N on the capacitor board. The normal value is 510-580V. If the voltage is not in the normal range, there is a problem with the electrolytic capacitor power supply. Check the power supply for high or unstable voltage. If the power supply voltage value is normal, then the main PCB has malfunctioned and needs to be replaced.

Figure 5-4.12: Capacitor board terminals

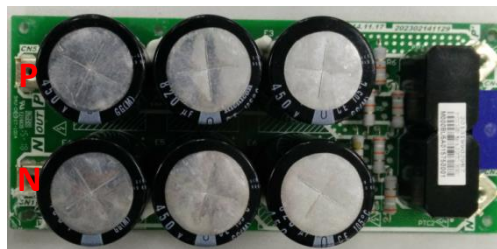

4.11.9 xL8/xL9 troubleshooting

Step 1: Check compressor

- The normal resistances of the inverter compressor are 0.7-1.5Ω among U V W and infinite between each of U V W and ground. If any of the resistances differ from these specifications, the compressor has malfunctioned.
- Refer to Figures 5-4.6 and 5-4.7 in Part 5, 4.11.6 “xL0 troubleshooting”. If the resistance values are normal, go to Step 2.

Step 2: Check compressor and main PCB

- If there is another unit nearby (either in the same system or another system) that is operating normally, its electric control box can be used to determine whether the xL8/xL9 error is being caused by a compressor fault or a main PCB fault:
 - If using another unit in the same system as the unit with the error to perform the test, set it as the master unit (address 0); if using a unit in another system, use the master unit.
 - Disconnect the power wires of the compressor referenced in the xL8/xL9 error code.
 - In the unit that is operating normally, disconnect the power wires that connect a compressor to the electric control box and use them to connect the compressor with the xL8/xL9 error to the electric control box of the unit that is operating normally. Ensure that the U, V, W terminals are connected in the right order, and then start the system that is operating normally.
 - If the compressor with the xL8/xL9 error runs normally, replace the main PCB of the unit with the xL8/xL9 error

and ensure the wiring is correct; if the compressor with the xL8/xL9 error still does not run normally, it needs to be replaced. Refer to Part 5, 4.11.10 “Compressor replacement procedure”.

Figure 5-4.13: Connecting compressor to an error-free unit

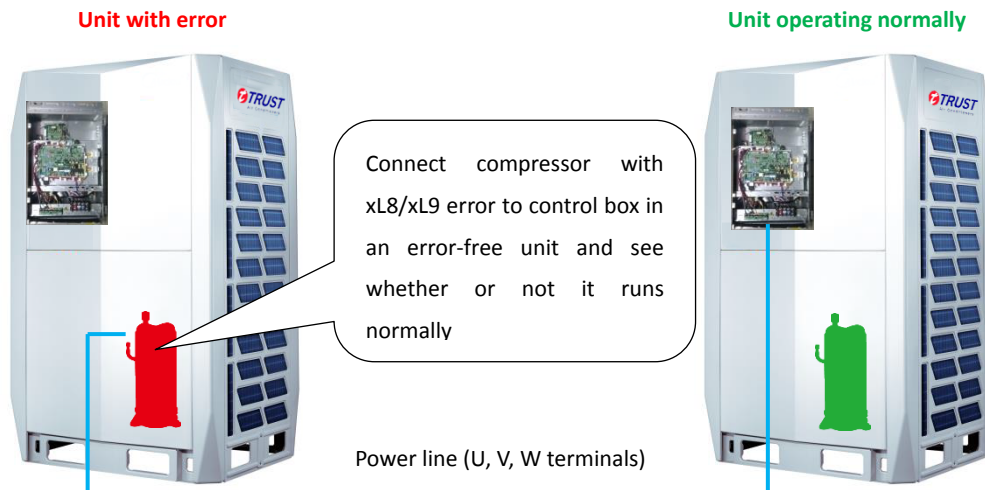

- If there is no error-free unit nearby:
 - Replace the main PCB of the unit with the xL8/xL9 error and ensure the wiring is correct. If the compressor with the xL8/xL9 error runs normally, a fault with the main PCB was causing the xL8/xL9 error; if the compressor with the xL8/xL9 error still does not run normally, it needs to be replaced. Refer to Part 5, 4.11.10 “Compressor replacement procedure”.

4.11.10 Compressor replacement procedure

Step 1: Remove faulty compressor and remove oil

- Remove the faulty compressor from the outdoor unit.
- Before removing the oil, shake the compressor so as to not allow impurities to remain settled at the bottom.
- Drain the oil out of the compressor and retain it for inspection. Normally the oil can be drained out from the compressor discharge pipe. Refer to Figure 5-4.14.

Figure 5-4.14: Draining oil from a compressor



Step 2: Inspect oil from faulty compressor

- The oil should be clear and transparent. Slightly yellow oil is not an indication of any problems. However, if the oil is dark, black or contains impurities, the system has problems and the oil needs to be changed. Refer to Figure 5-4.16 for further details regarding inspecting compressor oil. (If the compressor oil has been spoiled, the compressor will not be being lubricated effectively. The scroll plate, crankshaft and bearings will wear. Abrasion will lead to a larger load and higher current. More electric energy will get dissipated as heat and the temperature of the motor will become increasingly high. Finally, compressor damage or burnout will result. Refer to Figure 5-4.17.)

Step 3: Check oil in other compressors in the system

- If the oil drained from the faulty compressor is clean, go to Step 6.
- If the oil drained from the faulty compressor is only lightly spoiled, go to Step 4.
- If the oil drained from the faulty compressor is heavily spoiled, check the oil in the other compressors in the system. Drain the oil from any compressors where the oil has been spoiled. Go to Step 4.

Step 4: Replace oil separator(s) and accumulator(s)

- If the oil from a compressor is spoiled (lightly or heavily), drain the oil from the oil separator and accumulator in that unit and then replace them.

Step 5: Check filters(s)

- If the oil from a compressor is spoiled (lightly or heavily), check the filter between the gas stop valve and the 4-way valve in that unit. If it is blocked, clean with nitrogen or replace.

Step 6: Replace the faulty compressor and re-fit the other compressors

- Replace the faulty compressor.
- If the oil had been spoiled and was drained from the non-faulty compressors in Step 3, use clean oil to clean them before re-fitting them into the units. To clean, add oil into the compressor through the discharge pipe using a funnel, shake the compressor, and then drain the oil. Repeat several times and then re-fit the compressors into the units. (The discharge pipe is connected to the oil pool of the compressor by the inner oil balance pipe. Refer to Figure 5-4.15.)

Figure 5-4.15: Compressor piping



Step 7: Add compressor oil

- Add 1.2L of oil to the new compressor through the discharge pipe, using a funnel.
- Add 1.2L of oil to each of the compressors from which oil was drained in Step 3.
- Only use FVC68D oil. Different compressors require different types of oil. Using the wrong type of oil leads to various problems.
- Add additional oil to the accumulators such that the total amount of oil is 5L in 8-12HP units and 7L in 14-22HP units.

Step 8: Vacuum drying and refrigerant charging

- Once all the compressors and other components have been fully connected, vacuum dry the system and recharge refrigerant. Refer to the V5 X Engineering Data Book, Part 3.

Figure 5-4.16: Inspecting compressor oil

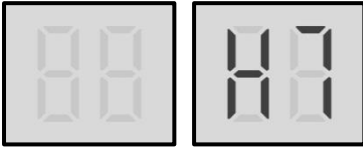

Figure 5-4.17: Effects of spoiled compressor oil



4.12 H7 Troubleshooting

4.12.1 Digital display output



4.12.2 Description

- Number of indoor units detected by master unit not same as number set on main PCB.
- All units stop running.
- Error code is only displayed on the master unit.

4.12.3 Possible causes

- Number of indoor units set on main PCB not same as actual number of indoor units.
- Some indoor units are powered off.
- Communication wires between indoor and outdoor units not connected properly.
- Indoor unit PCB damaged.
- Indoor unit without address or indoor unit address duplicated.
- Main PCB damaged.

4.12.4 Procedure

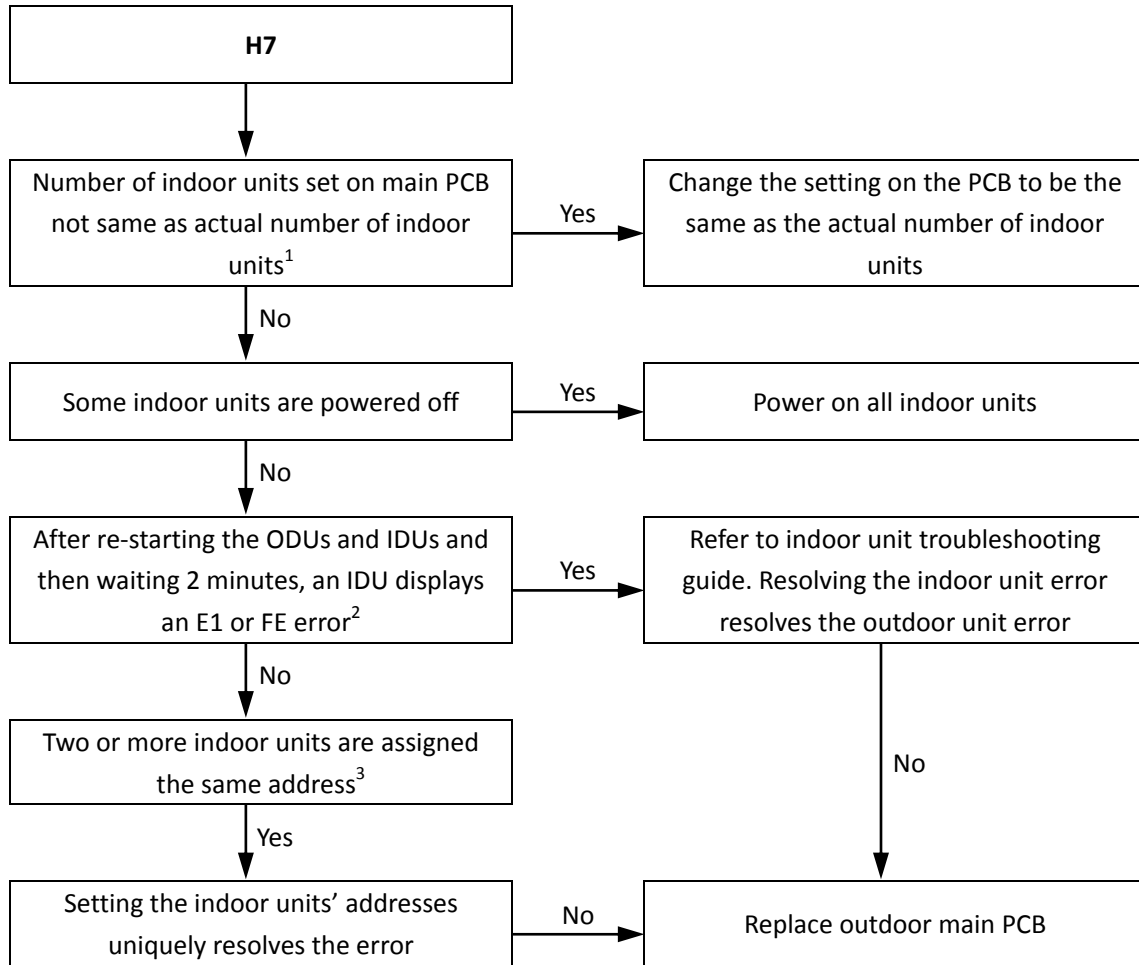

Notes:

1. The number of indoor units can be set on switches EN3 and S12 on the main PCB. Refer to Part 4, 1.1 "PCB Switches and Switch Settings".
2. Indoor unit error code E1 indicates a communication error between indoor and master unit. Indoor unit error code FE indicates that an indoor unit has not been assigned an address.
3. Indoor unit addresses can be checked and manually assigned using indoor unit remote/wired controllers. Alternatively, indoor unit addresses can be automatically assigned by the master outdoor unit. Auto-addressing mode is selected by setting switch S6 on the main PCB. Refer to Part 4, 1.1 "PCB Switches and Switch Settings".

4.13 H8 Troubleshooting

4.13.1 Digital display output

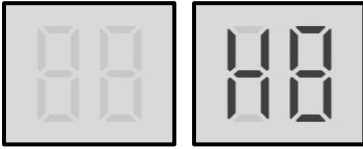

4.13.2 Description

- Discharge pipe low pressure protection. When the discharge pressure falls below 0.3MPa, the system displays H8 protection and all units stop running. When the discharge pressure returns to normal, H8 is removed and normal operation resumes.
- Error code is only displayed on the unit with the error.

4.13.3 Possible causes

- Outdoor unit stop valves are closed.
- Pressure sensor not connected properly or has malfunctioned.
- Insufficient refrigerant.
- Low pressure side blockage.
- Poor evaporator heat exchange.
- Main PCB damaged.

4.13.4 Procedure

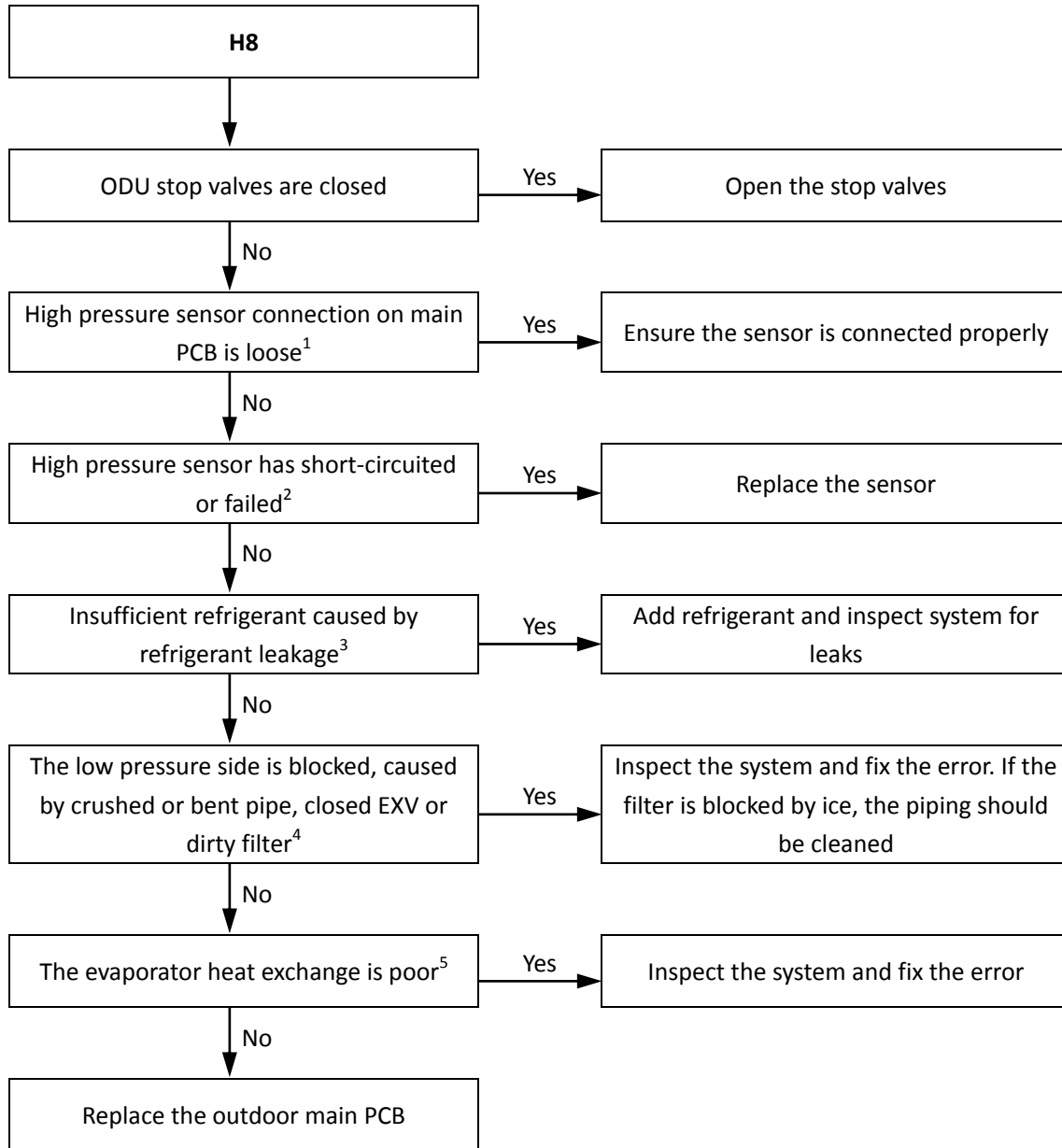

Notes:

1. High pressure sensor connection is port CN17 on the main PCB (labeled 30 in Figure 5-2.1 in Part 5, 2.2 "Ports").
2. Measure the resistance among the three terminals of the pressure sensor. If the resistance is of the order of mega Ohms or infinite, the pressure sensor has failed. Refer to Part 2, 1 "Layout of Functional Components".
3. To check for insufficient refrigerant:
 - Re-start the outdoor units. If an r1, r2 or r3 error is displayed upon start-up, there is insufficient refrigerant in the system.
 - An insufficiency of refrigerant causes compressor discharge temperature to be higher than normal, discharge and suction pressures to be lower than normal and compressor current to be lower than normal, and may cause frosting to occur on the suction pipe. These issues disappear once sufficient refrigerant has been charged into the system. For normal system parameters refer to Tables 5-5.4 and 5-5.5 in Part 5, 5.2 "5.2 Normal Operating Parameters of Refrigerant System".
4. A low pressure side blockage causes compressor discharge temperature to be higher than normal, suction pressure to be lower than normal and compressor current to be lower than normal, and may cause frosting to occur on the suction pipe. For normal system parameters refer to Tables 5-5.4 and 5-5.5 in Part 5, 5.2 "5.2 Normal Operating Parameters of Refrigerant System".
5. In cooling mode check indoor heat exchangers, fans and air outlets for dirt/blockages. In heating mode check outdoor heat exchangers, fans and air outlets for dirt/blockages.

4.14 yHd Troubleshooting

4.14.1 Digital display output

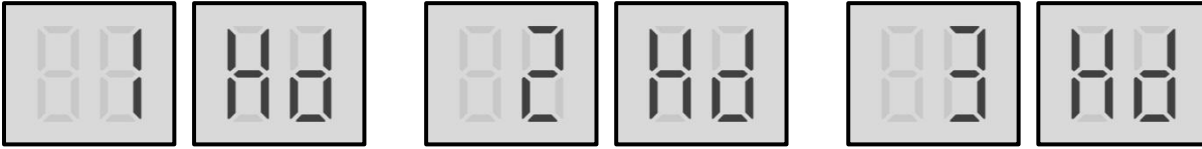

In the error code, 'y' is a placeholder for the address (1, 2 or 3) of the slave unit with the error.

4.14.2 Description

- 1Hd indicates an error on the slave unit with address 1.
- 2Hd indicates an error on the slave unit with address 2.
- 3Hd indicates an error on the slave unit with address 3.
- All units stop running.
- Error code is only displayed on the master unit.

4.14.3 Possible causes

- Slave unit malfunction.

4.14.4 Procedure

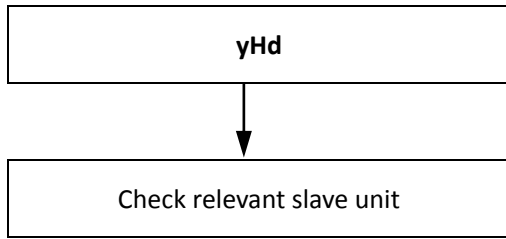

4.15 P0, P4, H6 Troubleshooting

4.15.1 Digital display output

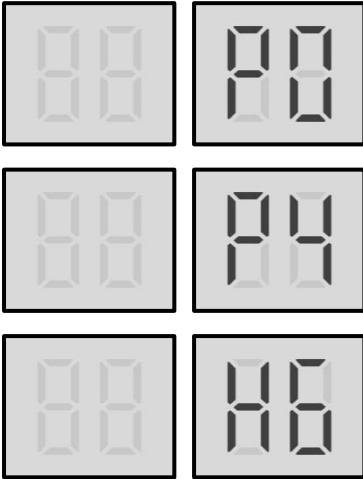

4.15.2 Description

- P0 indicates compressor temperature protection.
- P4 indicates discharge temperature protection. When the discharge temperature rises above 120°C the system displays P4 protection and all units stop running.
- H6 indicates P4 protection has occurred 3 times in 100 minutes. When an H6 error occurs, a manual system restart is required before the system can resume operation.
- Error code is only displayed on the unit with the error..

4.15.3 Possible causes

- Outdoor unit stop valves are closed.
- Temperature sensor/switch not connected properly or has malfunctioned.
- Insufficient refrigerant.
- System blockage.
- Indoor load too large.
- System contains air or nitrogen.
- Poor condenser heat exchange.
- Main PCB damaged.

4.15.4 Procedure

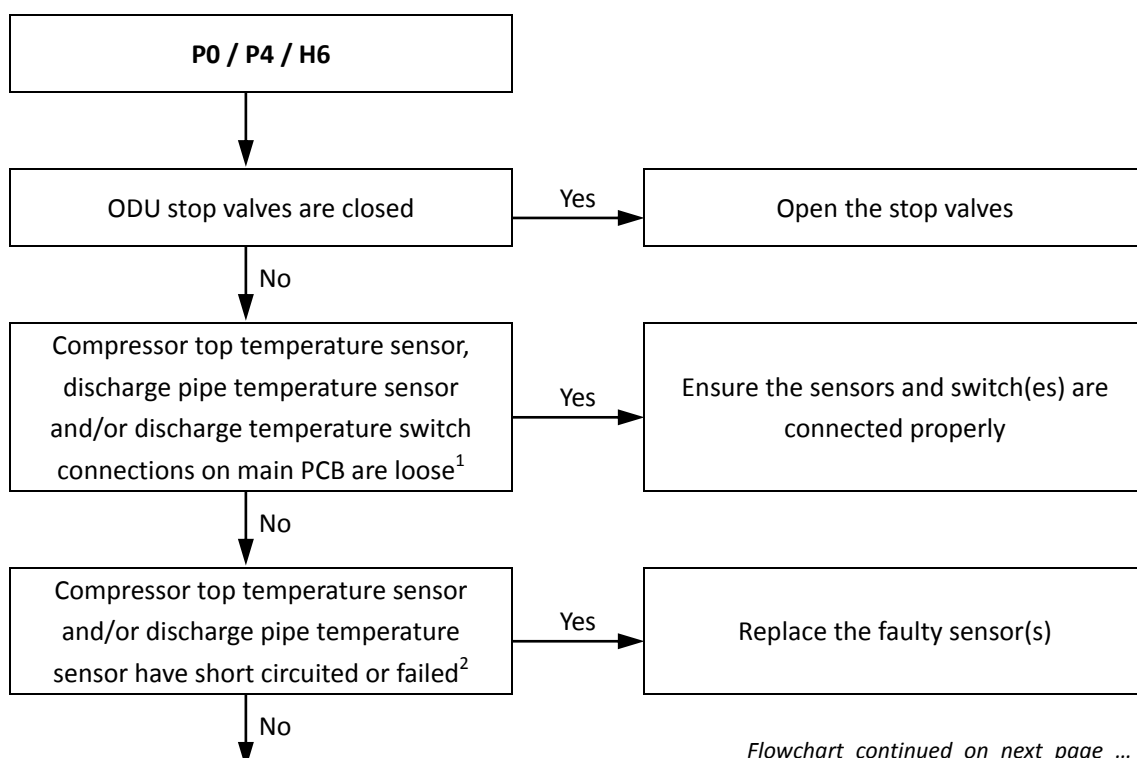

Flowchart continued on next page ...

... flowchart continued from previous page

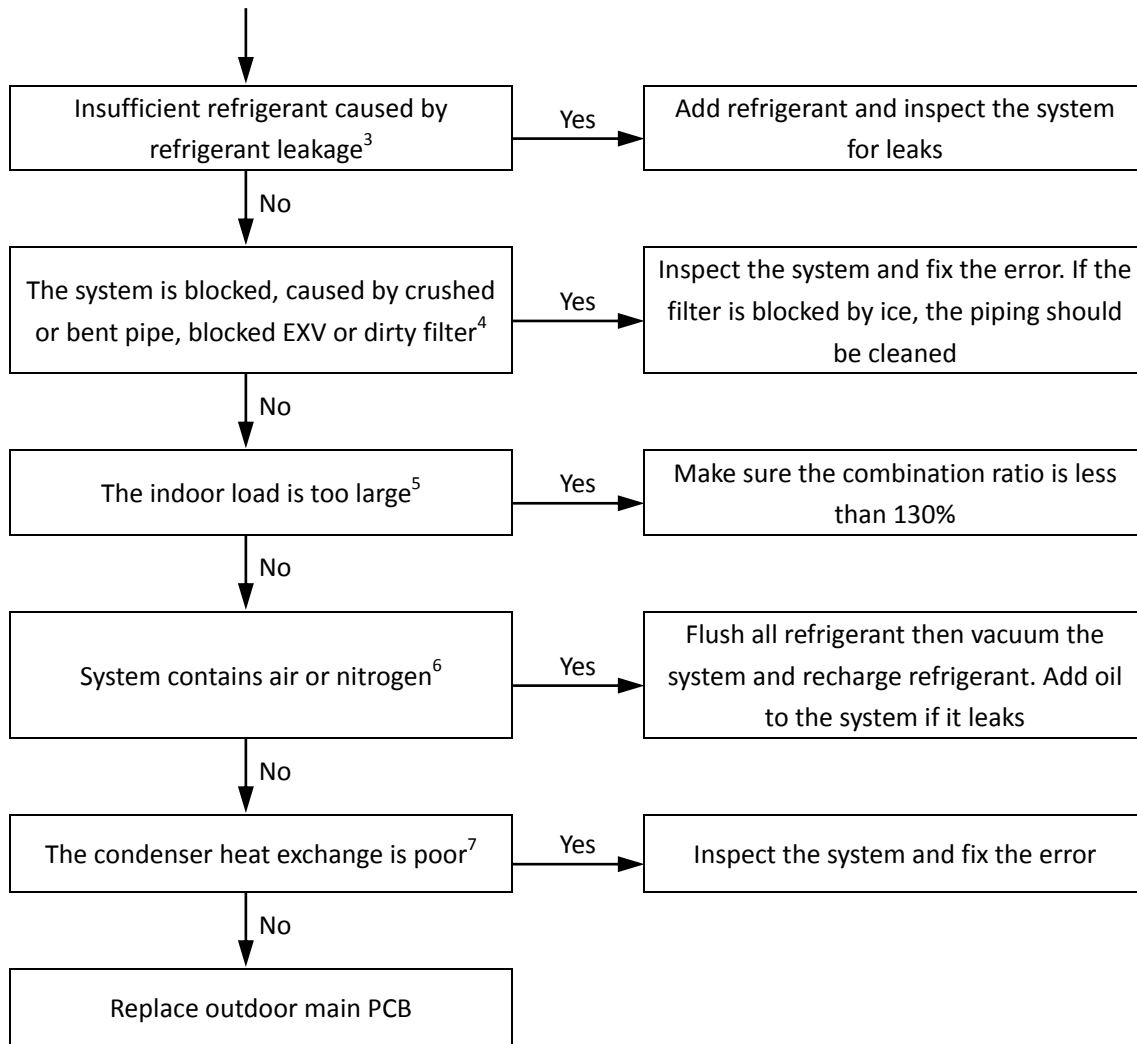

Notes:

1. Compressor top temperature sensor and discharge pipe temperature sensor connections are ports CN10 and CN11 on the main PCB (labeled 1 and 2, respectively, in Figure 5-2.1 in Part 5, 2.2 "Ports"). Discharge temperature switch connections are port CN18 on the main PCB (labeled 26 in Figure 5-2.1 in Part 5, 2.2 "Ports").
2. Measure sensor resistance. If the resistance is too low, the sensor has short-circuited. If the resistance is not consistent with the sensor's resistance characteristics table, the sensor has failed. Refer to Part 2, 1 "Layout of Functional Components" and to Table 5-5.2 in Part 5, 5.1 "Temperature Sensor Resistance Characteristics".
3. To check for insufficient refrigerant:
 - Re-start the outdoor units. If an r1, r2 or r3 error is displayed upon start-up, there is insufficient refrigerant in the system.
 - An insufficiency of refrigerant causes compressor discharge temperature to be higher than normal, discharge and suction pressures to be lower than normal and compressor current to be lower than normal, and may cause frosting to occur on the suction pipe. These issues disappear once sufficient refrigerant has been charged into the system. For normal system parameters refer to Tables 5-5.4 and 5-5.5 in Part 5, 5.2 "5.2 Normal Operating Parameters of Refrigerant System".
4. A low pressure side blockage causes compressor discharge temperature to be higher than normal, suction pressure to be lower than normal and compressor current to be lower than normal, and may cause frosting to occur on the suction pipe. For normal system parameters refer to Tables 5-5.4 and 5-5.5 in Part 5, 5.2 "5.2 Normal Operating Parameters of Refrigerant System".
5. An indoor load that is too large causes suction and discharge temperatures to be higher than normal. For normal system parameters refer to Tables 5-5.4 and 5-5.5 in Part 5, 5.2 "5.2 Normal Operating Parameters of Refrigerant System".
6. Air or nitrogen in the system causes discharge temperature to be higher than normal, discharge pressure to be higher than normal, compressor current to be higher than normal, abnormal compressor noise and an unsteady pressure meter reading. For normal system parameters refer to Tables 5-5.4 and 5-5.5 in Part 5, 5.2 "5.2 Normal Operating Parameters of Refrigerant System".
7. In cooling mode check outdoor heat exchangers, fans and air outlets for dirt/blockages. In heating mode check indoor heat exchangers, fans and air outlets for dirt/blockages.

4.16 P1 Troubleshooting

4.16.1 Digital display output

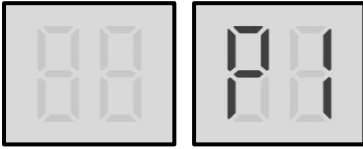

4.16.2 Description

- Discharge pipe high pressure protection. When the discharge pressure rises above 4.4MPa, the system displays P1 protection and all units stop running. When the discharge pressure falls below 3.2MPa, P1 is removed and normal operation resumes.
- If the system has a 3-phase protector and the 3-phase protector is connected with the high pressure switch, the system will display P1 protection when initially powered on, and P1 protection will disappear once the system reaches a steady state.
- Error code is only displayed on the unit with the error.

4.16.3 Possible causes

- Outdoor unit stop valves are closed.
- Pressure sensor/switch not connected properly or has malfunctioned.
- Excess refrigerant.
- System contains air or nitrogen.
- High pressure side blockage.
- Poor condenser heat exchange.
- Main PCB damaged.

4.16.4 Procedure

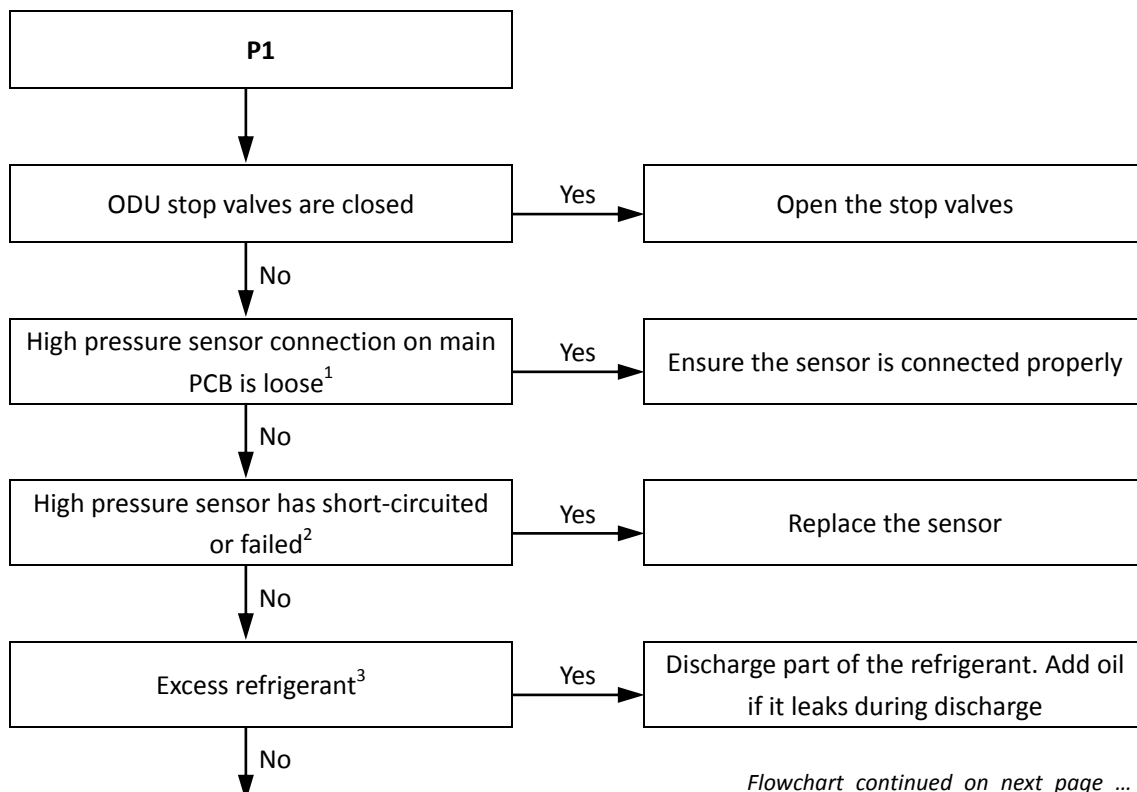

... flowchart continued from previous page

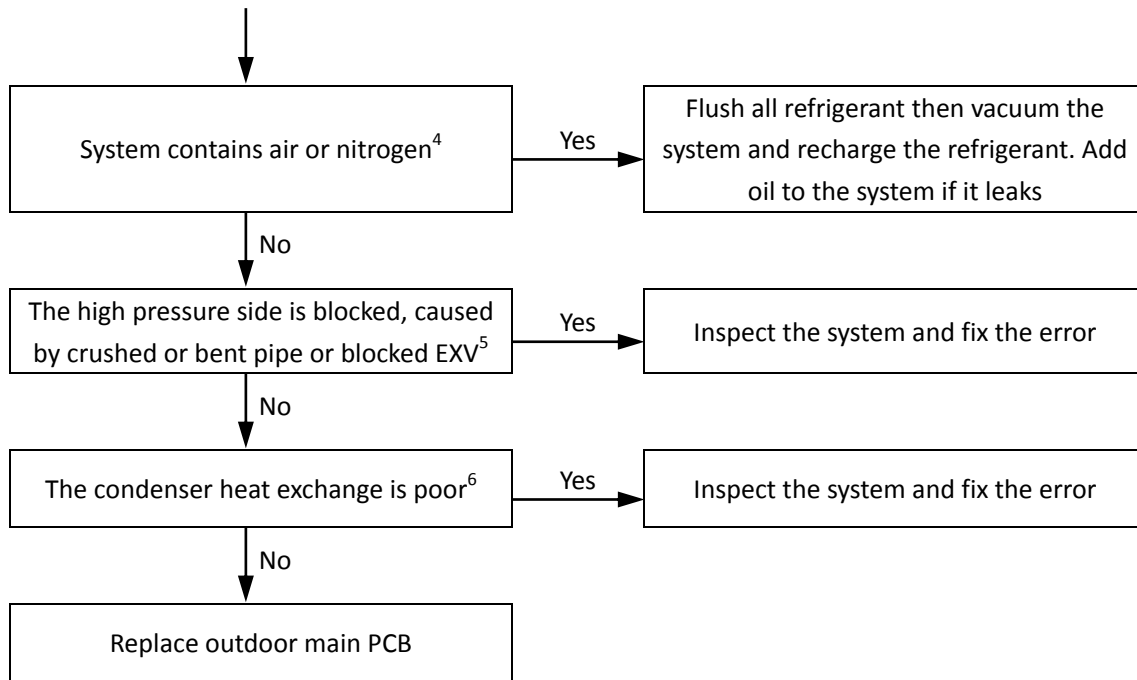

Notes:

1. High pressure sensor connection is port CN17 on the main PCB (labeled 30 in Figure 5-2.1 in Part 5, 2.2 "Ports").
2. Measure the resistance among the three terminals of the pressure sensor. If the resistance is of the order of mega Ohms or infinite, the pressure sensor has failed. Refer to Part 2, 1 "Layout of Functional Components".
3. To check for excess refrigerant:
 - Re-start the outdoor units. If an R1 or R2 error is displayed upon start-up, there is excess refrigerant in the system.
 - Excess refrigerant causes discharge temperature to be lower than normal, discharge pressure to be higher than normal and suction pressure to be higher than normal. For normal system parameters refer to Tables 5-5.4 and 5-5.5 in Part 5, 5.2 "5.2 Normal Operating Parameters of Refrigerant System".
4. Air or nitrogen in the system causes discharge temperature to be higher than normal, discharge pressure to be higher than normal, compressor current to be higher than normal, abnormal compressor noise and an unsteady pressure meter reading. For normal system parameters refer to Tables 5-5.4 and 5-5.5 in Part 5, 5.2 "5.2 Normal Operating Parameters of Refrigerant System".
5. High pressure side blockage causes discharge temperature to be higher than normal, discharge pressure to be higher than normal and suction pressure to be lower than normal. For normal system parameters refer to Tables 5-5.4 and 5-5.5 in Part 5, 5.2 "5.2 Normal Operating Parameters of Refrigerant System".
6. In cooling mode check outdoor heat exchangers, fans and air outlets for dirt/blockages. In heating mode check indoor heat exchangers, fans and air outlets for dirt/blockages.

4.17 P2, H5 Troubleshooting

4.17.1 Digital display output

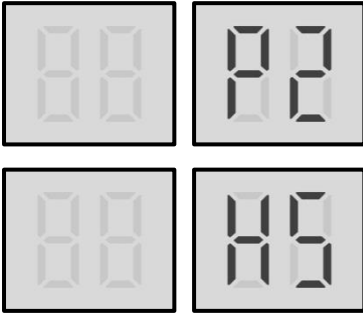

4.17.2 Description

- P2 indicates suction pipe low pressure protection. When the suction pressure falls below 0.05MPa, the system displays P2 protection and all units stop running. When the pressure rises above 0.15MPa, P2 is removed and normal operation resumes.
- H5 indicates P2 protection has occurred 3 times in 60 minutes. When an H5 error occurs, a manual system restart is required before the system can resume operation.
- If the system has a 3-phase protector and the 3-phase protector is connected to the low pressure switch, the system will display P2 protection when initially powered on, and P2 protection will disappear once the system reaches a steady state.
- Error code is only displayed on the unit with the error.

4.17.3 Possible causes

- Outdoor unit stop valves are closed.
- Insufficient refrigerant.
- Low pressure side blockage.
- Poor evaporator heat exchange.
- Main PCB damaged.

4.17.4 Procedure

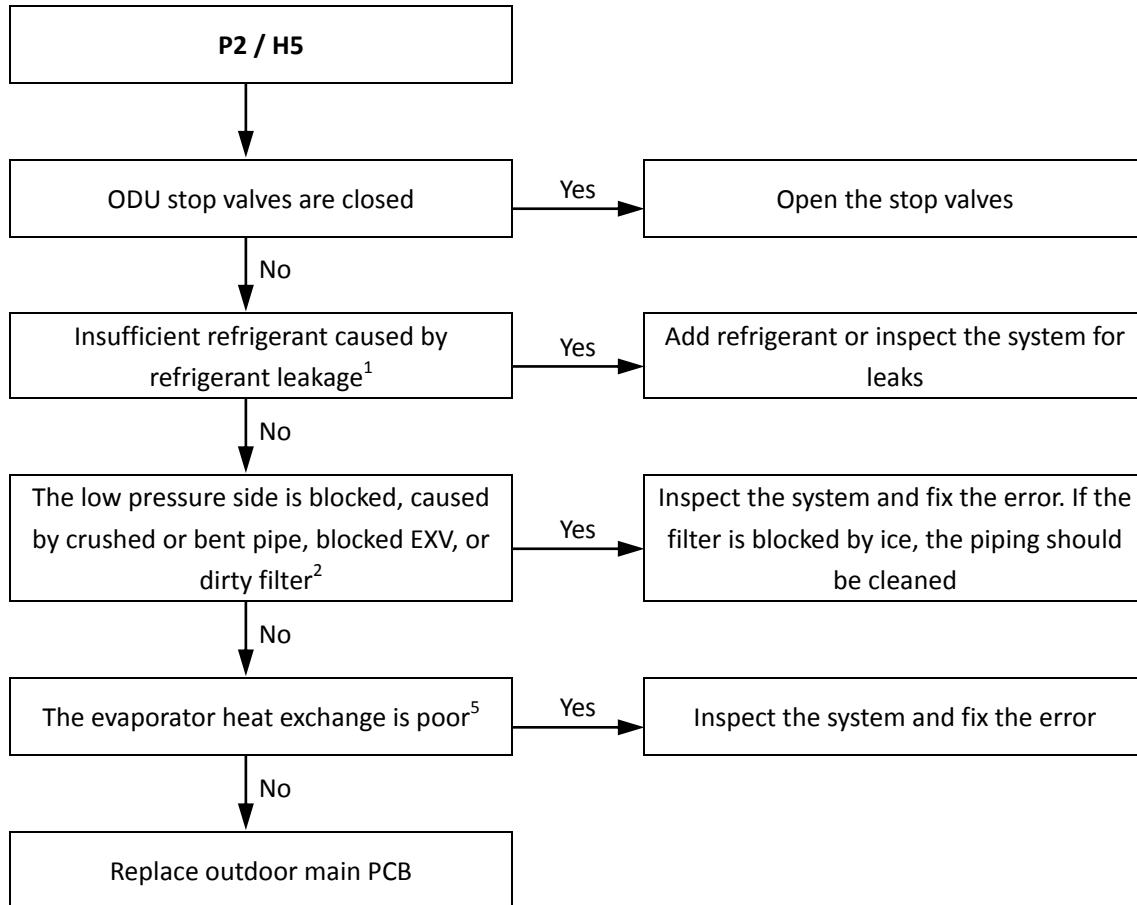

Notes:

1. To check for insufficient refrigerant:
 - Re-start the outdoor units. If an r1, r2 or r3 error is displayed upon start-up, there is insufficient refrigerant in the system.
 - An insufficiency of refrigerant causes compressor discharge temperature to be higher than normal, discharge and suction pressures to be lower than normal and compressor current to be lower than normal, and may cause frosting to occur on the suction pipe. These issues disappear once sufficient refrigerant has been charged into the system. For normal system parameters refer to Tables 5-5.4 and 5-5.5 in Part 5, 5.2 "5.2 Normal Operating Parameters of Refrigerant System".
2. A low pressure side blockage causes compressor discharge temperature to be higher than normal, suction pressure to be lower than normal and compressor current to be lower than normal, and may cause frosting to occur on the suction pipe. For normal system parameters refer to Tables 5-5.4 and 5-5.5 in Part 5, 5.2 "5.2 Normal Operating Parameters of Refrigerant System".
3. In cooling mode check indoor heat exchangers, fans and air outlets for dirt/blockages. In heating mode check outdoor heat exchangers, fans and air outlets for dirt/blockages.

4.18 xP3 Troubleshooting

4.18.1 Digital display output

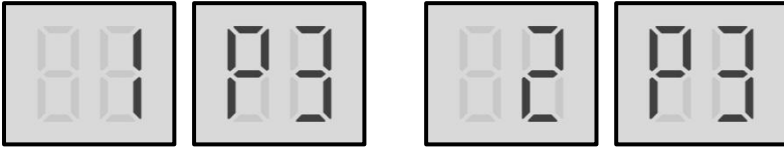

'x' is a placeholder for the compressor system (compressor and related electrical components), with 1 representing compressor system A and 2 representing compressor system B.

4.18.2 Description

- 1P3 indicates current protection on compressor A.
- 2P3 indicates current protection on compressor B.
- When the compressor current rises above the protection value (E705DHD-72: 23A; E655DHD-65: 21A; E405DHD-36: 12A; E405DHD-42: 15A), the system displays P3 protection and all units stop running. When the current returns to the normal range, P3 is removed and normal operation resumes.
- Error code is only displayed on the unit with the error.

4.18.3 Possible causes

- Outdoor unit stop valves are closed.
- Indoor load too large.
- Power supply abnormal.
- Sudden interruption of power to IDUs.
- Excess refrigerant.
- System contains air or nitrogen.
- Poor condenser heat exchange.
- High pressure side blockage.
- Inverter module damaged.
- Compressor damaged.
- Main PCB damaged.

4.18.4 Procedure

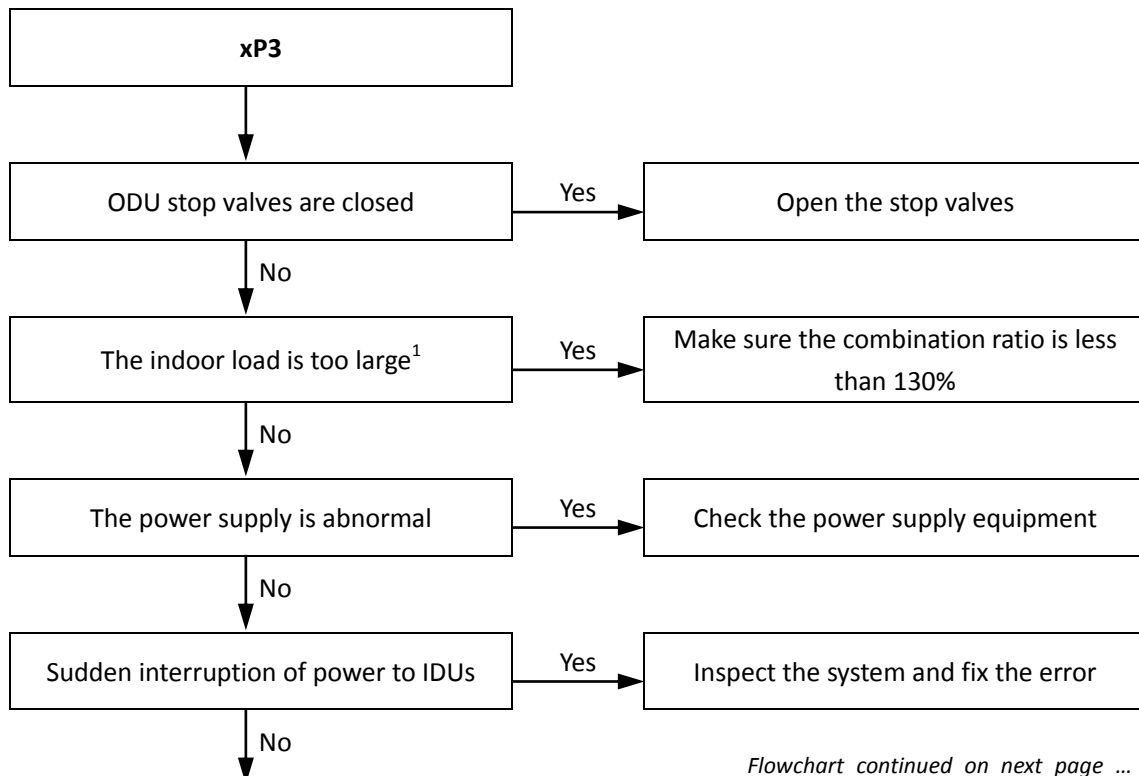

Flowchart continued on next page ...

... flowchart continued from previous page

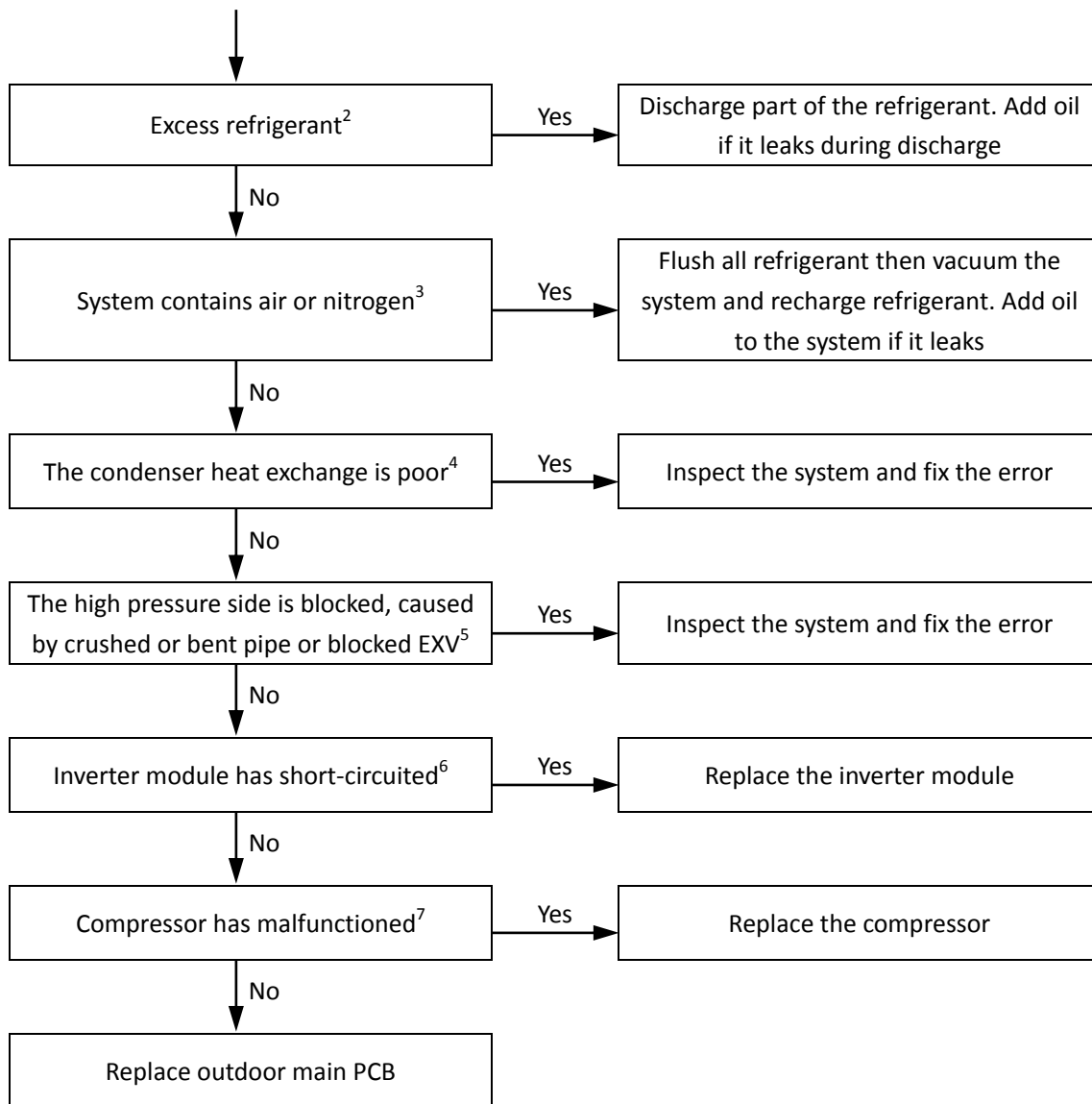

Notes:

1. An indoor load that is too large causes suction and discharge temperatures to be higher than normal. For normal system parameters refer to Tables 5-5.4 and 5-5.5 in Part 5, 5.2 "5.2 Normal Operating Parameters of Refrigerant System".
2. To check for excess refrigerant:
 - Re-start the outdoor units. If an R1 or R2 error is displayed upon start-up, there is excess refrigerant in the system.
 - Excess refrigerant causes discharge temperature to be lower than normal, discharge pressure to be higher than normal and suction pressure to be higher than normal. For normal system parameters refer to Tables 5-5.4 and 5-5.5 in Part 5, 5.2 "5.2 Normal Operating Parameters of Refrigerant System".
3. Air or nitrogen in the system causes discharge temperature to be higher than normal, discharge pressure to be higher than normal, compressor current to be higher than normal, abnormal compressor noise and an unsteady pressure meter reading. For normal system parameters refer to Tables 5-5.4 and 5-5.5 in Part 5, 5.2 "5.2 Normal Operating Parameters of Refrigerant System".
4. In cooling mode check outdoor heat exchangers, fans and air outlets for dirt/blockages. In heating mode check indoor heat exchangers, fans and air outlets for dirt/blockages.
5. High pressure side blockage causes discharge temperature to be higher than normal, discharge pressure to be higher than normal and suction pressure to be lower than normal. For normal system parameters refer to Tables 5-5.4 and 5-5.5 in Part 5, 5.2 "5.2 Normal Operating Parameters of Refrigerant System".
6. Set a multi-meter to buzzer mode and test any two terminals of P N and U V W of the inverter module. If the buzzer sounds, the inverter module has short-circuited. Refer to Figures 5-1.1 and 5-1.3 in Part 5, 1 "Outdoor Unit Electric Control Box Layout" and to Figure 5-4.1 in Part 5, 4.6 "E5 Troubleshooting".
7. The normal resistances of the inverter compressor are 0.7-1.5Ω among U V W and infinite between each of U V W and ground. If any of the resistances differ from these specifications, the compressor has malfunctioned. Refer to Figures 5-4.6 and 5-4.7 in Part 5, 4.11.6 "xL0 troubleshooting".

4.19 P5 Troubleshooting

4.19.1 Digital display output

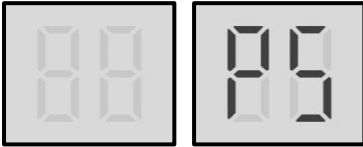

4.19.2 Description

- Outdoor heat exchanger temperature protection. When the outdoor heat exchanger temperature rises above 65°C, the system displays P5 protection and all units stop running. When the temperature returns to the normal range, P5 is removed and normal operation resumes.
- Error code is only displayed on the unit with the error.

4.19.3 Possible causes

- Outdoor unit stop valves are closed.
- Temperature sensor not connected properly or has malfunctioned.
- Indoor load too large.
- System contains air or nitrogen.
- Poor condenser heat exchange.
- High pressure side blockage.
- Main PCB damaged.

4.19.4 Procedure

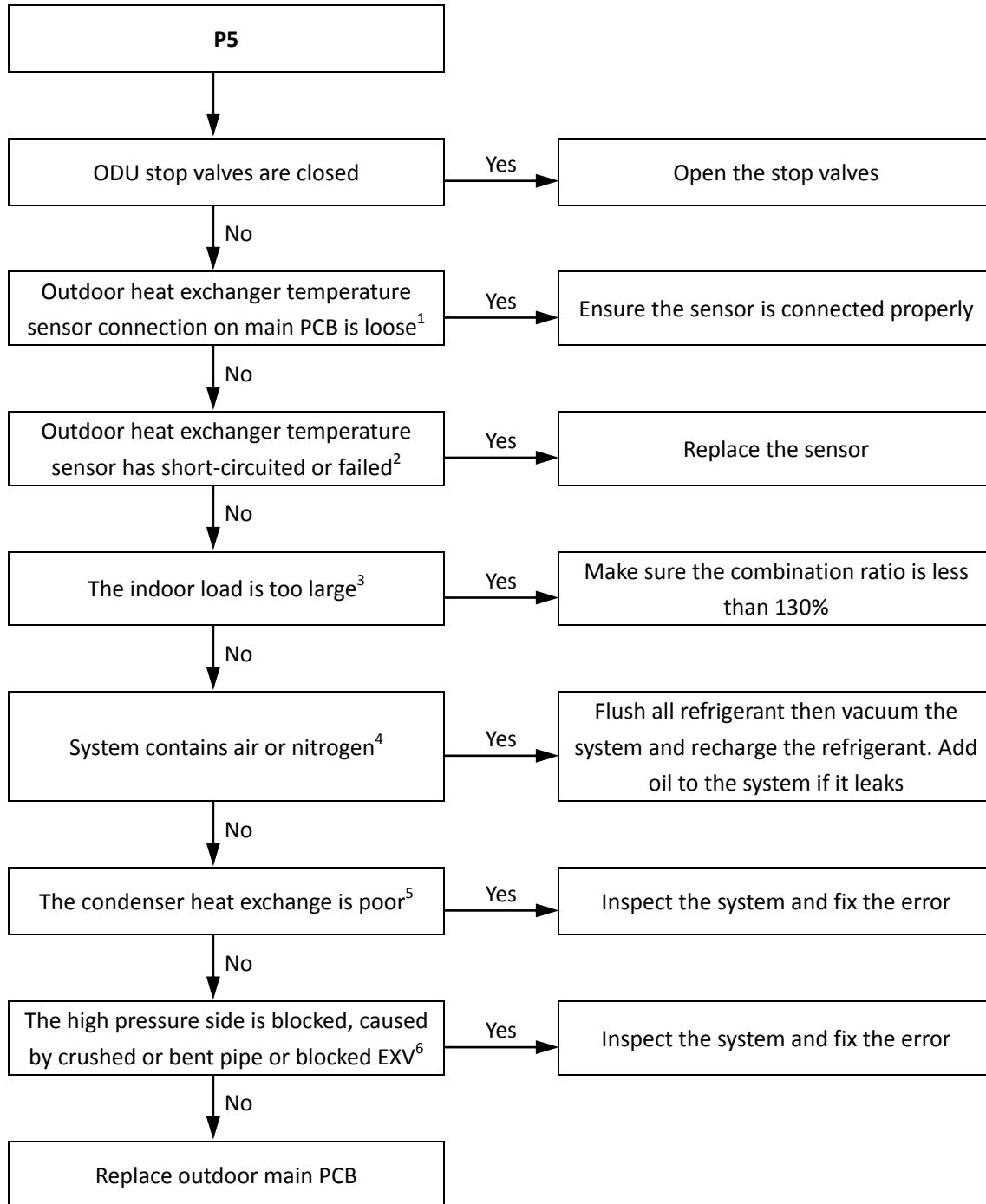

Notes:

1. Outdoor heat exchanger temperature sensor connection is port CN1 on the main PCB (labeled 32 in Figure 5-2.1 in Part 5, 2.2 "Ports").
2. Measure sensor resistance. If the resistance is too low, the sensor has short-circuited. If the resistance is not consistent with the sensor's resistance characteristics table, the sensor has failed. Refer to Part 2, 1 "Layout of Functional Components" and to Table 5-5.1 in Part 5, 5.1 "Temperature Sensor Resistance Characteristics".
3. An indoor load that is too large causes suction and discharge temperatures to be higher than normal. For normal system parameters refer to Tables 5-5.4 and 5-5.5 in Part 5, 5.2 "5.2 Normal Operating Parameters of Refrigerant System".
4. Air or nitrogen in the system causes discharge temperature to be higher than normal, discharge pressure to be higher than normal, compressor current to be higher than normal, abnormal compressor noise and an unsteady pressure meter reading. For normal system parameters refer to Tables 5-5.4 and 5-5.5 in Part 5, 5.2 "5.2 Normal Operating Parameters of Refrigerant System".
5. In cooling mode check outdoor heat exchangers, fans and air outlets for dirt/blockages. In heating mode check indoor heat exchangers, fans and air outlets for dirt/blockages.
6. High pressure side blockage causes discharge temperature to be higher than normal, discharge pressure to be higher than normal and suction pressure to be lower than normal. For normal system parameters refer to Tables 5-5.4 and 5-5.5 in Part 5, 5.2 "5.2 Normal Operating Parameters of Refrigerant System".

4.20 P9, H9 Troubleshooting

4.20.1 Digital display output

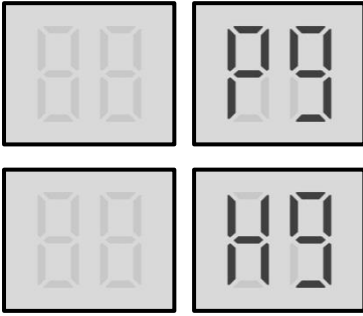

4.20.2 Description

- P9 indicates fan module protection. All units stop running.
- H9 indicates that P9 protection has occurred 3 times in 60 minutes. When an H9 error occurs, a manual system restart is required before the system can resume operation. The cause of an H9 error should be addressed promptly in order to avoid system damage.
- Error code is only displayed on the unit with the error.

4.20.3 Possible causes

- Switch ENC2 incorrectly set.
- Power or communication wires not connected properly.
- Fan motor blocked or has failed.
- Power supply abnormal.
- AC filter board damaged.
- Fan module damaged.
- Main PCB damaged.

4.20.4 Procedure

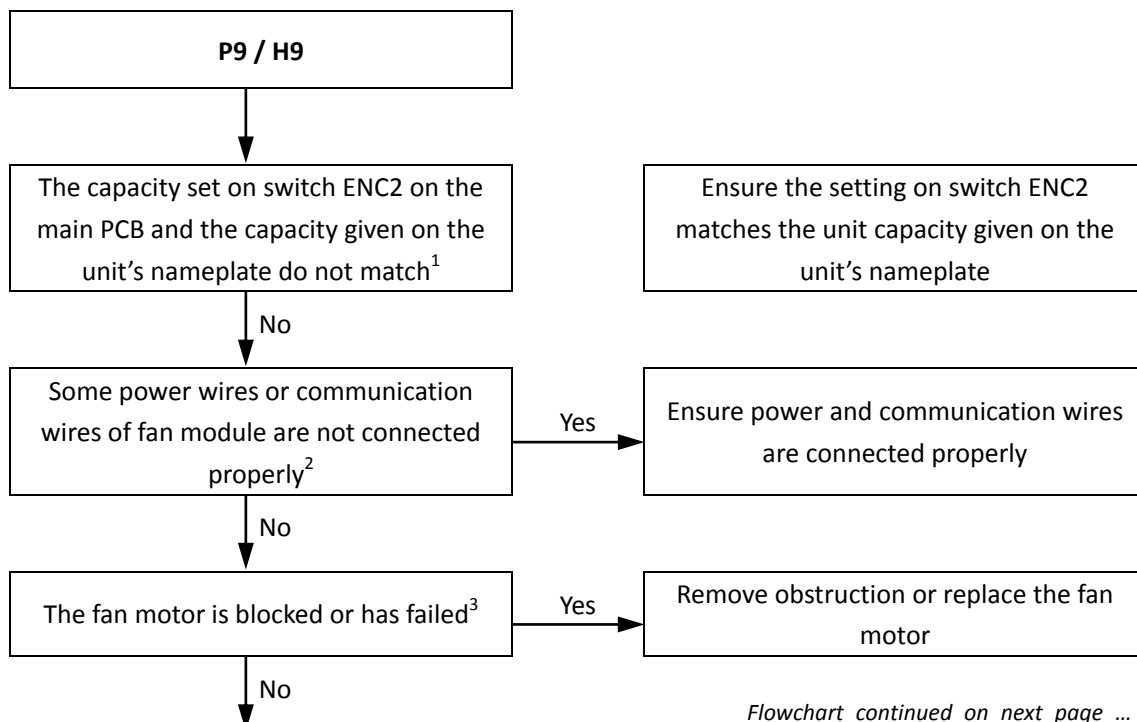

... flowchart continued from previous page

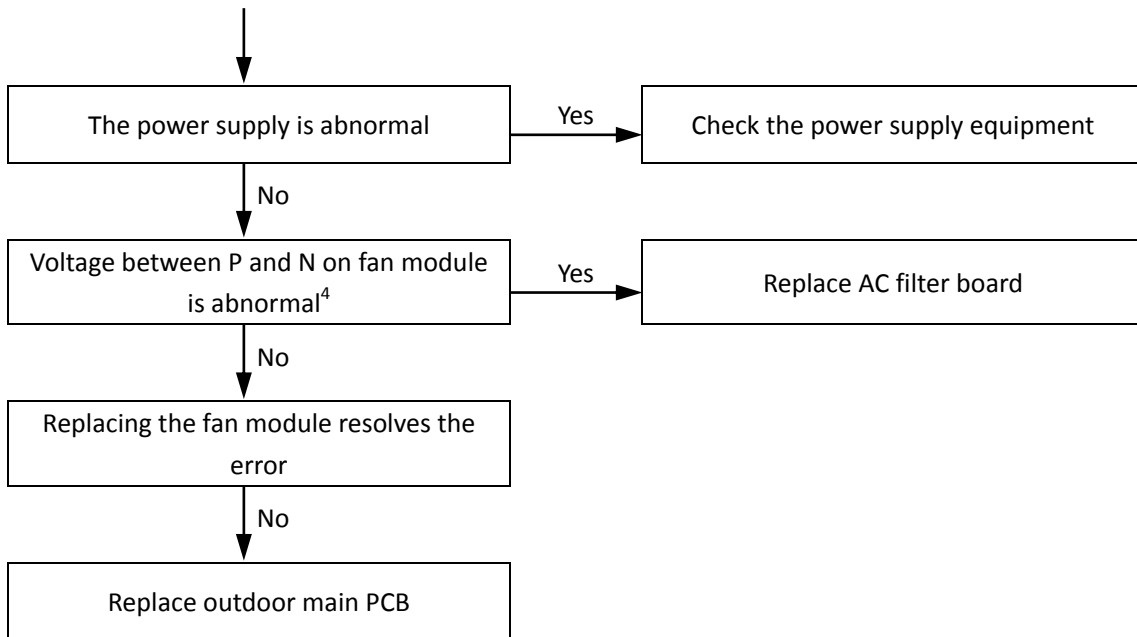

Notes:

1. Refer to Part 4, 1.1 "PCB Switches and Switch Settings".
2. Refer to Figures 5-1.1 and 5-1.3 in Part 5, 1 "Outdoor Unit Electric Control Box Layout" and to the V5 X Engineering Data Book, Part 2, 5 "Wiring Diagrams".
3. Refer to Part 2, 1 "Layout of Functional Components".
4. The normal voltage between P and N on the fan module is 310V DC. Refer to Figures 5-1.1 and 5-1.3 in Part 5, 1 "Outdoor Unit Electric Control Box Layout" and to Figure 5-4.18.

Figure 5-4.18: Fan module layout

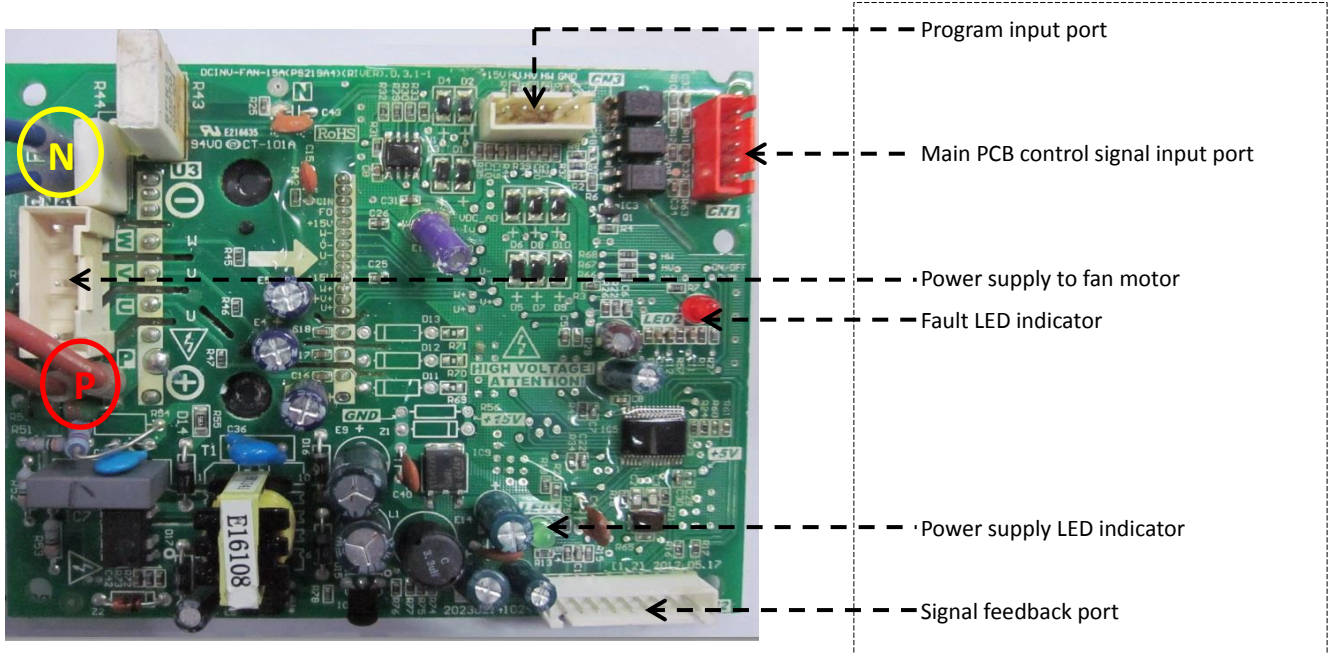

4.21 PL, C7 Troubleshooting

4.21.1 Digital display output

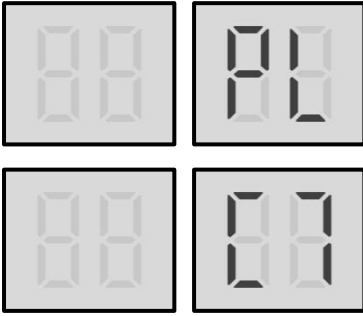

4.21.2 Description

- PL indicates inverter module temperature protection. When the main inverter module temperature rises above 80°C, the system displays PL protection and all units stop running.
- C7 indicates PL protection has occurred 3 times in 100 minutes. When a C7 error occurs, a manual system restart is required before the system can resume operation.
- Error code is only displayed on the unit with the error.

4.21.3 Possible causes

- Blocked, dirty or loose heat sink.
- Temperature sensor not connected properly or has malfunctioned.
- Main PCB damaged.

4.21.4 Procedure

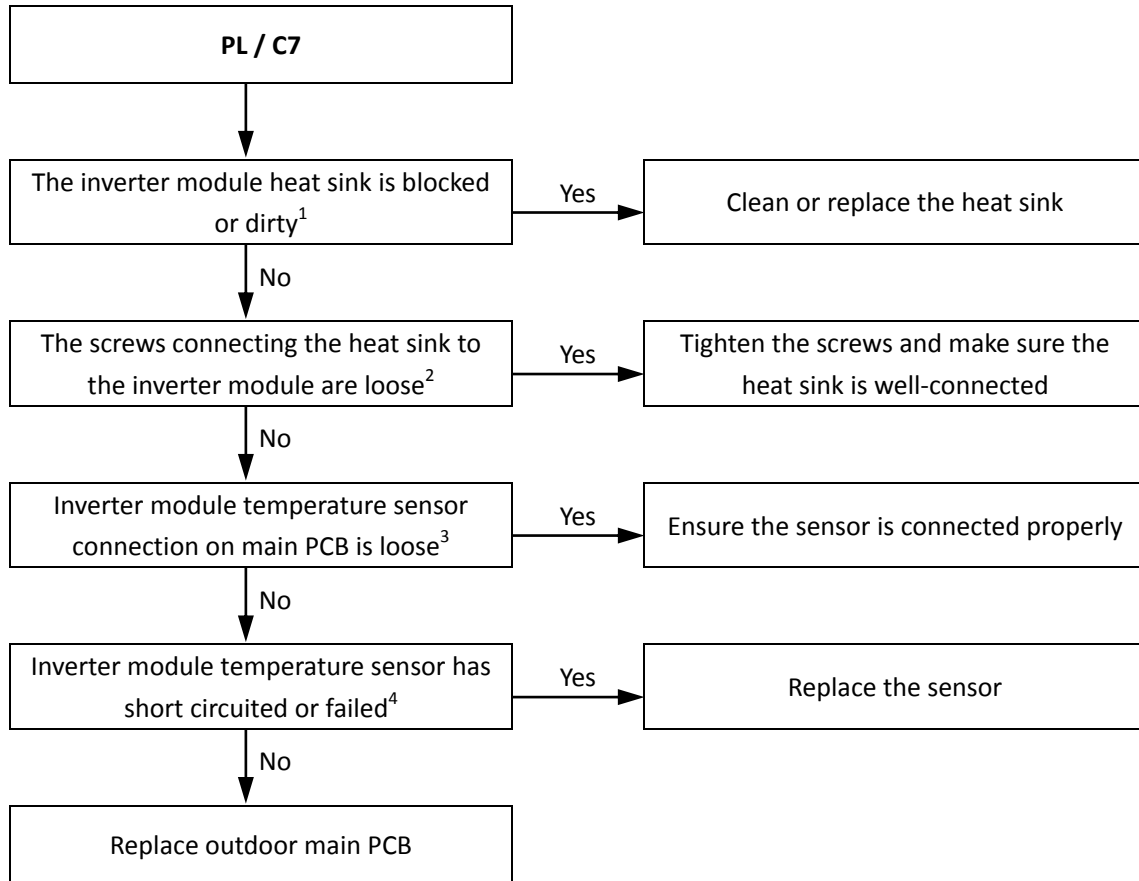

Notes:

1. Refer to Figures 5-1.1 and 5-1.3 in Part 5, 1 “Outdoor Unit Electric Control Box Layout”.
2. Refer to Figures 5-1.1 and 5-1.3 in Part 5, 1 “Outdoor Unit Electric Control Box Layout”.
3. Inverter module temperature sensor connection is port CN4 on the main PCB (labeled 3 in Figure 5-2.1 in Part 5, 2.2 “Ports”).
4. Measure sensor resistance. If the resistance is too low, the sensor has short-circuited. If the resistance is not consistent with the sensor’s resistance characteristics table, the sensor has failed. Refer to Figures 5-1.1 and 5-1.3 in Part 5, 1 “Outdoor Unit Electric Control Box Layout” and to Table 5-5.3 in Part 5, 5.1 “Temperature Sensor Resistance Characteristics”.

4.22 PP, F0 Troubleshooting

4.22.1 Digital display output

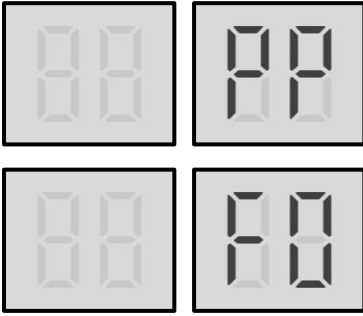

4.22.2 Description

- PP indicates compressor discharge insufficient superheat protection. When the discharge gas superheat is $\leq 0^{\circ}\text{C}$ for 20 minutes or $\leq 5^{\circ}\text{C}$ for 60 minutes, the system displays PP protection and all units stop running.
- F0 indicates PP protection has occurred 3 times in 150 minutes. When an F0 error occurs, a manual system restart is required before the system can resume operation.
- Error code is only displayed on the unit with the error.

4.22.3 Possible causes

- Temperature sensor not connected properly or has malfunctioned.
- Poor temperature sensor heat insulation.
- Excess refrigerant.
- Discharge pressure too high.
- Main PCB damaged.

4.22.4 Procedure

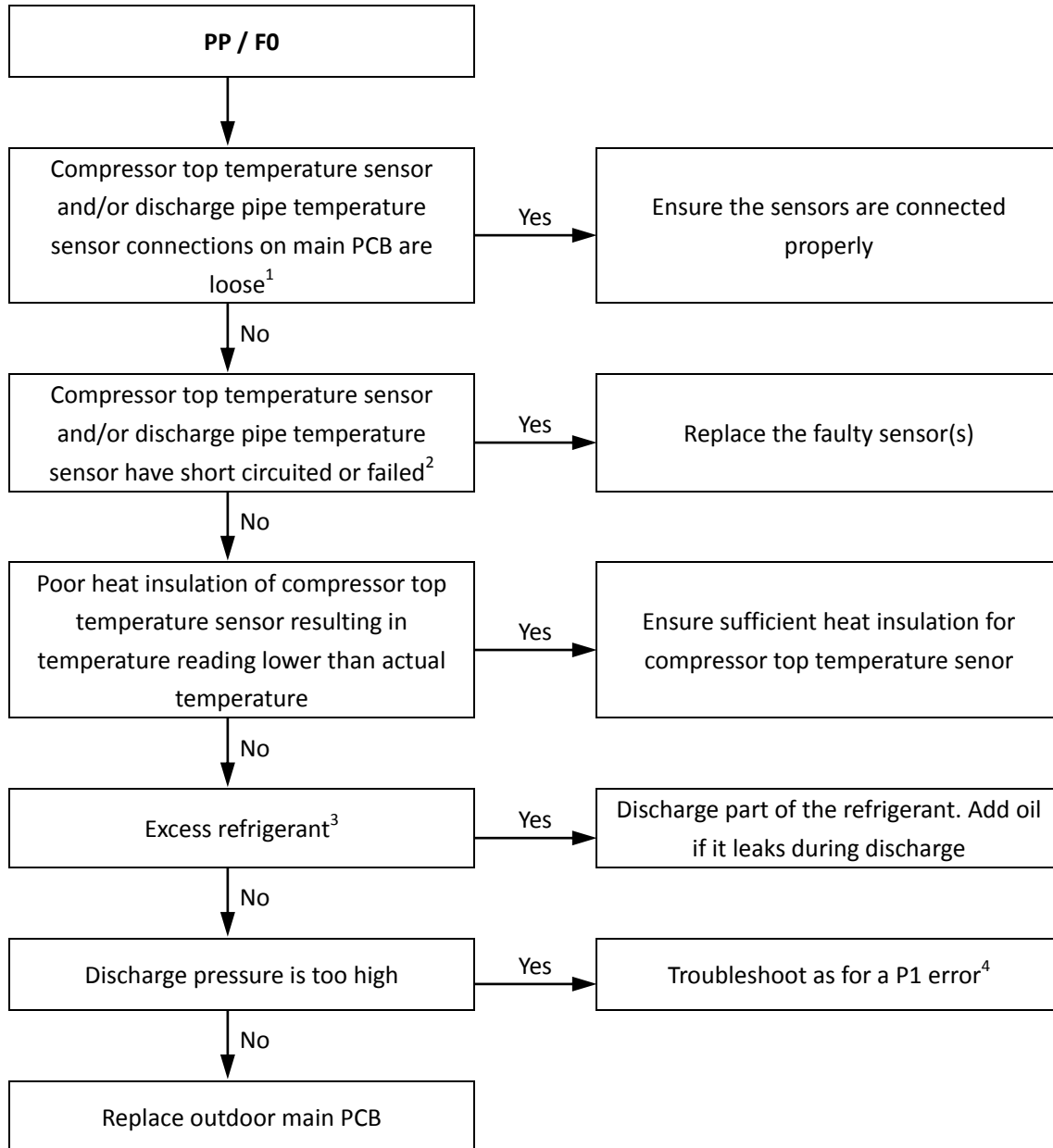

Notes:

1. Compressor top temperature sensor and discharge pipe temperature sensor connections are ports CN10 and CN11 on the main PCB (labeled 1 and 2, respectively, in Figure 5-2.1 in Part 5, 2.2 "Ports").
2. Measure sensor resistance. If the resistance is too low, the sensor has short-circuited. If the resistance is not consistent with the sensor's resistance characteristics table, the sensor has failed. Refer to Part 2, 1 "Layout of Functional Components" and to Table 5-5.2 in Part 5, 5.1 "Temperature Sensor Resistance Characteristics".
3. To check for excess refrigerant:
 - Re-start the outdoor units. If an R1 or R2 error is displayed upon start-up, there is excess refrigerant in the system.
 - Excess refrigerant causes discharge temperature to be lower than normal, discharge pressure to be higher than normal and suction pressure to be higher than normal. For normal system parameters refer to Tables 5-5.4 and 5-5.5 in Part 5, 5.2 "5.2 Normal Operating Parameters of Refrigerant System".
4. See Part 5, 4.16 "P1 Troubleshooting".

5 Appendix to Part 5

5.1 Temperature Sensor Resistance Characteristics

Table 5-5.1: Outdoor ambient temperature sensor and outdoor heat exchanger temperature sensor resistance characteristics

Temperature (°C)	Resistance (kΩ)	Temperature (°C)	Resistance (kΩ)	Temperature (°C)	Resistance (kΩ)	Temperature (°C)	Resistance (kΩ)
-20	115.3	20	12.64	60	2.358	100	0.6297
-19	108.1	21	12.06	61	2.272	101	0.6115
-18	101.5	22	11.50	62	2.191	102	0.5939
-17	96.34	23	10.97	63	2.112	103	0.5768
-16	89.59	24	10.47	64	2.037	104	0.5604
-15	84.22	25	10.00	65	1.965	105	0.5445
-14	79.31	26	9.551	66	1.896	106	0.5291
-13	74.54	27	9.124	67	1.830	107	0.5143
-12	70.17	28	8.720	68	1.766	108	0.4999
-11	66.09	29	8.336	69	1.705	109	0.4860
-10	62.28	30	7.971	70	1.647	110	0.4726
-9	58.71	31	7.624	71	1.591	111	0.4596
-8	56.37	32	7.295	72	1.537	112	0.4470
-7	52.24	33	6.981	73	1.485	113	0.4348
-6	49.32	34	6.684	74	1.435	114	0.4230
-5	46.57	35	6.400	75	1.387	115	0.4116
-4	44.00	36	6.131	76	1.341	116	0.4006
-3	41.59	37	5.874	77	1.291	117	0.3899
-2	39.82	38	5.630	78	1.254	118	0.3796
-1	37.20	39	5.397	79	1.2133	119	0.3695
0	35.20	40	5.175	80	1.174	120	0.3598
1	33.33	41	4.964	81	1.136	121	0.3504
2	31.56	42	4.763	82	1.100	122	0.3413
3	29.91	43	4.571	83	1.064	123	0.3325
4	28.35	44	4.387	84	1.031	124	0.3239
5	26.88	45	4.213	85	0.9982	125	0.3156
6	25.50	46	4.046	86	0.9668	126	0.3075
7	24.19	47	3.887	87	0.9366	127	0.2997
8	22.57	48	3.735	88	0.9075	128	0.2922
9	21.81	49	3.590	89	0.8795	129	0.2848
10	20.72	50	3.451	90	0.8525	130	0.2777
11	19.69	51	3.318	91	0.8264	131	0.2708
12	18.72	52	3.192	92	0.8013	132	0.2641
13	17.80	53	3.071	93	0.7771	133	0.2576
14	16.93	54	2.959	94	0.7537	134	0.2513
15	16.12	55	2.844	95	0.7312	135	0.2451
16	15.34	56	2.738	96	0.7094	136	0.2392
17	14.62	57	2.637	97	0.6884	137	0.2334
18	13.92	58	2.540	98	0.6682	138	0.2278
19	13.26	59	2.447	99	0.6486	139	0.2223

Table 5-5.2: Compressor top temperature sensor and discharge pipe temperature sensor resistance characteristics

Temperature (°C)	Resistance (kΩ)	Temperature (°C)	Resistance (kΩ)	Temperature (°C)	Resistance (kΩ)	Temperature (°C)	Resistance (kΩ)
-20	542.7	20	68.66	60	13.59	100	3.702
-19	511.9	21	65.62	61	13.11	101	3.595
-18	483.0	22	62.73	62	12.65	102	3.492
-17	455.9	23	59.98	63	12.21	103	3.392
-16	430.5	24	57.37	64	11.79	104	3.296
-15	406.7	25	54.89	65	11.38	105	3.203
-14	384.3	26	52.53	66	10.99	106	3.113
-13	363.3	27	50.28	67	10.61	107	3.025
-12	343.6	28	48.14	68	10.25	108	2.941
-11	325.1	29	46.11	69	9.902	109	2.860
-10	307.7	30	44.17	70	9.569	110	2.781
-9	291.3	31	42.33	71	9.248	111	2.704
-8	275.9	32	40.57	72	8.940	112	2.630
-7	261.4	33	38.89	73	8.643	113	2.559
-6	247.8	34	37.30	74	8.358	114	2.489
-5	234.9	35	35.78	75	8.084	115	2.422
-4	222.8	36	34.32	76	7.820	116	2.357
-3	211.4	37	32.94	77	7.566	117	2.294
-2	200.7	38	31.62	78	7.321	118	2.233
-1	190.5	39	30.36	79	7.086	119	2.174
0	180.9	40	29.15	80	6.859	120	2.117
1	171.9	41	28.00	81	6.641	121	2.061
2	163.3	42	26.90	82	6.430	122	2.007
3	155.2	43	25.86	83	6.228	123	1.955
4	147.6	44	24.85	84	6.033	124	1.905
5	140.4	45	23.89	85	5.844	125	1.856
6	133.5	46	22.89	86	5.663	126	1.808
7	127.1	47	22.10	87	5.488	127	1.762
8	121.0	48	21.26	88	5.320	128	1.717
9	115.2	49	20.46	89	5.157	129	1.674
10	109.8	50	19.69	90	5.000	130	1.632
11	104.6	51	18.96	91	4.849		
12	99.69	52	18.26	92	4.703		
13	95.05	53	17.58	93	4.562		
14	90.66	54	16.94	94	4.426		
15	86.49	55	16.32	95	4.294		
16	82.54	56	15.73	96	4.167		
17	78.79	57	15.16	97	4.045		
18	75.24	58	14.62	98	3.927		
19	71.86	59	14.09	99	3.812		

Table 5-5.3: Inverter module temperature sensor resistance characteristics

Temperature (°C)	Resistance (kΩ)	Temperature (°C)	Resistance (kΩ)	Temperature (°C)	Resistance (kΩ)	Temperature (°C)	Resistance (kΩ)
-30	971.4	10	109.0	50	19.70	90	5.000
-29	912.8	11	103.9	51	18.97	91	4.855
-28	858.2	12	99.02	52	18.26	92	4.705
-27	807.3	13	94.44	53	17.59	93	4.566
-26	759.7	14	90.11	54	16.94	94	4.431
-25	715.3	15	86.00	55	16.32	95	4.301
-24	673.6	16	82.09	56	15.73	96	4.176
-23	634.7	17	78.38	57	15.16	97	4.055
-22	598.2	18	74.87	58	14.62	98	3.938
-21	564.1	19	71.53	59	14.10	99	3.825
-20	532.2	20	68.36	60	13.60	100	3.716
-19	502.2	21	65.34	61	13.12	101	3.613
-18	474.1	22	62.47	62	12.65	102	3.514
-17	447.7	23	59.75	63	12.22	103	3.418
-16	423.0	24	57.17	64	11.79	104	3.326
-15	399.8	25	54.71	65	11.39	105	3.235
-14	378.0	26	52.36	66	10.99	106	3.148
-13	357.5	27	50.13	67	10.62	107	3.063
-12	338.2	28	48.01	68	10.25	108	2.982
-11	320.1	29	45.99	69	9.909	109	2.902
-10	303.1	30	44.07	70	9.576	110	2.826
-9	287.1	31	42.23	71	9.253	111	2.747
-8	272.0	32	40.48	72	8.947	112	2.672
-7	257.8	33	38.81	73	8.646	113	2.599
-6	244.4	34	37.23	74	8.362	114	2.528
-5	231.9	35	35.71	75	8.089	115	2.460
-4	220.0	36	34.27	76	7.821	116	2.390
-3	208.7	37	32.89	77	7.569	117	2.322
-2	198.2	38	31.58	78	7.323	118	2.256
-1	188.2	39	30.33	79	7.088	119	2.193
0	178.8	40	29.13	80	6.858	120	2.132
1	169.9	41	27.98	81	6.640	121	2.073
2	161.5	42	26.89	82	6.432	122	2.017
3	153.6	43	25.85	83	6.230	123	1.962
4	146.1	44	24.85	84	6.033	124	1.910
5	139.1	45	23.90	85	5.847	125	1.859
6	132.3	46	22.98	86	5.667		
7	126.0	47	22.10	87	5.492		
8	120.0	48	21.26	88	5.322		
9	114.3	49	20.47	89	5.159		

5.2 Normal Operating Parameters of Refrigerant System

Under the following conditions, the operating parameters given in Tables 5-5.4 and 5-5.5 should be observed:

- The master outdoor unit can detect all the indoor units.
- The number of indoor units displayed on DSP2 is steady and is equal to the actual number of indoor units installed.
- All stop valves are open and all indoor unit EXVs are connected to their unit's PCB.
- If the combination ratio is 100% or less, all the indoor units are currently running and if the combination ratio is more than 100%, indoor units with total capacity equal to the total capacity of the outdoor units are currently running.
- If the outdoor ambient temperature is high, the system is being run in cooling mode with the following settings: temperature 17°C; fan speed high.
- If the outdoor ambient temperature is low, the system is being run in heating mode with the following settings: temperature 30°C; fan speed high.
- The system has been running normally for more than 30 minutes.

Table 5-5.4: Outdoor unit cooling mode operating parameters

Outdoor ambient temperature	°C	< 10	10 to 26	26 to 31	31 to 41	> 41
Average discharge temperature	°C	60-76	62-78	65-82	67-92	69-92
Average discharge superheat	°C	17-30	17-33	17-34	17-36	10-32
Discharge pressure	MPa	2.3-2.8	2.3-2.8	2.4-3.6	2.6-3.8	3.1-4.2
Suction pressure	MPa	0.6-0.7	0.7-0.9	0.8-1.0	1.0-1.2	1.2-1.4
DC inverter compressor current	A	5-12	5-13	5-17	6-17	8-13

Table 5-5.4: Outdoor unit heating mode operating parameters

Outdoor ambient temperature	°C	< -10	-10 to 0	0 to 5	5 to 10	10 to 17	> 17
Average discharge temperature	°C	56-74	57-76	58-78	61-82	63-82	63-82
Average discharge superheat	°C	17-35	17-35	17-35	17-33	14-33	14-33
Discharge pressure	MPa	1.7-2.4	1.8-2.5	1.9-3.0	2.2-3.2	2.3-3.2	2.3-3.2
Suction pressure	MPa	1.4-1.6	1.5-1.7	1.6-2.2	1.8-2.6	1.8-2.6	2.0-2.4
DC inverter compressor current	A	10-15	10-16	5-17	5-17	6-16	6-12



Air Conditioning Systems

Cooling & Heating

TRUST AIR-CONDITIONING EQUIPMENT CO.

Shiraz office: 8 th floor, Alvand Bldg., Dostan St.,
Moaliabad Ave., SHIRAZ, IRAN., Post code: 71877-14446

Tel.: +98-71-36341070

Fax.: +98-71-36341094

Tehran office: No. 19- koohe nour St.- Motahhari St.-

TEHRAN, IRAN., Post code: 15876-73111

Tel.: +98-21-89389

Fax.: +98-21-88541903

Ahwaz office: No. 309- Kaveh St.- AHWAZ, IRAN., Post code: 61939-
47911

Tel.: +98-61-32230647-8

Fax.: +98-61-32230647

E-mail: info@trustacs.com

Web site: <http://www.trustacs.com>

برند برتر در اولین جشنواره بین المللی
برترین نام و نشان های تجاری ایران

